

<b>Field Inspection Manual</b>	<b>Part: 1-Intro</b>	<b>Section: 1</b>	<b>Page: 1 of 1</b>
<b>Non Automatic Weighing Devices</b>	<b>Issued: 2004-03-01</b>	<b>Revision Number: Original</b>	

## **INTRODUCTION**

There should exist a similarity in attitude, procedure and performance by all Measurement Canada personnel and recognized technicians of accredited or registered organizations performing the same general inspections. Uniform application and consistent interpretation of legislation, policies and procedures is key to the effective administration and enforcement of the *Weights and Measure Act*, Regulations and Ministerial Specifications.

The purpose of this Field Inspection Manual (Inspection Procedure Outlines and Standard Test Procedures) is to provide inspectors and other interested parties with a guide to the inspection of non automatic weighing devices and systems. The Inspection Procedure Outlines (IPO) outline the minimum tests which must be performed to ensure that non automatic weighing devices comply with the legislation. The Standard Test Procedures (STP) provide examination criteria for installation and use of devices and describe test procedures.

The use of the IPOs and STPs to evaluate the compliance of a non automatic weighing device or system should be considered the norm rather than the exception. In some circumstances, additional tests may be warranted. In cases such as these, the Regional Specialists should be consulted, and care must be taken to ensure that these tests adhere to the intent of the Act, Regulations and Specifications for Non Automatic Weighing Devices.

Enforcement action shall be initiated when an infraction sufficient enough to warrant non compliance with the legislation is identified. The enforcement strategy shall be in accordance with the Weights and Measures Enforcement Policy for Weighing and Measuring Devices.

Measurement Canada encourages the reference and use of test procedures and test equipment as identified in this manual, but acknowledges that there are alternative test procedures or test equipment that can be used to inspect a weighing or measuring device. Subject to the review and approval of the proposed test procedure or test equipment by Measurement Canada, the alternative methodology will be accepted and documented in the respective Standards Test Procedure (STP) or Inspection Procedure Outline (IPO) on a case-by-case basis.

## **REVISION**

Original document

Field Inspection Manual	Part: 1-Intro	Section: 2	Page: 1 of 1
Non Automatic Weighing Devices	Issued: 2004-04-01	Revision Number: 1	

## INTRODUCTION - SYMBOLS, ACRONYMS AND DEFINITIONS

<b>AZTM</b>	Automatic Zero-Setting Mechanism
<b>d</b>	Actual Scale Interval
<b>DUT</b>	Device Under Test
<b>e</b>	Verification Scale Interval
<b>e<sub>min</sub></b>	Minimum Verification Scale Interval
<b>EMI</b>	Electromagnetic Interference
<b>IPO</b>	Inspection Procedure Outlines
<b>IZSM</b>	Initial Zero-Setting Mechanism
<b>Laboratory</b>	Measurement Canada Laboratory
<b>MC</b>	Measurement Canada
<b>Max</b>	Maximum Capacity
<b>MZSM</b>	Manual Zero-Setting Mechanism
<b>NOA</b>	Notice of Approval
<b>n<sub>max</sub></b>	Maximum Number of Scale Intervals
<b>OIML</b>	Organisation internationale de métrologie légale
<b>PLU Code</b>	Price Look Up Code
<b>POS</b>	Point-of-Sale Weighing System
<b>RFI</b>	Radio Frequency Interference
<b>SAZSM</b>	Semi Automatic Zero-Setting Mechanism
<b>STP</b>	Standard Test Procedures
<b>ZU</b>	Zone of Uncertainty

### **AUTOMATIC WEIGHING DEVICE**

a weighing device that weighs without the intervention of an operator and follows a predetermined program of automatic processes characteristic of the device.

### **NON-AUTOMATIC WEIGHING DEVICE**

a weighing device that weighs discrete loads and that requires an operator's intervention during the weighing process, such as to deposit the load to be measured on the weighing and load-receiving element and to remove it therefrom or to obtain weighing results.

### **REVISION**

Original document

<b>Field Inspection Manual</b>	<b>Part: 1-Intro</b>	<b>Section: 3</b>	<b>Page: 1 of 19</b>
<b>Non Automatic Weighing Devices</b>	<b>Issued: 2011-04-01</b>	<b>Revision Number: 8</b>	

#### INTRODUCTION - REVISIONS TABLE

This document will continue to be periodically reviewed by Measurement Canada to ensure its effectiveness with respect to its objectives.

<b>Date of Revision or Addition</b>	<b>Language</b>	<b>Section</b>	<b>Nature of the Revision or Addition</b>
January 2011	English/French	Part 3, STP-3	Updated marking requirements for Load Cells
January 2010	English/French	Part 2, IPO-5	Change 1 reference from AZSM to AZTM
January 2010	English/French	Part 2, IPO-6	Change 1 reference from AZSM to AZTM
January 2010	English/French	Part 2, IPO-7	Change 1 reference from AZSM to AZTM
January 2010	English/French	Part 2, IPO-8	Change 1 reference from AZSM to AZTM
January 2010	English/French	Part 2, IPO-9	Change 1 reference from AZSM to AZTM
January 2010	English/French	Part 2, IPO-10	Change 1 reference from AZSM to AZTM
January 2010	English/French	Part 2, IPO-11	Change 1 reference from AZSM to AZTM
January 2010	English/French	Part 2, IPO-12	Change 1 reference from AZSM to AZTM
January 2010	English/French	Part 3, STP-08	<p>Add requirements for Automatic Zero Setting Mechanism (AZSM/DMZA).</p> <p>Correct terminology for Automatic Zero Tracking Mechanism (AZTM/AZTM).</p> <p>Reorder definitions &amp; procedures alphabetically.</p> <p>Added OBWS Zero Return requirements.</p>
January 2010	English/French	Part 3, STP-4	Change 1 reference from AZSM to AZTM

<b>Field Inspection Manual</b>	<b>Part: 1-Intro</b>	<b>Section: 3</b>	<b>Page: 2 of 19</b>
<b>Non Automatic Weighing Devices</b>	<b>Issued: 2011-04-01</b>	<b>Revision Number: 8</b>	

**INTRODUCTION - REVISIONS TABLE**

<b>Date of Revision or Addition</b>	<b>Language</b>	<b>Section</b>	<b>Nature of the Revision or Addition</b>
January 2010	English/French	Part 3, STP-10	Change 1 reference from AZSM to AZTM
January 2010	English/French	Part 3, STP-14	Change 1 reference from AZSM to AZTM
January 2010	English/French	Part 3, STP-26	Change 1 reference from AZSM to AZTM
January 2010	English/French	Part 3, STP-28	Change 1 reference from AZSM to AZTM
January 2010	English/French	Part 3, STP-3	Change 1 reference from AZSM to AZTM
February 2009	English/French	Part 3, STP-2	Added Max/e <sub>min</sub> table for pre-NAWDS devices.
February 2009	English/French	Part 3, STP-7	Added section for Winter Installation (approaches / foundation).
February 2009	English/French	Part 3, STP-9	Remove requirement for LRE to be empty before allowing MWE.
October 2008	English/French	Part 3, STP-15	Harmonize load requirements and patterns for scales with not more than 4 points of support.  Remove note from railroad scale test procedure.  Update cart procedures to allow movement on/off load receiving element while loaded.
October 2008	English/French	Part 3, STP-30	New Procedure
January 2008	English/French	Part 2, IPO-2	Added POS definition.
July 2007	English/French	Part 3, STP-29	New Procedure

<b>Field Inspection Manual</b>	<b>Part: 1-Intro</b>	<b>Section: 3</b>	<b>Page: 3 of 19</b>
<b>Non Automatic Weighing Devices</b>	<b>Issued: 2011-04-01</b>	<b>Revision Number: 8</b>	

**INTRODUCTION - REVISIONS TABLE**

<b>Date of Revision or Addition</b>	<b>Language</b>	<b>Section</b>	<b>Nature of the Revision or Addition</b>
June 2007	English/French	Part 3, STP-10	<p>Clarify requirement for marking the device when in sleep mode. This change correct a contradiction between the Approval Evaluation Manual and this manual.</p> <p>Correct references to Specifications Relating to Non-automatic Weighing Devices (1998).</p>

Field Inspection Manual	Part: 1-Intro	Section: 3	Page: 4 of 19
Non Automatic Weighing Devices	Issued: 2011-04-01	Revision Number: 8	

INTRODUCTION - REVISIONS TABLE

Date of Revision or Addition	Language	Section	Nature of the Revision or Addition
May 2007	English	Part 3, STP-7	<p>Added requirements for Temporary Installation of Portable Vehicle Scales.</p> <p>Clarified grout/shim requirements for vehicle scale installations.</p> <p>Clarified approach requirements for vehicle scale installations.</p> <p>Added confined space entry criteria for entering scale pits.</p> <p>Removal of obsolete terminology ('contractor scale').</p> <p>Clarified wording &amp; intent in several sections.</p> <p>Added secondary indicator criteria for POS as per GSC 2006-04(f).</p> <p>Expanded requirement for access to scale and necessary rigging for application of standards.</p> <p>Removal of 'to the public' from direct sales references.</p> <p>Added securing of counter scales when appropriate.</p> <p>Added weight receiving requirements for tank/hopper scales.</p> <p>Correct references to <i>Specifications Relating to Non-automatic Weighing Devices (1998)</i>.</p>

Field Inspection Manual	Part: 1-Intro	Section: 3	Page: 5 of 19
Non Automatic Weighing Devices	Issued: 2011-04-01	Revision Number: 8	

INTRODUCTION - REVISIONS TABLE

Date of Revision or Addition	Language	Section	Nature of the Revision or Addition
Mar 2007	English/French	Part 3, STP-8	<p>Add 10 second delay on power cycle to IZSM procedure</p> <p>Clarify Interpretation section for AZSM procedure</p> <p>Delete "to the Public" form Direct Sales references.</p> <p>Correct grammatical and general formatting issues.</p> <p>Correct references to Specifications Relating to Nonautomatic Weighing Devices (1998).</p>
July 2006	English/French	Part 2, IPO-2a	Added POS definition
July 2006	English/French	Part 2, IPO-10a	Remove reference to static weighing
July 2006	English/French	Part 3, STP-6	<p>Remove POS definition from this section. See IPO 2.2 (POS).</p> <p>Add <i>Dimensional Weight at Retail</i> requirements.</p> <p>Correct references to Specifications Relating to Non-automatic Weighing Devices (1998).</p>

<b>Field Inspection Manual</b>	<b>Part: 1-Intro</b>	<b>Section: 3</b>	<b>Page: 6 of 19</b>
<b>Non Automatic Weighing Devices</b>	<b>Issued: 2011-04-01</b>	<b>Revision Number: 8</b>	

**INTRODUCTION - REVISIONS TABLE**

<b>Date of Revision or Addition</b>	<b>Language</b>	<b>Section</b>	<b>Nature of the Revision or Addition</b>
July 2006	English/French	Part 3, STP-11a	<p>Removed all remaining references to Laboratory Evaluation Manual.</p> <p>11.1.5 added prefer +9e for all scales, although +5% is still allowable.</p> <p>(9e will always be less than 5% Max).</p> <p>Change reference from "Direct Sales to the Public" to "Direct Sales".</p> <p>Change all remaining fractions to decimals to maintain consistency throughout FIM.</p> <p>Rename section 11.9 to Customer Display.</p> <p>Correct reference to Specifications Relating to Non-automatic Weighing Devices (1998).</p> <p>Remove definition of POS from this STP. See IPO 2.20 (POS)</p>
May 2006	English/French	Part 2, IPO-3a	<p>Add STP-29 reference for Trade Weights.</p> <p>Remove trade weight examination &amp; calibration procedures from IPO</p>
May 2006	English/French	Part 2, IPO-5	<p>Add STP-29 reference for Trade Weights.</p> <p>Remove trade weight examination &amp; calibration procedures from IPO.</p>

<b>Field Inspection Manual</b>	<b>Part: 1-Intro</b>	<b>Section: 3</b>	<b>Page: 7 of 19</b>
<b>Non Automatic Weighing Devices</b>	<b>Issued: 2011-04-01</b>	<b>Revision Number: 8</b>	

**INTRODUCTION - REVISIONS TABLE**

<b>Date of Revision or Addition</b>	<b>Language</b>	<b>Section</b>	<b>Nature of the Revision or Addition</b>
July 2006	English/French	Part 3, STP-6	<p>Remove POS definition from this section. See IPO 2.2 (POS).</p> <p>Add <i>Dimensional Weight at Retail</i> requirements.</p> <p>Correct references to <i>Specifications Relating to Non-automatic Weighing Devices (1998)</i>.</p>

<b>Field Inspection Manual</b>	<b>Part: 1-Intro</b>	<b>Section: 3</b>	<b>Page: 8 of 19</b>
<b>Non Automatic Weighing Devices</b>	<b>Issued: 2011-04-01</b>	<b>Revision Number: 8</b>	

**INTRODUCTION - REVISIONS TABLE**

<b>Date of Revision or Addition</b>	<b>Language</b>	<b>Section</b>	<b>Nature of the Revision or Addition</b>
May 2006	English/French	Part 3, STP-7	<p>Added requirements for Temporary Installation of Portable Vehicle Scales.</p> <p>Clarified grout/shim requirements for vehicle scale installations.</p> <p>Clarified approach requirements for vehicle scale installations.</p> <p>Added confined space entry criteria for entering scale pits.</p> <p>Removal of obsolete terminology ('contractor scale').</p> <p>Clarified wording &amp; intent in several sections.</p> <p>Added secondary indicator criteria for POS as per GSC 2006-04(f).</p> <p>Expanded requirement for access to scale and necessary rigging for application of standards.</p> <p>Removal of 'to the public' from direct sales references.</p> <p>Added securing of counter scales when appropriate.</p> <p>Added weight receiving requirements for tank/hopper scales.</p> <p>Correct references to Specifications Relating to Non-automatic Weighing Devices (1998).</p>
May 2006	English/French	Part 3, STP-ToC	Added STP-29 Calibration of Counterpoise and Other Trade Weights

<b>Field Inspection Manual</b>	<b>Part: 1-Intro</b>	<b>Section: 3</b>	<b>Page: 9 of 19</b>
<b>Non Automatic Weighing Devices</b>	<b>Issued: 2011-04-01</b>	<b>Revision Number: 8</b>	

**INTRODUCTION - REVISIONS TABLE**

<b>Date of Revision or Addition</b>	<b>Language</b>	<b>Section</b>	<b>Nature of the Revision or Addition</b>
May 2006	English/French	Part 3, STP-2	<p>Delete "to the Public" form Direct Sales references.</p> <p>Add Counting Scale requirements for approval and inspection.</p> <p>Correct several inconsistencies and general formatting issues.</p> <p>Correct references to Specifications Relating to Non-automatic Weighing Devices (1998).</p>

Field Inspection Manual	Part: 1-Intro	Section: 3	Page: 10 of 19
Non Automatic Weighing Devices	Issued: 2011-04-01	Revision Number: 8	

INTRODUCTION - REVISIONS TABLE

Date of Revision or Addition	Language	Section	Nature of the Revision or Addition
May 2006	English/French	Part 3, STP-3	<p>Correct references to <b>e</b> and <b>d</b> as necessary.</p> <p>Correct reference to <i>Terms and Conditions for Metrological Software</i> in section 3.3.1.</p> <p>Correct references to Approval Evaluation Manual - Non Automatic Weighing Devices.</p> <p>Remove reference "to the Public" from Direct Sales markings section 3.7.</p> <p>Clarify multi-deck marking requirements in section 3.8. Marking height is no longer a recommendation.</p> <p>Correct miscellaneous spelling errors and ensure consistent formatting.</p> <p>Clarify same units marking requirements for <b>Max</b> and <b>e/d</b>.</p> <p>Added marking requirement for Precious Metals &amp; Precious Stones devices.</p> <p>Added auxiliary housing requirements.</p> <p>Correct references to Specifications Relating to Non-automatic Weighing Devices (1998).</p> <p>Specify the minimum height of characters used for marking.</p>

<b>Field Inspection Manual</b>	<b>Part: 1-Intro</b>	<b>Section: 3</b>	<b>Page: 11 of 19</b>
<b>Non Automatic Weighing Devices</b>	<b>Issued: 2011-04-01</b>	<b>Revision Number: 8</b>	

**INTRODUCTION - REVISIONS TABLE**

<b>Date of Revision or Addition</b>	<b>Language</b>	<b>Section</b>	<b>Nature of the Revision or Addition</b>
May 2006	English/French	Part 3, STP-4	<p>Change references from 'Draft Specifications' to 'Terms and Conditions' as appropriate.</p> <p>Change reference to Approval Evaluation Manual - Non Automatic Weighing Devices.</p> <p>Correct references to Specifications Relating to Non automatic Weighing Devices (1998).</p>

<b>Field Inspection Manual</b>	<b>Part: 1-Intro</b>	<b>Section: 3</b>	<b>Page: 12 of 19</b>
<b>Non Automatic Weighing Devices</b>	<b>Issued: 2011-04-01</b>	<b>Revision Number: 8</b>	

**INTRODUCTION - REVISIONS TABLE**

<b>Date of Revision or Addition</b>	<b>Language</b>	<b>Section</b>	<b>Nature of the Revision or Addition</b>
May 2006	English/French	Part 3, STP-7	<p>Added requirements for Temporary Installation of Portable Vehicle Scales.</p> <p>Clarified grout/shim requirements for vehicle scale installations.</p> <p>Clarified approach requirements for vehicle scale installations.</p> <p>Added confined space entry criteria for entering scale pits.</p> <p>Removal of obsolete terminology ('contractor scale').</p> <p>Clarified wording &amp; intent in several sections.</p> <p>Added secondary indicator criteria for POS as per GSC 2006-04(f).</p> <p>Expanded requirement for access to scale and necessary rigging for application of standards.</p> <p>Removal of 'to the public' from direct sales references.</p> <p>Added securing of counter scales when appropriate.</p> <p>Added weight receiving requirements for tank/hopper scales.</p> <p>Correct references to Specifications Relating to Non-automatic Weighing Devices (1998).</p>

<b>Field Inspection Manual</b>	<b>Part: 1-Intro</b>	<b>Section: 3</b>	<b>Page: 13 of 19</b>
<b>Non Automatic Weighing Devices</b>	<b>Issued: 2011-04-01</b>	<b>Revision Number: 8</b>	

**INTRODUCTION - REVISIONS TABLE**

<b>Date of Revision or Addition</b>	<b>Language</b>	<b>Section</b>	<b>Nature of the Revision or Addition</b>
May 2006	English/French	Part 3, STP-9a	<p>Clarified manual weight entry requirements.</p> <p>Exempt Not For Direct Sales devices from complying with manual weight entry requirements.</p> <p>Allow manual weight entries on vehicle scales even if the scale is not at gross load zero.</p> <p>Correct references to Specifications Relating to Non-automatic Weighing Devices (1998).</p> <p>Indicate that manual gross value and manual tare value are prohibited with on-board weighing systems.</p>

<b>Field Inspection Manual</b>	<b>Part: 1-Intro</b>	<b>Section: 3</b>	<b>Page: 14 of 19</b>
<b>Non Automatic Weighing Devices</b>	<b>Issued: 2011-04-01</b>	<b>Revision Number: 8</b>	

**INTRODUCTION - REVISIONS TABLE**

<b>Date of Revision or Addition</b>	<b>Language</b>	<b>Section</b>	<b>Nature of the Revision or Addition</b>
May 2006	English/French	Part 3, STP-15a	<p>Added motorized cart requirements and load restrictions.</p> <p>Added railroad scale test procedures.</p> <p>Added minimum recommended test loads for vehicle scale eccentricity testing.</p> <p>Added maximum recommended length of test load for vehicle scale eccentricity testing.</p> <p>Change vehicle scale graphic from 4 section to 3 section to facilitate test load length depiction.</p> <p>Added rationale for applying test load to center or number 1 position on platform scales.</p> <p>Bulletin reorganized to group common inspection types.</p> <p>Correct references to Specifications Relating to Non-automatic Weighing Devices (1998).</p>

Field Inspection Manual	Part: 1-Intro	Section: 3	Page: 15 of 19
Non Automatic Weighing Devices	Issued: 2011-04-01	Revision Number: 8	

INTRODUCTION - REVISIONS TABLE

Date of Revision or Addition	Language	Section	Nature of the Revision or Addition
May 2006	English/French	Part 3, STP-17a	<p>Remove 'verification scale' from agreement sections as auxiliary equipment does not have verification scale intervals.</p> <p>Added Smart Scoreboard section.</p> <p>Added and clarified POS agreement and use of secondary indicators (PODs).</p> <p>Moved Not for Direct Sale applications to its own separate section (previously contained in POS systems).</p> <p>Minor changes to terminology in Weight Classifier section.</p> <p>Correct references to Specifications Relating to Non-automatic Weighing Devices (1998).</p>
May 2006	English/French	Part 3, STP-18	<p>Reference to +9e being preferred blanking point for all Non-Automatic Weighing Devices (OIML R76 4.2.3).</p> <p>Clarify reason for some unacceptable display options.</p> <p>Change reference from 'scale' to 'non automatic weighing device'.</p> <p>Change various references to <b>d</b> and/or scale division to verification scale interval or <b>e</b>.</p> <p>Correct references to Specifications Relating to Non-automatic Weighing Devices (1998).</p>

Field Inspection Manual	Part: 1-Intro	Section: 3	Page: 16 of 19
Non Automatic Weighing Devices	Issued: 2011-04-01	Revision Number: 8	

INTRODUCTION - REVISIONS TABLE

Date of Revision or Addition	Language	Section	Nature of the Revision or Addition
May 2006	English/French	Part 3, STP-25a	<p>Added clarification to <i>Interpretation of Results</i> when preventing indication is not feasible, a warning message may suffice.</p> <p>Correct reference to Specifications Relating to Non-automatic Weighing Devices (1998).</p>
May 2006	English/French	Part 3, STP-26	<p>Clarified and added examples of the possible configurations.</p> <p>Added STARS/PICASSO coding information.</p> <p>Ensure consistent terminology for Load Receiving and Indicating Elements.</p> <p>Added inspection test criteria.</p> <p>Correct references to Specifications Relating to Non-automatic Weighing Devices (1998).</p>

Field Inspection Manual	Part: 1-Intro	Section: 3	Page: 17 of 19
Non Automatic Weighing Devices	Issued: 2011-04-01	Revision Number: 8	

INTRODUCTION - REVISIONS TABLE

Date of Revision or Addition	Language	Section	Nature of the Revision or Addition
May 2006	English/French	Part 3, STP-28	<p>Added section 28.1.4, Maximum Capacity of Partial Weighing Ranges.</p> <p>(OIML R76 3.3.3) Recommendation Only.</p> <p>Corrected <b>d</b> must equal <b>e</b> references.</p> <p>Added table data for calculating <b>n</b> in section 28.1.3.</p> <p>Corrected general formatting issues.</p> <p>Correct references to Specifications Relating to Non-automatic Weighing Devices (1998).</p>
May 2006	English/French	Part 3, STP-29	New Procedure
November 2005	English/French	Part 3, STP-26	<p>Clarified and added examples of the possible configurations.</p> <p>Added STARS/PICASSO coding information.</p> <p>Ensure consistent terminology for <i>Load Receiving</i> and <i>Indicating Elements</i>.</p> <p>Added inspection test criteria.</p> <p>Correct references to <i>Specifications Relating to Non-automatic Weighing Devices (1998)</i>.</p>
September 2005	English/French	Part 4, Appendix-C	New Appendix - Suitable Test Standards
April 2005	English/French	Part 2, IPO-03	Appendix -C to address suitable standards

<b>Field Inspection Manual</b>	<b>Part: 1-Intro</b>	<b>Section: 3</b>	<b>Page: 18 of 19</b>
<b>Non Automatic Weighing Devices</b>	<b>Issued: 2011-04-01</b>	<b>Revision Number: 8</b>	

**INTRODUCTION - REVISIONS TABLE**

<b>Date of Revision or Addition</b>	<b>Language</b>	<b>Section</b>	<b>Nature of the Revision or Addition</b>
April 2005	English/French	Part 3, STP-11	Section 11.8 reference STP 28 of this manual
April 2005	English/French	Part 3, STP-17	Elimination of the 10 x 1d load registration agreement test
April 2005	English/French	Part 3, STP-15	modified & simplified forklift / hand truck loading requirements
April 2005	English/French	Part 3, STP-ToC	Added STP-28 Multi-Interval and Multiple Range Devices.  Added Appendix C - Standards Accuracy Class Non-Automatic Weighing Devices
April 2005	English/French	Part 3, STP-11	Section 11.8 reference STP 28 of this manual
April 2005	English/French	Part 3, STP-15	Modified & simplified forklift / hand truck loading requirements.
April 2005	English/French	Part 3, STP-17	Elimination of the 10 x 1d load registration agreement test.
November 2004	English/French	Part 2, IPO-11	Addition of device types 9.30 & 9.40
November 2004	English/French	Part 3, STP-07	Winter installations
November 2004	English/French	Part 3, STP-15	Added eccentricity tests.  Minor wording changes.
November 2004	English/French	Part 3, STP- 25	Wording section 25.4

<b>Field Inspection Manual</b>	<b>Part: 1-Intro</b>	<b>Section: 3</b>	<b>Page: 19 of 19</b>
<b>Non Automatic Weighing Devices</b>	<b>Issued: 2011-04-01</b>	<b>Revision Number: 8</b>	

**INTRODUCTION - REVISIONS TABLE**

<b>Date of Revision or Addition</b>	<b>Language</b>	<b>Section</b>	<b>Nature of the Revision or Addition</b>
November 2004	English/French	Part 3, STP-15	<p>Change reference from “load cell” to “support point” to cover all scale types.</p> <p>Added eccentricity drawing for Forklift, single support.</p> <p>Corrected number of support points reference in platform scales (#4).</p> <p>Added procedure for platform scales with more than four support points.</p> <p>Added procedure for “side by side” deck vehicle scales.</p>
November 2004	English/French	Part 3, STP-25	Modified section 25.4 - added <i>upon demand</i> to requirement.

**REVISION**  
Revision 8

<b>Field Inspection Manual</b>	Part: <b>2-IPO</b>	Section: <b>1</b>	Page: <b>1 of 2</b>
<b>Non Automatic Weighing Devices</b>	Issued: <b>2004-03-01</b>	Revision Number: <b>Original</b>	

**TYPE 2.10, 2.30 - RETAIL COMPUTING SCALES**

**APPLICATION**

Electronic or mechanical computing counter scales, including pre-packing scales and weight classifiers

**EQUIPMENT**

Inspector's weight kit.

**USE**

Device is approved for trade use ..... NoA, Act Section 8  
 Device is suitable for the actual use ..... STP-1  
 Device has been initially inspected (if applicable) and bears the initial verification marks ..... R.29  
 Device is sealed ..... NoA, STP-4

**VISUAL EXAMINATION - INSTALLATION AND LOCATION ..... STP-7**

Device is installed in accordance with restrictions and conditions listed in the notice of approval and in accordance with manufacturer's instructions  
 Device is adequately supported  
 Device indicating and load receiving elements are positioned for customer's view (if applicable)  
 Clearance around load receptor  
 Device is properly levelled  
 Device is adequately protected

**VISUAL EXAMINATION - MARKING ..... STP-3**

Device is marked with the required information  
 Marking is located as required  
 Marking is permanent (if applicable)  
 Marking plate is permanently attached to the device

**VISUAL EXAMINATION - INDICATING ELEMENT ..... STP-5**

(Electronic)  
 Display Test (Segment)  
 Indicated and recorded values are adequately defined  
 Defining words and symbols for annunciators (Tare Entered, Gross and Net Weight, Center-of-Zero) are readable

(Mechanical)  
 Scale marks, pointers and poise are in good condition  
 Defining words and symbols are readable  
 Zero setting material is enclosed and secured  
 Balancing ball is in good condition and secured in place

<b>Field Inspection Manual</b>	Part: <b>2-IPO</b>	Section: <b>1</b>	Page: <b>2 of 2</b>
<b>Non Automatic Weighing Devices</b>	Issued: <b>2004-03-01</b>	Revision Number: <b>Original</b>	

**TYPE 2.10, 2.30 - RETAIL COMPUTING SCALES**

**VISUAL EXAMINATION - RECORDING ELEMENT (PRINTER) . . . . . STP-6**

Device prints the required values  
Printed values are adequately defined

**DEVICE CONFIGURATION (ELECTRONIC)**

Device configured as prescribed by the NOA . . . . . STP-2

Zero Setting Mechanism Range ( 4% of Max or more) . . . . . STP-8

\*Initial Zero Setting Mechanism Range (20% of Max or more)

AZTM Maximum Range (0.6 e)

\*Manual Entries of Gross Weights . . . . . STP-9

\*Sleep Mode Test . . . . . STP-10

Tare (Platter, Keyboard, and Pre-programmed Tare Entry) . . . . . STP-11

Free Floating Weight Signal . . . . . STP-12

**PERFORMANCE**

Load Discrimination Test (Near Zero) . . . . . STP-14

Increasing Test . . . . . STP-13

Eccentricity Test . . . . . STP-15

Load Discrimination (Max) . . . . . STP-14

Agreement of Registration . . . . . STP-17

Display Blanking Tests (Zero, Tare) . . . . . STP-18

Decreasing and Return-to-Zero Test . . . . . STP-13

Repeatability Test . . . . . STP-16

Motion Detection Test . . . . . STP-19

Accuracy of Price Computation . . . . . STP-20

Mathematical Concordance of Tare, Net and Gross Weight . . . . . STP-21

Disturbance Test (Electromagnetic Interference and Radio Frequency Interference, Vibrations) . . STP-23

**WEIGHT CLASSIFIERS**

For the load discrimination test and agreement of registration test, see special instructions in  
. . . . . STP-14 and STP-17

**NOTE:** Tests marked with the star \* are performed at the initial inspection only.

**REVISION**

Original document

<b>Field Inspection Manual</b>	Part: <b>2-IPO</b>	Section: <b>2</b>	Page: <b>1 of 2</b>
<b>Non Automatic Weighing Devices</b>	Issued: <b>2008-01-01</b>	Revision Number: <b>1</b>	

**TYPE 2.20 POINT OF SALE (POS) WEIGHING SYSTEMS**

**APPLICATION**

Electronic POS systems used in conjunction with cash registers or computers. A POS system is defined as a weighing element or non-computing scale interfaced with an electronic cash register (ECR) or computer and intended for use in direct sales of individually measured commodities to a consumer. The ECR or computer obtains the gross weight provided by the scale, may calculate a net weight based upon appropriate tare values, and calculates a total price proportional to the weight of commodity being measured. The price per unit for the commodity may be manually entered or may be derived from a Price Lookup Code (PLU). Stand alone price computing scales, weight classifiers and other scales used in weight classification applications are not to be considered POS systems.

**EQUIPMENT**

Inspector's weight kit.

**USE**

Device is approved for trade use . . . . . NoA, Act Section 8  
 Device is suitable for the actual use . . . . . STP-1  
 Device has been initially inspected (if applicable) and bears the initial verification marks . . . . . R.29  
 Device is sealed . . . . . NoA, STP-4

**VISUAL EXAMINATION - INSTALLATION AND LOCATION . . . . . STP-7**

Device is installed in accordance with restrictions and conditions listed in the notice of approval and in accordance with manufacturer's instructions  
 Device is adequately supported  
 Device indicating and load receiving elements are positioned for customer's view (if applicable)  
 Clearance around load receptor  
 Device is properly levelled and secured as appropriate  
 Device is adequately protected

**VISUAL EXAMINATION - MARKING . . . . . STP-3**

Device is marked with the required information  
 Marking is located as required  
 Marking is permanent (if applicable)  
 Marking plate is permanently attached to the device

**VISUAL EXAMINATION - INDICATING ELEMENT (ELECTRONIC) . . . . . STP-5**

Display Test (Segment)  
 Indicated and recorded values are adequately defined  
 Defining words and symbols for annunciators (Tare Entered, Gross and Net Weight, Center-of-Zero) are readable

<b>Field Inspection Manual</b>	Part: <b>2-IPO</b>	Section: <b>2</b>	Page: <b>2 of 2</b>
<b>Non Automatic Weighing Devices</b>	Issued: <b>2008-01-01</b>	Revision Number: <b>1</b>	

**TYPE 2.20 POINT OF SALE (POS) WEIGHING SYSTEMS**

**VISUAL EXAMINATION (RECORDING ELEMENT) . . . . . STP-6**

Recording element (Cash Register Tape) in compliance  
Cash register tape contain all required information  
Printed values are adequately defined

**DEVICE CONFIGURATION (ELECTRONIC)**

Device configured as prescribed by the NOA . . . . . STP-2

Zero Setting Mechanism Range ( 4% of Max or more) . . . . . STP-8

\*Initial Zero Setting Mechanism Range (20% of Max or more)  
AZSM Maximum Range (0.6 e)

\*Manual Entries of Gross Weights . . . . . STP-9

\*Sleep Mode Test . . . . . STP-10

Tare (Platter, Keyboard, and Pre-programmed Tare Entry) . . . . . STP-11

Free Floating Weight Signal . . . . . STP-12

**PERFORMANCE**

Load Discrimination Test (Near Zero) . . . . . STP-14

Increasing Test . . . . . STP-13

Eccentricity Test . . . . . STP-15

Load Discrimination (Max) . . . . . STP-14

Agreement of Registration . . . . . STP-17

Display Blanking Tests (Zero, Tare) . . . . . STP-18

Decreasing and Return-to-Zero Test . . . . . STP-13

Repeatability Test . . . . . STP-16

Motion Detection Test . . . . . STP-19

Accuracy of Price Computation . . . . . STP-20

Mathematical Concordance of Tare, Net and Gross Weight . . . . . STP-21

Disturbance Test (Electromagnetic Interference and Radio Frequency Interference, Vibrations) . . STP-23

**Note:** Tests marked with the star \* are performed at the initial inspection only.

**REVISION**

Rev 1.

- added POS definition.

<b>Field Inspection Manual</b>	Part: <b>2-IPO</b>	Section: <b>3</b>	Page: <b>1 of 2</b>
<b>Non Automatic Weighing Devices</b>	Issued: <b>2008-01-01</b>	Revision Number: <b>2</b>	

**TYPE 3.10      EQUAL ARM SCALES**

**APPLICATION**

Equal arm pan-over-beam and beam-over-pan scales used to weigh commodities in trade including precious metals.

**EQUIPMENT**

Inspector's weight kit.

**NOTE:** Inspection of precious metal scale (Class II or Class I) requires the use of special accuracy test weights.

**USE**

Device is approved for trade use ..... NoA, Act Section 8  
 Device is suitable for the actual use ..... STP-1  
 Device has been initially inspected (if applicable) and bears the initial verification marks ..... R.29  
 Total capacity of weights does not exceed the scale capacity

**VISUAL EXAMINATION - INSTALLATION AND LOCATION ..... STP-7**

Device is installed in accordance with restrictions and conditions listed in the notice of approval and in accordance with manufacturer's instructions  
 Device is adequately supported  
 Device indicating and load receiving elements are positioned for customer's view (if applicable)  
 Clearance around load receptor  
 Device is properly leveled  
 Device is adequately protected

**VISUAL EXAMINATION - MARKING ..... STP-3**

Device is marked with the required information  
 Marking is located as required  
 Marking is permanent (if applicable)  
 Marking plate is permanently attached to the device

**VISUAL EXAMINATION - INDICATING ELEMENT ..... STP-5**

Weight values are adequately defined  
 Scale marks and pointers are in proper condition  
 Material for adjusting zero is enclosed and secured  
 Balancing ball is in good condition and secured in place

<b>Field Inspection Manual</b>	Part: <b>2-IPO</b>	Section: <b>3</b>	Page: <b>2 of 2</b>
<b>Non Automatic Weighing Devices</b>	Issued: <b>2008-01-01</b>	Revision Number: <b>2</b>	

**TYPE 3.10      EQUAL ARM SCALES**

**PERFORMANCE**

Load Discrimination Test (No Load) ..... STP-14  
Increasing Test ..... STP-13  
Eccentricity Test (not required on beam-over-pan scales) ..... STP-15  
Load Discrimination (Max) ..... STP-14  
Decreasing and Return-to-Zero Test ..... STP-13  
Repeatability Test ..... STP-16

**TRADE WEIGHTS**

Calibration of Counterpoise & Other Trade Weights ..... STP-29

**REVISION**

- Rev 2.  
- add STP-29 reference for Trade Weights  
- remove trade weight examination & calibration procedures from IPO
- Rev. 1  
- Reference to Appendix C for appropriate standards

<b>Field Inspection Manual</b>	Part: <b>2-IPO</b>	Section: <b>4</b>	Page: <b>1 of 2</b>
<b>Non Automatic Weighing Devices</b>	Issued: <b>2004-03-01</b>	Revision Number: <b>Original</b>	

**TYPE 3.10      STEEL YARD SCALES**

**APPLICATION**

Mechanical steel yard type scales including double beam hanging scales

**EQUIPMENT**

Inspector's weight kit, local standards in sufficient number and capacity, and weight suspension equipment.

**USE**

- Device is approved for trade use . . . . . NoA, Act Section 8
- Device is suitable for the actual use . . . . . STP-1
- Device has been initially inspected (if applicable) and bears the initial verification marks . . . . . R.29

**VISUAL EXAMINATION - INSTALLATION AND LOCATION . . . . . STP-7**

- Device is installed in accordance with restrictions and conditions listed in the notice of approval and in accordance with manufacturer's instructions
- Device is adequately supported
- Device indicating and load receiving elements are positioned for customer's view (if applicable)
- Clearance around load receptor
- Device is properly levelled
- Device is adequately protected

**VISUAL EXAMINATION - MARKING . . . . . STP-3**

- Device is marked with the required information
- Marking is located as required
- Marking is permanent (if applicable)
- Marking plate is permanently attached to the device

**VISUAL EXAMINATION - BEAM, POISE, AND ZERO SETTING MECHANISM . . . . . STP-5**

- Weight values are adequately defined
- Scale marks and numbering are clear and readable
- Poise is clean; no part has been lost;
- Poise adjusting material is enclosed and held firmly in position
- Poise indicating component is in good condition and allows for accurate readings
- Material for setting zero is enclosed and secured
- Balance ball assembly is held firmly in position

**PERFORMANCE**

- Load Discrimination Test (No Load) . . . . . STP-14
- Increasing Test . . . . . STP-13
- Eccentricity Test (not required on beam-over-pan scales) . . . . . STP-15
- Load Discrimination (Max) . . . . . STP-14
- Decreasing and Return-to-Zero Test . . . . . STP-13

<b>Field Inspection Manual</b>	Part: <b>2-IPO</b>	Section: <b>4</b>	Page: <b>2 of 2</b>
<b>Non Automatic Weighing Devices</b>	Issued: <b>2004-03-01</b>	Revision Number: <b>Original</b>	

**TYPE 3.10      STEEL YARD SCALES**

Repeatability Test ..... STP-16

**REVISION**

Original document

<b>Field Inspection Manual</b>	Part: <b>2-IPO</b>	Section: <b>5</b>	Page: <b>1 of 2</b>
<b>Non Automatic Weighing Devices</b>	Issued: <b>2008-01-01</b>	Revision Number: <b>1</b>	

**TYPE 3.10      PLATFORM SCALES**

**APPLICATION**

Electronic or mechanical bench, platform, floor or dormant scales

**EQUIPMENT**

Inspector's weight kit, local standards of sufficient number and capacity, and material for strain or substitution test (if necessary).

**USE**

- Device is approved for trade use ..... NoA, Act Section 8
- Device is suitable for the actual use ..... STP-1
- Device has been initially inspected (if applicable) and bears the initial verification marks ..... R.29
- Device is sealed ..... NoA, STP-4

**VISUAL EXAMINATION - INSTALLATION AND LOCATION ..... STP-7**

- Device is installed in accordance with restrictions and conditions listed in the notice of approval and in accordance with manufacturer's instructions
- Device is adequately supported
- Device indicating and load receiving elements are positioned for customer's view (if applicable)
- Load receiving element can be observed from indicator's reading position
- Clearance around load receptor
- Device is properly levelled
- Device is adequately protected

**VISUAL EXAMINATION - MARKING ..... STP-3**

- Device is marked with the required information
- Marking is located as required
- Marking is permanent (if applicable)
- Marking plate is permanently attached to the device

**VISUAL EXAMINATION - INDICATING ELEMENT ..... STP-5**

- (Electronic)
- Display Test (Segment)
- Indicated and recorded values are adequately defined
- Defining words and symbols for annunciators (Tare Entered, Gross and Net Weight, Center-of-Zero) are readable

- (Mechanical)
- Scale marks, pointers and poise are in good condition
- Defining words and symbols are readable
- Zero setting material is enclosed and secured
- Balancing ball is in good condition and secured in place
- Poise adjusting material is enclosed and held firmly in position

<b>Field Inspection Manual</b>	Part: <b>2-IPO</b>	Section: <b>5</b>	Page: <b>2 of 2</b>
<b>Non Automatic Weighing Devices</b>	Issued: <b>2008-01-01</b>	Revision Number: <b>1</b>	

**TYPE 3.10      PLATFORM SCALES**

**VISUAL EXAMINATION - RECORDING ELEMENT (PRINTER) . . . . . STP-6**

Device prints the required values  
Printed values are adequately defined

**DEVICE CONFIGURATION (ELECTRONIC)**

Device configured as prescribed by the NOA . . . . . STP-2

Zero Setting Mechanism Range ( 4% of Max or more) . . . . . STP-8

\*Initial Zero Setting Mechanism Range (20% of Max or more)

AZTM Maximum Range (0.6 e)

\*Manual Entries of Gross Weights . . . . . STP-9

\*Sleep Mode Test . . . . . STP-10

Tare (Platter, Keyboard, and Pre-programmed Tare Entry) . . . . . STP-11

Free Floating Weight Signal . . . . . STP-12

**PERFORMANCE**

Load Discrimination Test (Near Zero) . . . . . STP-14

Increasing Test . . . . . STP-13

Eccentricity Test . . . . . STP-15

Load Discrimination (Max) . . . . . STP-14

Agreement of Registration . . . . . STP-17

Display Blanking Tests (Zero, Tare) . . . . . STP-18

Decreasing and Return-to-Zero Test . . . . . STP-13

Repeatability Test . . . . . STP-16

Motion Detection Test . . . . . STP-19

Accuracy of Price Computation . . . . . STP-20

Mathematical Concordance of Tare, Net and Gross Weight . . . . . STP-21

\*Off-Level Test (if applicable) . . . . . STP-22

Disturbance Test (Electromagnetic Interference and Radio Frequency Interference, Vibrations) . . STP-23

**MULTI-DECK WEIGHING SYSTEMS . . . . . STP-26**

**BEAM SCALES**

Calibration of Counterpoise & Other Trade Weights . . . . . STP-29

**Note:** Tests marked with the star \* are performed at the initial inspection only.

**REVISION**

Rev 1.

- add STP-29 reference for Trade Weights.
- remove trade weight examination & calibration procedures from IPO

<b>Field Inspection Manual</b>	Part: <b>2 - IPO</b>	Section: <b>6</b>	Page: <b>1 of 2</b>
<b>Non Automatic Weighing Devices</b>	Issued: <b>2004-03-01</b>	Revision Number: <b>Original</b>	

**TYPE 3.10 SINGLE-POINT SUSPENDED SCALES**

**APPLICATION**

Electronic or mechanical hanging scales with capacities up to and including 1000 kg (2000 pounds)

**EQUIPMENT**

Inspector's weight kit, local standards in sufficient number and capacity, and material for strain test (if necessary).

**USE**

Device is approved for trade use . . . . . NoA, Act Section 8  
 Device is suitable for the actual use . . . . . STP-1  
 Device has been initially inspected (if applicable) and bears the initial verification marks . . . . . R.29  
 Device is sealed . . . . . NoA, STP-4

**VISUAL EXAMINATION - INSTALLATION AND LOCATION . . . . . STP-7**

Device is installed in accordance with restrictions and conditions listed in the notice of approval and in accordance with manufacturer's instructions  
 Device is adequately supported  
 Device indicating and load receiving elements are positioned for customer's view (if applicable)  
 Clearance around load receptor  
 Device is properly levelled  
 Device is adequately protected

**VISUAL EXAMINATION - MARKING . . . . . STP-3**

Device is marked with the required information  
 Marking is located as required  
 Marking is permanent (if applicable)  
 Marking plate is permanently attached to the device

**VISUAL EXAMINATION - INDICATING ELEMENT . . . . . STP-5**

(Electronic)  
 Display Test (Segment)  
 Indicated and recorded values are adequately defined  
 Defining words and symbols for annunciators (Tare Entered, Gross and Net Weight, Center-of-Zero) are readable

(Mechanical)  
 Scale marks, pointers and poise are in good condition  
 Defining words and symbols are readable  
 Zero setting material is enclosed and secured  
 Balancing ball is in good condition and secured in place

<b>Field Inspection Manual</b>	Part: <b>2 - IPO</b>	Section: <b>6</b>	Page: <b>2 of 2</b>
<b>Non Automatic Weighing Devices</b>	Issued: <b>2004-03-01</b>	Revision Number: <b>Original</b>	

**TYPE 3.10 SINGLE-POINT SUSPENDED SCALES**

**VISUAL EXAMINATION - RECORDING ELEMENT (PRINTER) . . . . . STP-6**

Device prints the required values  
 Printed values are adequately defined

**DEVICE CONFIGURATION (ELECTRONIC)**

Device configured as prescribed by the NOA . . . . . STP-2

Zero Setting Mechanism Range ( 4% of Max or more) . . . . . STP-8

\*Initial Zero Setting Mechanism Range (20% of Max or more)  
 AZTM Maximum Range (0.6 e)

\*Manual Entries of Gross Weights . . . . . STP-9

\*Sleep Mode Test . . . . . STP-10

Tare (Platter, Keyboard, and Pre-programmed Tare Entry) . . . . . STP-11

Free Floating Weight Signal . . . . . STP-12

**PERFORMANCE**

Load Discrimination Test (Near Zero) . . . . . STP-14

Increasing Test . . . . . STP-13

Eccentricity Test . . . . . STP-15

Load Discrimination (Max) . . . . . STP-14

Agreement of Registration . . . . . STP-17

Display Blanking Tests (Zero, Tare) . . . . . STP-18

Decreasing and Return-to-Zero Test . . . . . STP-13

Repeatability Test . . . . . STP-16

Motion Detection Test . . . . . STP-19

Accuracy of Price Computation . . . . . STP-20

Mathematical Concordance of Tare, Net and Gross Weight . . . . . STP-21

\*Off-Level Test (if applicable) . . . . . STP-22

Disturbance Test (Electromagnetic Interference and Radio Frequency Interference, Vibrations) . . STP-23

**Note:** Tests marked with the star \* are performed at the initial inspection only.

**REVISION**

Original document

<b>Field Inspection Manual</b>	<b>Part: 2 - IPO</b>	<b>Section: 7</b>	<b>Page: 1 of 3</b>
<b>Non Automatic Weighing Devices</b>	<b>Issued: 2004-03-01</b>	<b>Revision Number: Original</b>	

**TYPE 4.10 HOPPER OR TANK SCALES**

**APPLICATION**

Electronic or mechanical hopper scales or tank scales

**EQUIPMENT**

Inspector's weight kit, local standards in sufficient amount and capacity, material for strain or substitution tests.

**USE**

Device is approved for trade use ..... NoA, Act Section 8  
 Device is suitable for the actual use ..... STP-1  
 Device has been initially inspected (if applicable) and bears the initial verification marks ..... R.29  
 Device is sealed ..... NoA, STP-4

**VISUAL EXAMINATION - INSTALLATION AND LOCATION ..... STP-7**

Device is installed in accordance with restrictions and conditions listed in the notice of approval and in accordance with manufacturer's instructions  
 Device is adequately supported  
 Device indicating and load receiving elements are positioned for customer's view (if applicable)  
 Visibility of the weighing element  
 Clearance around load receptor  
 Device is properly levelled  
 Device is adequately protected  
 Local standards and test load can be brought to the device and used for inspection  
 Automatic test weight lifting system does not adversely interfere on the scale performance  
 Dust/fume eliminator does not affect device performance

**VISUAL EXAMINATION - MARKING ..... STP-3**

Device is marked with the required information  
 Marking is located as required  
 Marking is permanent (if applicable)  
 Marking plate is permanently attached to the device

<b>Field Inspection Manual</b>	<b>Part: 2 - IPO</b>	<b>Section: 7</b>	<b>Page: 2 of 3</b>
<b>Non Automatic Weighing Devices</b>	<b>Issued: 2004-03-01</b>	<b>Revision Number: Original</b>	

**TYPE 4.10 HOPPER OR TANK SCALES**

**VISUAL EXAMINATION - INDICATING ELEMENT . . . . . STP-5**

(Electronic)  
 Display Test (Segment)  
 Indicated and recorded values are adequately defined  
 Defining words and symbols for annunciators (Tare Entered, Gross and Net Weight, Center-of-Zero) are readable

(Mechanical)  
 Scale marks, pointers and poise are in good condition  
 Defining words and symbols are readable  
 Zero setting material is enclosed and secured  
 Balancing ball is in good condition and secured in place

**VISUAL EXAMINATION - RECORDING ELEMENT (PRINTER) . . . . . STP-6**

Device prints the required values  
 Printed values are adequately defined

**DEVICE CONFIGURATION (ELECTRONIC)**

Device configured as prescribed by the NOA . . . . . STP-2

Zero Setting Mechanism Range ( 4% of Max or more) . . . . . STP-8

\*Initial Zero Setting Mechanism Range (20% of Max or more)  
 AZTM Maximum Range (0.6 e)

\*Manual Entries of Gross Weights . . . . . STP-9

\*Sleep Mode Test . . . . . STP-10

Tare (Platter, Keyboard, and Pre-programmed Tare Entry) . . . . . STP-11

Free Floating Weight Signal . . . . . STP-12

**PERFORMANCE**

Load Discrimination Test (Near Zero) . . . . . STP-14

Increasing Test . . . . . STP-13

Eccentricity Test . . . . . STP-15

Load Discrimination (Max) . . . . . STP-14

Agreement of Registration . . . . . STP-17

Display Blanking Tests (Zero, Tare) . . . . . STP-18

Decreasing and Return-to-Zero Test . . . . . STP-13

Repeatability Test . . . . . STP-16

Motion Detection Test . . . . . STP-19

Accuracy of Price Computation . . . . . STP-20

Mathematical Concordance of Tare, Net and Gross Weight . . . . . STP-21

Disturbance Test (Electromagnetic Interference and Radio Frequency Interference, Vibrations) . . STP-23

<b>Field Inspection Manual</b>	Part: <b>2 - IPO</b>	Section: <b>7</b>	Page: <b>3 of 3</b>
<b>Non Automatic Weighing Devices</b>	Issued: <b>2004-03-01</b>	Revision Number: <b>Original</b>	

**TYPE 4.10 HOPPER OR TANK SCALES**

**MULTIDECK WEIGHING SYSTEMS**

See the requirements for multiple load receiving elements systems  
and test procedures described in ..... STP-26

**NOTE:** Tests marked with the star \* are performed at the initial inspection only.

**REVISION**

Original document

<b>Field Inspection Manual</b>	Part: <b>2 - IPO</b>	Section: <b>8</b>	Page: <b>1 of 2</b>
<b>Non Automatic Weighing Devices</b>	Issued: <b>2004-04-01</b>	Revision Number: <b>Original</b>	

**TYPE 5.10 CRANE SCALES**

**APPLICATION**

Mechanical, electronic or hydraulic single point suspended scales with a capacity exceeding 1000 kg (2000 lb).

**EQUIPMENT**

Inspector's weight kit, local standards of sufficient number and capacity, material for strain load testing, and means of suspending standards.

**USE**

- Device is approved for trade use . . . . . NoA, Act Section 8
- Device is suitable for the actual use . . . . . STP-1
- Device has been initially inspected (if applicable) and bears the initial verification marks . . . . . R.29
- Device is sealed . . . . . NoA, STP-4

**VISUAL EXAMINATION - INSTALLATION AND LOCATION . . . . . STP-7**

- Device is installed in accordance with restrictions and conditions listed in the notice of approval and in accordance with manufacturer's instructions
- Device is adequately supported
- Device indicating and load receiving elements are positioned for customer's view (if applicable)
- Load receiving element can be observed from indicator's reading position
- Clearance around load receptor
- Device is adequately protected
- Adequate facilities to apply test standards or test product are provided

**VISUAL EXAMINATION - MARKING . . . . . STP-3**

- Device is marked with the required information
- Marking is located as required
- Marking is permanent (if applicable)
- Marking plate is permanently attached to the device

**VISUAL EXAMINATION - INDICATING ELEMENT . . . . . STP-5**

- (Electronic)
- Display Test (Segment)
- Indicated and recorded values are adequately defined
- Defining words and symbols for annunciators (Tare Entered, Gross and Net Weight, Center-of-Zero) are readable

- (Mechanical)
- Scale marks, pointers and poise are in good condition
- Defining words and symbols are readable
- Zero setting material is enclosed and secured
- Balancing ball is in good condition and secured in place

<b>Field Inspection Manual</b>	Part: <b>2 - IPO</b>	Section: <b>8</b>	Page: <b>2 of 2</b>
<b>Non Automatic Weighing Devices</b>	Issued: <b>2004-04-01</b>	Revision Number: <b>Original</b>	

**TYPE 5.10 CRANE SCALES**

**VISUAL EXAMINATION - RECORDING ELEMENT (PRINTER) . . . . . STP-6**

Device prints the required values  
 Printed values are adequately defined

**DEVICE CONFIGURATION (ELECTRONIC)**

Device configured as prescribed by the NOA . . . . . STP-2

Zero Setting Mechanism Range ( 4% of Max or more) . . . . . STP-8

\*Initial Zero Setting Mechanism Range (20% of Max or more)  
 AZTM Maximum Range (0.6 e)

\*Manual Entries of Gross Weights . . . . . STP-9

\*Sleep Mode Test . . . . . STP-10

Tare (Platter, Keyboard, and Pre-programmed Tare Entry) . . . . . STP-11

Free Floating Weight Signal . . . . . STP-12

**PERFORMANCE**

Load Discrimination Test (Near Zero) . . . . . STP-14

Increasing Test and Strain Test . . . . . STP-13

Load Discrimination (Max) . . . . . STP-14

Agreement of Registration . . . . . STP-17

Display Blanking Tests (Zero, Tare) . . . . . STP-18

Decreasing and Return-to-Zero Test . . . . . STP-13

Repeatability Test . . . . . STP-16

Motion Detection Test . . . . . STP-19

Accuracy of Price Computation . . . . . STP-20

Mathematical Concordance of Tare, Net and Gross Weight . . . . . STP-21

Disturbance Test (Electromagnetic Interference and Radio Frequency Interference, Vibrations) . . STP-23

**Note:** Tests marked with the star \* are performed at the initial inspection only.

**REVISION**

Original document

<b>Field Inspection Manual</b>	Part: <b>2 - IPO</b>	Section: <b>9</b>	Page: <b>1 of 2</b>
<b>Non Automatic Weighing Devices</b>	Issued: <b>2004-03-01</b>	Revision Number: <b>Original</b>	

**TYPE 7.10 OVERHEAD TRACK SCALES**

**APPLICATION**

Electronic or mechanical overhead monorail scale; or combination of monorail/platform scale.

**EQUIPMENT**

Inspector's weight kit, local standards of sufficient number and capacity, weight suspension equipment.

**USE**

- Device is approved for trade use . . . . . NoA, Act Section 8
- Device is suitable for the actual use . . . . . STP-1
- Device has been initially inspected (if applicable) and bears the initial verification marks . . . . . R.29
- Device is sealed . . . . . NoA, STP-4

**VISUAL EXAMINATION - INSTALLATION AND LOCATION . . . . . STP-7**

- Device is installed in accordance with restrictions and conditions listed in the notice of approval and in accordance with manufacturer's instructions
- Adequate facilities to apply test standards or test product are provided
- Device is adequately supported; holding rods and brackets affixed solidly
- Device indicating and load receiving elements are positioned for customer's view (if applicable)
- Load receiving element can be observed from indicator's reading position
- Clearance around overhead track
- Device is adequately protected

**VISUAL EXAMINATION - MARKING . . . . . STP-3**

- Device is marked with the required information
- Marking is located as required
- Marking is permanent (if applicable)
- Marking plate is permanently attached to the device

**VISUAL EXAMINATION - INDICATING ELEMENT . . . . . STP-5**

- (Electronic)
- Display Test (Segment)
- Indicated and recorded values are adequately defined
- Defining words and symbols for annunciators (Tare Entered, Gross and Net Weight, Center-of-Zero) are readable

- (Mechanical)
- Scale marks, pointers and poise are in good condition
- Defining words and symbols are readable
- Zero setting material is enclosed and secured
- Balancing ball is in good condition and secured in place

<b>Field Inspection Manual</b>	Part: <b>2 - IPO</b>	Section: <b>9</b>	Page: <b>2 of 2</b>
<b>Non Automatic Weighing Devices</b>	Issued: <b>2004-03-01</b>	Revision Number: <b>Original</b>	

**TYPE 7.10 OVERHEAD TRACK SCALES**

**VISUAL EXAMINATION - RECORDING ELEMENT (PRINTER) . . . . . STP-6**

Device prints the required values  
 Printed values are adequately defined

**DEVICE CONFIGURATION (ELECTRONIC)**

Device configured as prescribed by the NOA . . . . . STP-2

Zero Setting Mechanism Range ( 4% of Max or more) . . . . . STP-8

\*Initial Zero Setting Mechanism Range (20% of Max or more)  
 AZTM Maximum Range (0.6 e)

\*Manual Entries of Gross Weights . . . . . STP-9

\*Sleep Mode Test . . . . . STP-10

Tare (Platter, Keyboard, and Pre-programmed Tare Entry) . . . . . STP-11

Free Floating Weight Signal . . . . . STP-12

**PERFORMANCE**

Load Discrimination Test (Near Zero) . . . . . STP-14

Increasing Test . . . . . STP-13

Eccentricity Test . . . . . STP-15

Load Discrimination (Max) . . . . . STP-14

Agreement of Registration . . . . . STP-17

Display Blanking Tests (Zero, Tare) . . . . . STP-18

Decreasing and Return-to-Zero Test . . . . . STP-13

Repeatability Test . . . . . STP-16

Motion Detection Test . . . . . STP-19

Accuracy of Price Computation . . . . . STP-20

Mathematical Concordance of Tare, Net and Gross Weight . . . . . STP-21

Disturbance Test (Electromagnetic Interference and Radio Frequency Interference, Vibrations) . . STP-23

**MULTI-DECK WEIGHING SYSTEMS (COMBINATION MONORAIL/PLATFORM SCALE) . . . . . STP-26**

Selection of the weighing element (Interlock)  
 Identification of the load receiving element in use (Electronic)  
 Identification of the load receiving element on the ticket

In the case of a combination monorail/platform scale, the monorail scale and the platform scale are tested separately. See IPO for platform scales.

**NOTE:** Tests marked with the star \* are performed at the initial inspection only.

**REVISION**

Original document

<b>Field Inspection Manual</b>	Part: <b>2 - IPO</b>	Section: <b>10</b>	Page: <b>1 of 2</b>
<b>Non Automatic Weighing Devices</b>	Issued: <b>2008-01-01</b>	Revision Number: <b>1</b>	

**TYPE 8.10 ON-BOARD WEIGHING SYSTEMS**

**APPLICATION**

Anhydrous Ammonia (NH<sub>3</sub>) Truck Mounted Weighing Systems, Weighing Systems Mounted on Lift Trucks, On-board Waste Pick up Weighing Systems, and other On-Board Systems.

**EQUIPMENT**

Inspector's weight kit, local standards in sufficient number and capacity, and material for strain tests.

**USE**

Device is approved for trade use . . . . . NoA, Act Section 8  
 Device is suitable for the actual use . . . . . STP-1  
 Device has been initially inspected (if applicable) and bears the initial verification marks . . . . . R.29  
 Device is sealed . . . . . NoA, STP-4

**VISUAL EXAMINATION - INSTALLATION AND LOCATION . . . . . STP-7**

Device is installed in accordance with restrictions and conditions listed in the notice of approval and in accordance with manufacturer's instructions  
 Weighing element is adequately supported; load cell mounting is adequate  
 Device indicating and weighing elements are positioned for customer's view (if applicable), or a secondary indicator is provided  
 Load receiving element can be observed from indicator's reading position  
 Clearance around load receptor  
 Device is adequately protected  
 Means are provided to apply standards and testing material

**VISUAL EXAMINATION - MARKING . . . . . STP-3**

Device is marked with the required information  
 Marking is located as required  
 Marking is permanent (if applicable)  
 Marking plate is permanently attached to the device

**VISUAL EXAMINATION - INDICATING ELEMENT . . . . . STP-5**

(Electronic)  
 Display Test (Segment)  
 Indicated and recorded values are adequately defined  
 Defining words and symbols for annunciators (Tare Entered, Gross and Net Weight, Center-of-Zero) are readable

**VISUAL EXAMINATION - RECORDING ELEMENT (PRINTER) . . . . . STP-6**

Device prints the required values  
 Printed values are adequately defined

Field Inspection Manual	Part: 2 - IPO	Section: 10	Page: 2 of 2
Non Automatic Weighing Devices	Issued: 2008-01-01	Revision Number: 1	

**TYPE 8.10 ON-BOARD WEIGHING SYSTEMS**

**DEVICE CONFIGURATION (ELECTRONIC)**

Device configured as prescribed by the NOA ..... STP-2

Zero Setting Mechanism Range ( 4% of Max or more) ..... STP-8

\*Initial Zero Setting Mechanism Range (20% of Max or more)

AZTM Maximum Range (0.6 e)

\*Manual Entries of Gross Weights ..... STP-9

\*Sleep Mode Test ..... STP-10

Tare (Platter, Keyboard, and Pre-programmed Tare Entry) ..... STP-11

Free Floating Weight Signal ..... STP-12

**PERFORMANCE**

Load Discrimination Test (No Load) ..... STP-14

Increasing Test (Strain Test) ..... STP-13

Eccentricity Test ..... STP-15

Load Discrimination Test (Max) ..... STP-14

Agreement of Registration ..... STP-17

Display Blanking Tests (Zero, Tare) ..... STP-18

Decreasing and Return-to-Zero Test ..... STP-13

Repeatability Test ..... STP-16

Motion Detection Test ..... STP-19

Accuracy of Price Computation (If applicable) ..... STP-20

Mathematical Concordance of Tare, Net and Gross Weight ..... STP-21

Disturbances Test (Electromagnetic Interference and Radio Frequency Interference, vibrations) . STP-23

Level Effect on Accuracy / Display Interlock/off Level Condition ..... STP-22

NH<sub>3</sub> On-Board Weighing Systems - Product Test ..... STP-27

**Note:** Test the performance of the device with different loads while the truck is moving (if it is the intended way of using the device); while the engine is running (increasing/decreasing load tests).

**Note:** Off level tests are performed at initial and subsequent inspections

**Note:** Tests marked with the star \* are performed at the initial inspection only.

**REVISION**

Rev1.  
- remove reference to static weighing.

<b>Field Inspection Manual</b>	Part: <b>2 - IPO</b>	Section: <b>11</b>	Page: <b>1 of 3</b>
<b>Non Automatic Weighing Devices</b>	Issued: <b>2004-11-26</b>	Revision Number: <b>1</b>	

**TYPE 9.10, 9.20, 9.30, 9.40      VEHICLE SCALES**

**APPLICATION**

Electronic or mechanical permanent or portable vehicle scales

**EQUIPMENT**

Inspector's weight kit, local standards in sufficient number and capacity, and material for strain tests.

**USE**

Device is approved for trade use ..... NoA, Act Section 8  
 Device is suitable for the actual use ..... STP-1  
 Device has been initially inspected (if applicable) and bears the initial verification marks ..... R.29  
 Device is sealed ..... NoA, STP-4

**VISUAL EXAMINATION - INSTALLATION AND LOCATION ..... STP-7**

Device is installed in accordance with restrictions and conditions listed in the notice of approval and in accordance with manufacturer's instructions  
 Device is adequately supported and properly levelled  
 Device indicating and load receiving elements are positioned for customer's view (if applicable), or a secondary indicator is provided  
 Load receiving element can be observed from indicator's normal reading position  
 Installation provide access to understructure of main elements (Pit entrance)  
 Installation of load cells, levers are adequate  
 Clearance around load receptor  
 Device is adequately protected  
 Approach and departure ends meet requirements  
 Local standards and test equipment can be brought to the device and used for inspection

**VISUAL EXAMINATION - MARKING ..... STP-3**

Device is marked with the required information  
 Marking is located as required  
 Marking is permanent (if applicable)  
 Marking plate is permanently attached to the device

<b>Field Inspection Manual</b>	Part: <b>2 - IPO</b>	Section: <b>11</b>	Page: <b>2 of 3</b>
<b>Non Automatic Weighing Devices</b>	Issued: <b>2004-11-26</b>	Revision Number: <b>1</b>	

**TYPE 9.10, 9.20, 9.30, 9.40 VEHICLE SCALES**

**VISUAL EXAMINATION - INDICATING ELEMENT . . . . . STP-5**

(Electronic)

Display Test (Segment)

Indicated and recorded values are adequately defined

Defining words and symbols for annunciators (Tare Entered, Gross and Net Weight, Center-of-Zero) are readable

(Mechanical)

Scale marks, pointers and poise are in good condition

Defining words and symbols are readable

Zero setting material is enclosed and secured

Balancing ball is in good condition and secured in place

Poise adjusting material is enclosed and held firmly in position

**VISUAL EXAMINATION - RECORDING ELEMENT (PRINTER) . . . . . STP-6**

Device prints the required values

Printed values are adequately defined

**DEVICE CONFIGURATION (ELECTRONIC)**

Device configured as prescribed by the NOA . . . . . STP-2

Zero Setting Mechanism Range ( 4% of Max or more) . . . . . STP-8

\*Initial Zero Setting Mechanism Range (20% of Max or more)

AZTM Maximum Range (0.6 e)

\*Manual Entries of Gross Weights . . . . . STP-9

\*Sleep Mode Test . . . . . STP-10

Tare (Platter, Keyboard, and Pre-programmed Tare Entry) . . . . . STP-11

Free Floating Weight Signal . . . . . STP-12

**PERFORMANCE**

Load Discrimination Test (Near Zero) . . . . . STP-14

Increasing Test (Strain Test) . . . . . STP-13

Eccentricity Test . . . . . STP-15

Load Discrimination (Max) . . . . . STP-14

Agreement of Registration . . . . . STP-17

Display Blanking Tests (Zero, Tare) . . . . . STP-18

Decreasing and Return-to-Zero Test . . . . . STP-13

Repeatability Test . . . . . STP-16

Motion Detection Test . . . . . STP-19

Mathematical Concordance of Tare, Net and Gross Weight . . . . . STP-21

Disturbance Test (Electromagnetic Interference and Radio Frequency Interference, Vibrations) . . STP-23

**NOTE:** Tests marked with the star \* are performed at the initial inspection only.

<b>Field Inspection Manual</b>	<b>Part: 2 - IPO</b>	<b>Section: 11</b>	<b>Page: 3 of 3</b>
<b>Non Automatic Weighing Devices</b>	<b>Issued: 2004-11-26</b>	<b>Revision Number: 1</b>	

**TYPE 9.10, 9.20, 9.30, 9.40      VEHICLE SCALES**

**WEIGH-IN/WEIGH-OUT SYSTEMS** ..... STP-24

**MULTI-DECK WEIGHING SYSTEMS** ..... STP-26

**UNATTENDED VEHICLE SCALES** ..... STP-25

**REVISION**

Rev.1 added device types 9.30 & 9.40 (Nov 2004)

<b>Field Inspection Manual</b>	Part: <b>2 - IPO</b>	Section: <b>12</b>	Page: <b>1 of 2</b>
<b>Non Automatic Weighing Devices</b>	Issued: <b>2004-03-01</b>	Revision Number: <b>Original</b>	

**TYPE 10.10 10.20 RAILWAY TRACK SCALES**

**APPLICATION**

Mechanical or electronic railway track scales, and combination railway track/vehicle scales

**EQUIPMENT**

Inspector's weight kit, at least one certified railway test car, local standards and suitable strain loads.

**NOTE:** When performing an initial inspection, refer to the Bulletin M-5 for the minimum amount of standards.

**USE**

Device is approved for trade use . . . . . NoA, Act Section 8  
 Device is suitable for the actual use . . . . . STP-1  
 Device has been initially inspected (if applicable) and bears the initial verification marks . . . . . R-29  
 Device is sealed . . . . . NoA, STP-4

**VISUAL EXAMINATION - INSTALLATION AND LOCATION . . . . . STP-7**

Device is installed in accordance with restrictions and conditions listed in the notice of approval and in accordance with manufacturer's instructions  
 Device is permanently installed on adequate foundations  
 Installation provide access to understructure of main elements (pit entrance)  
 Adequate approach and departure ends  
 Local standards and test equipment can be brought to the device and used for inspection  
 Device indicating and load receiving elements are positioned for customer's view (if applicable)  
 Load receiving element can be observed from indicator's reading position  
 Clearance around load receptor  
 Installation of load cells, levers are adequate  
 Device is adequately protected

**VISUAL EXAMINATION - MARKING . . . . . STP-3**

Device is marked with the required information  
 Marking is located as required  
 Marking is permanent (if applicable)  
 Marking plate is permanently attached to the device

**VISUAL EXAMINATION - INDICATING ELEMENT . . . . . STP-5**

(Electronic)  
 Display Test (Segment)  
 Indicated and recorded values are adequately defined  
 Defining words and symbols for annunciators (Tare Entered, Gross and Net Weight, Center-of-Zero) are readable

<b>Field Inspection Manual</b>	Part: <b>2 - IPO</b>	Section: <b>12</b>	Page: <b>2 of 2</b>
<b>Non Automatic Weighing Devices</b>	Issued: <b>2004-03-01</b>	Revision Number: <b>Original</b>	

**TYPE 10.10 10.20 RAILWAY TRACK SCALES**

(Mechanical)

- Scale marks, pointers and poise are in good condition
- Defining words and symbols are readable
- Zero setting material is enclosed and secured
- Balancing ball is in good condition and secured in place

**VISUAL EXAMINATION - RECORDING ELEMENT (PRINTER) . . . . . STP-6**

- Device prints the required values
- Printed values are adequately defined

**DEVICE CONFIGURATION (ELECTRONIC)**

Device configured as prescribed by the NOA . . . . . STP-2

Zero Setting Mechanism Range ( 4% of Max or more) . . . . . STP-8

\*Initial Zero Setting Mechanism Range (20% of Max or more)

AZTM Maximum Range (0.6 e)

\*Manual Entries of Gross Weights . . . . . STP-9

\*Sleep Mode Test . . . . . STP-10

Tare (Platter, Keyboard, and Pre-programmed Tare Entry) . . . . . STP-11

Free Floating Weight Signal . . . . . STP-12

**PERFORMANCE**

Load Discrimination Test (Near Zero) . . . . . STP-14

Increasing Test (Strain Test) . . . . . STP-13

Eccentricity Test . . . . . STP-15

Load Discrimination (Max) . . . . . STP-14

Agreement of Registration . . . . . STP-17

Display Blanking Tests (Zero, Tare) . . . . . STP-18

Decreasing and Return-to-Zero Test . . . . . STP-13

Repeatability Test . . . . . STP-16

Motion Detection Test . . . . . STP-19

Mathematical Concordance of Tare, Net and Gross Weight . . . . . STP-21

Disturbance Test (Electromagnetic Interference and Radio Frequency Interference, Vibrations) . . STP-23

**NOTE:** Tests marked with the star \* are performed at the initial inspection only.

**WEIGH-IN/WEIGH-OUT SYSTEMS . . . . . STP-24**

**WEIGHING SYSTEMS WITH MULTIPLE WEIGHING ELEMENTS . . . . . STP-26**

**REVISION**

Original document

<b>Field Inspection Manual</b>	<b>Part: 3 - STP</b>	<b>Section: 1</b>	<b>Page: 1 of 1</b>
<b>Non Automatic Weighing Devices</b>	<b>Issued: 2004-03-01</b>	<b>Revision Number: Original</b>	

## **STP-1 SUITABILITY OF THE DEVICE FOR INTENDED USE**

### **REFERENCE**

Sections 61 and 62 of the Non Automatic Weighing Devices Specifications.

### **DEVICE CLASS**

The device must be of a class appropriate for the application. For instance, a Class II device must be used for weighing gemstones while a Class III device is not suitable. For a given application, the device may be of a higher accuracy Class than that required. For instance, a Class III HD device may be used for the weighing of gravel, land fill and raw material for road construction where a Class IIII device is normally sufficient.

### **MINIMUM NET LOAD**

The device must have a scale interval that permits an accurate determination of net quantity. The device must not be used to weigh net quantities less than the value obtained by multiplying the verification scale interval value times the factor indicated in Column 3 of section 62. For instance, in general applications, a device with a verification scale interval of 5 g cannot be used to weigh net loads of less than 100 g (5 g x 20).

Traders should be advised to select scales with scale intervals that are suitable for the range of commodity weights that they normally weigh.

### **REVISION**

Original Document

Field Inspection Manual	Part: 3-STP	Section: 2	Page: 1 of 4
Non Automatic Weighing Devices	Issued: 2009-02-01	Revision Number: 2	

## STP-2 LIMITATIONS AND CONDITIONS LISTED IN THE NOTICE OF APPROVAL

### REFERENCE

Section 55 of the *Specifications Relating to Non-automatic Weighing Devices (1998)*.

Notices of Approval (NoA) provide limitations and conditions for the configuration, installation and use of devices and major elements. Inspectors ensure that weighing devices are configured, installed and used in accordance with those limitations and conditions. Such evaluation is normally performed when the device is initially inspected. The following is a list of the most common limitations, and conditions that appear in NoAs.

### CLASS DESIGNATION

The class designation is the first indication of the device accuracy. The inspector ensures that the device (or the major element approved separately), is marked with the class designation specified in the NoA, and that the device is of a class authorized for the application in which it is used.

### MAXIMUM CAPACITY (*Max*)

The inspector ensures that the capacity (or weighing range) has not been set for a value higher than the maximum approved capacity of the device or the maximum capacity of one of the major elements that form the device.

### MINIMUM SCALE INTERVAL (*d*) OR VERIFICATION SCALE INTERVAL (*e*)

The inspector ensures that the device has not been set for a value of verification scale interval *e* or, if applicable, actual scale interval *d*, smaller than the minimum value authorized by the NoA.

### VALUE OF THE MINIMUM VERIFICATION SCALE INTERVAL (*e<sub>min</sub>*)

The inspector ensures that the device has not been configured for a value of verification scale interval smaller than the minimum value allowed by the NoA for the weighing element.

Field Inspection Manual	Part: 3-STP	Section: 2	Page: 2 of 4
Non Automatic Weighing Devices	Issued: 2009-02-01	Revision Number: 2	

## STP-2 LIMITATIONS AND CONDITIONS LISTED IN THE NOTICE OF APPROVAL

### Note

Approvals without a specific division size listed (devices approved pre-Nawds):

- Use the following table to determine the smallest acceptable  $e_{min}$  or,
- If the configured  $e_{min}$  is already below this value, contact the Gravimetric Specialist for further information and to ensure that the configuration is acceptable.

<b>Max</b> (Device Capacity)	<b><math>e_{min}</math></b> (finest interval)	<b>Max</b> (Device Capacity)	<b><math>e_{min}</math></b> (finest interval)
> 100 000 kg	20 kg	> 200,000 lb	50 lb
> 20 000 to 100 000 kg	10 kg	> 40,000 to 200,000 lb	20 lb
> 10 000 to 20 000 kg	5 kg	> 20,000 to 40,000 lb	10 lb
> 5 000 to 10 000 kg	2 kg	> 10,000 to 20,000 lb	5 lb
> 2 000 to 5 000 kg	1 kg	> 5,000 to 10,000 lb	2 lb
> 1 000 to 2 000 kg	0.5 kg	> 2,000 to 5,000 lb	1 lb
> 500 to 1 000 kg	0.2 kg	> 1,000 to 2,000 lb	0.5 lb
> 200 to 500 kg	0.1 kg	> 500 to 1,000 lb	0.2 lb
> 100 to 200 kg	0.05 kg	> 200 to 500 lb	0.1 lb
> 50 to 100 kg	0.02 kg	> 100 to 200 lb	0.05 lb
> 20 to 50 kg	0.01 kg	> 50 to 100 lb	0.02 lb
≤ 20 kg	0.005 kg	≤ 50 lb	0.01 lb

### MAXIMUM NUMBER OF SCALE INTERVALS ( $n_{max}$ )

The inspector ensures that the device has not been configured for a maximum number of scale intervals (counts) that exceeds the maximum number allowed by the NoA for the indicating element.

### TEMPERATURE RANGE

The inspector ensures that the scale is used within the temperature range for which it is approved. If the scale or the components of the scale are approved for the range from -10°C to +40°C, or if there is no temperature range marked on the device, there is no use limitation.

If a restricted temperature range is marked on the device, the inspector ensures that the device is used within that temperature range. For example, a Class III device is approved for a temperature range from +5°C to +35°C. This device must be used within that temperature range only.

Field Inspection Manual	Part: <b>3-STP</b>	Section: <b>2</b>	Page: <b>3 of 4</b>
<b>Non Automatic Weighing Devices</b>	Issued: <b>2009-02-01</b>	Revision Number: <b>2</b>	

## **STP-2 LIMITATIONS AND CONDITIONS LISTED IN THE NOTICE OF APPROVAL**

### **INSTALLATION - ENVIRONMENT**

NoAs may contain some other requirements and restrictions related to the installation of certain models of weighing devices or related to the environment in which they may be used.

### **MIX/MATCH OF MAJOR ELEMENTS**

Pursuant to the *Non Automatic Weighing Devices Specifications*, devices made of major detachable components may be tested by the Laboratory as a complete unit, or each major component of the device may be tested separately, according to the manufacturer's instructions. In the first case, the full acceptance limit of error (LOE) is allowed while in the latter case 0.7 times the acceptance limit of error is allowed. Section 10 of the *Non Automatic Weighing Devices Specifications* applies when major elements such as indicating or weighing elements are tested separately for approval by the Approval Services Laboratory (ASL). This LOE applies only to major components susceptible to produce measurement errors due to disturbances or influence factors. Only a portion of the full LOE (0.7 x LOE) is allowed when testing a major element separately. This ensures that the sum of errors that can be produced, when interfaced with other elements to form a complete weighing device, will not exceed the acceptance LOE.

Only major components tested separately can be mixed/matched to form other devices. For devices approved on or after the adoption of these specifications, NoAs indicate whether or not the major components of a device may be separated and matched with other approved components to form a new device.

### **DEVICE USAGE**

#### **Weight Classifiers**

Weight classifiers are configured to round the weight values up to the next scale interval. They are suitable for postal or courier applications where tariffs are set for ranges of weights; for instance, \$0.50 from 0 g up to and including 30 g. However, this type of scale is not suitable for general purposes where commodities are sold on the basis of weight as in grocery stores. On many scales, the turning point of the graduation (or the zone of uncertainty) can be set ( moved up or down closer to the graduation). The inspector ensures that weight classifiers are used only in authorized applications

#### **Devices not for use in direct sale**

Certain devices are designed for industrial applications only. They do not incorporate all the features required normally for direct sale applications. For instance, requirements for tares are more stringent for scales intended to be used in direct sale applications than those for industrial applications.

NoAs will indicate if a device is not for direct sale applications. Industrial devices that resemble devices used in direct sale applications are required to be marked accordingly.

Field Inspection Manual	Part: <b>3-STP</b>	Section: <b>2</b>	Page: <b>4 of 4</b>
Non Automatic Weighing Devices	Issued: <b>2009-02-01</b>	Revision Number: <b>2</b>	

## **STP-2 LIMITATIONS AND CONDITIONS LISTED IN THE NOTICE OF APPROVAL**

### **Counting Scales**

A device whose sole function is to count items is not included in the definition of "measuring machine" and is not a device as defined by the Act. As such, this type of device is not subject to the Act and Regulations. It requires neither approval nor inspection and may be used in trade.

A device that is capable of both counting and weighing items must have its weighing functions approved and inspected if it is to be used in trade.

### **REVISION**

Rev. 2

- added Max/e<sub>min</sub> table for pre-NAWDS devices.

Rev. 1 (01 Jan 2008)

- delete "to the Public" form Direct Sales references.
- add Counting Scale requirements for approval and inspection.
- correct several inconsistencies and general formatting issues.
- correct references to *Specifications Relating to Non-automatic Weighing Devices (1998)*.

Field Inspection Manual	Part: 3-STP	Section: 3	Page: 1 of 12
Non Automatic Weighing Devices	Issued: 2011-04-01	Revision Number: 3	

### STP-3 MARKING

#### REFERENCE

Sections 49 to 54 of the *Specifications Relating to Non-automatic Weighing Devices (1998)*.

[Bulletin M-24](#)

#### GENERAL

Complete weighing devices and major components (indicating elements and load receiving/weighing elements) of devices tested separately must be marked with certain information in the manner required by the *Specifications Relating to Non-automatic Weighing Devices (1998)*.

#### EVALUATION

In general, the completeness, appropriateness and permanence of the markings on complete weighing devices (price computing scales, bench scales, etc.) or major components (weight indicators and smaller weighing elements) are evaluated for compliance to specific criteria by the Approval Services Laboratory (ASL). However certain device types and major components are evaluated and tested in the field only (vehicle scales, hopper scales, etc.). In these cases, inspectors must ensure that the marking is complete, legible, located as required, permanent and permanently affixed to the major component. Markings shall be of a height reasonably appropriate to the size of the device. The height of characters should be at least 2 mm.

#### COMPLETE DEVICES IN THE SAME HOUSING OR COMPOSED OF NON DETACHABLE MAJOR COMPONENTS

Complete devices in the same housing or made of non detachable major components are only required to bear one series of markings.

#### COMPLETE DEVICES COMPOSED OF DETACHABLE COMPONENTS OR MAJOR COMPONENTS APPROVED SEPARATELY

Major components of complete devices must be marked individually if they can be separated and interfaced (mixed/matched) to other major components to form a device. Major components submitted for approval evaluation individually are tested separately and are also required to be marked individually.

#### **Max, e AND d** , IF DIFFERENT FROM **e**, ADJACENT TO THE WEIGHT DISPLAY

Section 52 of the *Specifications Relating to Non-automatic Weighing Devices (1998)* requires that **Max**, **e** and **d**, if different from **e**, be marked near the weight display of the device. On devices such as vehicle scales, **Max** and **e** are only known and marked on the indicating element (near the weight display) when the indicating element is matched to the weighing element. When such devices are initially inspected, the inspector therefore ensures that **Max** and **e** are marked as required.

#### ACCESSORIES

Remote (secondary) weight displays, slave modules such as printers, keyboards, cash registers and other similar modules that are used in conjunction with approved devices are not required to be marked if they perform no significant metrological functions.

Field Inspection Manual	Part: 3-STP	Section: 3	Page: 2 of 12
Non Automatic Weighing Devices	Issued: 2011-04-01	Revision Number: 3	

### STP-3 MARKING

#### EXTRACTS FROM THE APPROVAL EVALUATION MANUAL - NON AUTOMATIC WEIGHING DEVICES

Hereafter are the detailed marking requirements as extracted from the *Approval Evaluation Manual - Non Automatic Weighing Devices*. This extract is provided to ensure uniform and consistent application of the marking requirements in the field. Note that the numbering of the following sections correspond to the numbering used in the *Approval Evaluation Manual - Non Automatic Weighing Devices*.

#### 3.1 - MARKING - COMPLETE DEVICES

This section applies to complete devices in the same housing or complete devices made of major detachable components interfaced together and not intended to be separated and used in conjunction with other individually approved major components to form different devices. For such devices, only one series of information is required.

##### The device must be marked with:

3.1.1 - the name or trademark of the manufacturer or applicant.

3.1.2 - a model designation that positively identifies the device type or design.

3.1.3 - a distinctive serial number. The serial number must be prefaced by words, an abbreviation or a symbol that clearly identifies the number as the serial number.

3.1.4 - the appropriate Measurement Canada approval number. The approval number must be prefaced with words or an abbreviation that positively identifies the number as the Canadian approval number.

##### Acceptable Solutions

Canadian Approval AM-4145  
or MC AM- 4145  
or CND W&M AM-4145  
or AM-4145

3.1.5 - the accuracy class. The numerals I, II, III, III HD or IIII are the markings required to indicate the accuracy class. The numeral within an ellipse or a figure approximating an ellipse is the proper way to indicate the accuracy class. The word "Class" followed by the numeral is also acceptable.

3.1.6 - the maximum capacity **Max** that the device can weigh.

3.1.7 - the value of the verification scale interval **e**.

3.1.8 - the value of the actual scale interval **d**, if different from **e**. On Class III, III HD and IIII devices, multi-interval and multiple range devices, **d** must equal **e**.

##### NOTE:

1. **Max**, **e** and **d**, if different from **e**, must be marked near the weight display.

2. If a device has a separate display for customers, **Max**, **e** and **d**, if different from **e**, must be marked near both the operator and the customer weight displays.

Field Inspection Manual	Part: 3-STP	Section: 3	Page: 3 of 12
Non Automatic Weighing Devices	Issued: 2011-04-01	Revision Number: 3	

### STP-3 MARKING

3. **Max**, **e** and **d**, if different from **e**, must be marked for all units of measurement that can be displayed (i.e. pounds and kilograms).

#### Examples:

preferred	alternate	
<b>Max</b> 10 kg / 20 lb	10 kg x 5 g	10 kg (20 lb) x 5 g (0.01 lb)
<b>e</b> = 0.005 kg / 0.01 lb	20 lb x 0.01 lb	

4. The markings of **Max**, **e** and **d**, if different from **e**, near the weight display must reflect actual device operation. For instance, a device that is capable of being configured for either single or multiple range operation must be marked to reflect the configuration selected.

3.1.9 - the operating temperature range if different than -10°C to +40°C.  
for Class I devices, the temperature range must be at least 5°C;  
for Class II devices, at least 15°C;  
for Class III, III HD and IIII devices, at least 30°C.

**Note:** Multiple range and multi-interval devices must be marked with the weight ranges and the corresponding scale intervals. Devices with more than one class designation must be marked with each class designation in clear association with **Max**, **e** and **d**, if different from **e**, and the temperature range, if they are different for each class.

**Note:** Markings for **e** and/or **d** must be in the same units as those for **Max**. For the purposes of this marking requirement, if **Max** is stated in kilograms, **e/d** may be in either grams or kilograms (preferred). If **Max** is stated in grams, then **e/d** must be in grams also.

### Acceptable solutions

#### 1 - Multi-interval device

preferred	alternate
<b>Max</b> 3 / 6 kg (6 / 15 lb)	0-3 kg (0-6 lb) x 1 g (0.002 lb)
<b>e</b> = 1 / 2 g (0.002 / 0.005 lb)	3-6 kg (6-15 lb) x 2 g (0.005 lb)

#### 2 - Device with more than one weighing range

$W_1$	$W_2$
<b>Max</b> 3 kg (6 lb)	6 kg (15 lb)
<b>e</b> = 1 g (0.002 lb)	2 g (0.005 lb)

Field Inspection Manual	Part: 3-STP	Section: 3	Page: 4 of 12
Non Automatic Weighing Devices	Issued: 2011-04-01	Revision Number: 3	

### STP-3 MARKING

#### 3 - Device with weighing ranges in different accuracy classes and restricted temperature ranges

$W_1$	$W_2$
II	III
<b>Max</b> 3 kg	15 kg
<b>e</b> = 0.1 g	<b>e</b> = 10 g
<b>d</b> = 0.01 g	<b>d</b> = <b>e</b>
10°C / 30°C	0°C / 35°C

3.1.10 - the verification marks. The device must have an area, either on the marking plate itself or on the device adjacent to the marking plate, suitable for the application of the verification marks. The surface of this area must be at least 1.3 x 2.5 cm (½" x 1").

#### 3.2 - MARKING - INDICATING ELEMENTS

This section applies to indicating elements that are evaluated and tested separately. Such indicating elements are either submitted for approval evaluation separately or are major detachable components of a complete device and are intended to be used in conjunction with approved and compatible weighing elements to form different devices.

##### The indicating element must be marked with:

3.2.1 - the name or trademark of the manufacturer or applicant.

3.2.2 - a model designation that positively identifies the device type or design.

3.2.3 - a distinctive serial number. The serial number must be prefaced by words, an abbreviation or a symbol that clearly identifies the number as the serial number.

3.2.4 - the appropriate Measurement Canada approval number. The approval number must be prefaced with words or an abbreviation that positively identifies the number as the Canadian approval number. See acceptable solutions in section 3.1.4.

3.2.5 - the accuracy class. The numerals I, II, III, III HD or IIII are the markings required to indicate the accuracy class. The numeral within an ellipse or a figure approximating an ellipse is the proper way to indicate the accuracy class. The word "Class" followed by the numeral is also acceptable.

3.2.6 - the maximum number of scale intervals  $n_{max}$ . If the indicating element is approved for two accuracy classes and has a different maximum number of scale intervals for each accuracy class, both maxima must be marked in clear association to the accuracy class designation.

Field Inspection Manual	Part: 3-STP	Section: 3	Page: 5 of 12
Non Automatic Weighing Devices	Issued: 2011-04-01	Revision Number: 3	

### STP-3 MARKING

#### Acceptable Solutions

Class III / III HD  
 $n_{max}$  3000 / 8000

or

III	III HD
$n_{max}$ 3000	8000

or

III	$n_{max}$ 3000
III HD	$n_{max}$ 8000

3.2.7 - the maximum capacity **Max**, the value of the verification scale interval **e** and the value of the actual scale interval **d**, if different from **e**, must be marked on the indicator near the weight display when it is interfaced with a weighing element to form a device. This marking reflects the limitation of the complete weighing device. See the notes and examples below sections 3.1.8 and 3.1.9.

**NOTE :** For multiple range devices, multi-interval devices and indicators with more than one accuracy class designation, see the note below section 3.1.9.

3.2.8 - the operating temperature range, if different than -10°C to +40°C.  
for Class I indicators, the temperature range must be at least 5°C;  
for Class II indicators, at least 15°C;  
for Class III, III HD and IIII indicators, at least 30°C.

3.2.9 - the verification marks. The indicator must have an area, either on the marking plate itself or on the indicator adjacent to the marking plate, suitable for the application of the verification marks. The surface of this area must be at least 1.3 x 2.5 cm (½" x 1").

### 3.3 - MARKING - SOFTWARE

3.3.1 - For software that is evaluated separate from hardware, the identifying information (manufacturer name, model number and approval number) must be visible on the video display terminal or printable when called up from the menu, or be continually displayed. For further information regarding the approval evaluation of software, consult the Terms and Conditions for the Approval of Metrological Software on the Measurement Canada Web site.

### 3.4 - MARKING - LOAD RECEIVING/WEIGHING ELEMENTS

This section applies to weighing elements that are evaluated and tested separately. Such weighing elements are either submitted to approval evaluation separately or are major detachable components of a complete device and are intended to be used in conjunction with approved and compatible indicating elements to form different devices.

Field Inspection Manual	Part: 3-STP	Section: 3	Page: 6 of 12
Non Automatic Weighing Devices	Issued: 2011-04-01	Revision Number: 3	

### STP-3 MARKING

#### The weighing element must be marked with:

3.4.1 - the name or trademark of the manufacturer or applicant.

3.4.2 - a model designation that positively identifies the device type or design.

3.4.3 - a distinctive serial number. The serial number must be prefaced by words, an abbreviation or a symbol that clearly identifies the number as the serial number.

3.4.4 - the appropriate Measurement Canada approval number. The approval number must be prefaced with words or an abbreviation that positively identifies the number as the Canadian approval number. See acceptable solutions in section 3.1.4.

3.4.5 - the accuracy class. The numerals I, II, III, III HD or IIII are the markings required to indicate the accuracy class. The numeral within an ellipse or a figure approximating an ellipse is the proper way to indicate the accuracy class. The word "Class" followed by the numeral is also acceptable.

3.4.6 - the maximum capacity **Max** that the weighing element can weigh.

3.4.7 - the value of the minimum verification scale interval  $e_{min}$  for which the weighing element complies with the requirements and can be set.

3.4.8 - the maximum number of scale intervals  $n_{max}$  for which the weighing element complies with the requirements and can be set.

3.4.9 - the operating temperature range, if different than -10°C to +40°C.  
for Class I weighing elements, the temperature range must be at least 5°C;  
for Class II weighing elements, at least 15°C;  
for Class III, III HD and IIII weighing elements, at least 30°C.

### 3.5 - MARKING - LOAD CELLS

Load cells which are required to be approved by the Notice of Approval (NOA) for the Load Receiving and Weighing element must be suitably marked in order to allow complete identification of the load cell and its approved parameters. The following table identifies which markings are required and where the markings may be located. Markings listed in the MC column are applicable to these load cells. Other load cells do not require marking at this time.

<b>Field Inspection Manual</b>	Part: <b>3-STP</b>	Section: <b>3</b>	Page: <b>7 of 12</b>
<b>Non Automatic Weighing Devices</b>	Issued: <b>2011-04-01</b>	Revision Number: <b>3</b>	

### STP-3 MARKING

Required Load Cell Markings				
Item	Markings	NTEP / Pub 14	OIML / R60	MC
1	Manufacturer Name or Trademark	1 (G-S.1)	1	1
2	Manufacturer Model	1 (G-S.1)	1	1
3	Serial Number	1 (G-S.1)	1	1
4	Year of Manufacture	N/A	2	3
5	Certificate Number	1(G-S.1)	2	2
6	Accuracy Class OIML or NTEP	2	1	2
7	Temperature Limits (if other than -10 °C to 40 °C)	2	2	2
8	Number of Divisions (nMax)	2	2	2
9	Single/Multiple Cell designation	2	N/A	N/A
10	Direction of Loading (if not obvious)	2	2	2
11	Minimum Deadload ( $E_{min}$ )	2	2	2
12	Load Cell Capacity ( $E_{max}$ )	2	1	2
13	Load Cell Safe Limit ( $E_{lim}$ )	2	2	2
14	Minimum Number of Verification Interval ( $V_{min}$ )	2	2	2
15	Humidity Classification	N/A	2	3
16	Electrical Characteristics (mv/V, impedance, etc.)	N/A	2	3
17	Apportionment Factor ( $p_{LC}$ )	N/A	2	3
18	Relative $V_{min} = "Y"$	N/A	3	3
19	Relative DR = "Z"	N/A	3	3

Applicable to strain gauge load cells only.

Digital cells will report number of counts at  $E_{max}$  for cell rated output (mv/V)

#### Key

- 1 - Required to be marked on Cell
- 2 - Required to be available (optional on cell or accompanying documentation)
- 3 - Optional Information
- N/A - Not Applicable

Field Inspection Manual	Part: 3-STP	Section: 3	Page: 8 of 12
Non Automatic Weighing Devices	Issued: 2011-04-01	Revision Number: 3	

### STP-3 MARKING

#### Reference

G-S.1 US National Institute for Standards & Technology (NIST) Handbook 44, General Code, S.1  
 Pub 14 US National Type Evaluation Program (NTEP), Publication 14  
 R60 International Organization of Legal Metrology, OIML R60

### 3.6 - MARKING - READABILITY, LOCATION AND PERMANENCE

3.6.1 - The required information must be complete, legible, accessible and durable. If necessary for clarity, there must be defining words or authorized symbols associated with the numbers (i.e. model numbers, temperature range, etc.). See the list of acceptable defining words and symbols in Appendix A. The height of capital letters must be at least 2 mm.

3.6.2 - The required information must be appropriately located. Markings may be on either a marking plate affixed to a permanent part of the device, on the device itself, or both. Information that identifies the device (manufacturer name or trademark, model, serial and approval numbers) should be grouped together. **Max**, **e** and **d** (if different from **e**) must be marked near the weight display(s). See the note below sections 3.1.8 and 3.1.9 for additional information.

3.6.3 - The marking must be visible without having to remove a permanent part of the device or having to move or lift the device. Markings must be available with minimum effort and be accessible without disassembly requiring the use of special tools or equipment.

#### Acceptable Locations

(1) Markings (and/or the marking plate) may be located on the top, sides or front of the device. Markings may be located beneath the platter and fastened to the scale structure if the platter is easily removable (small devices such as computing scales and bench scales).

(2) Weighing elements. The required information must be on a surface that is an integral part of the chassis. If the information is on a label or a plate, it must be permanently attached to the device. A plate may be riveted or welded but not affixed with bolts or screws.

(3) Weighing elements of large scales. Identification information for the weighing elements of vehicle, axle load, floor, livestock, railroad track and large hopper or tank scales must be located near the point where the signal leaves the weighing element (this would be the transverse lever on a mechanical scale and on, or near, the junction box on an electronic scale). In the case of built-in weighing elements (flush mounted), the required information can be placed on the scale chassis and be accessible by the removal of a cover plate.

#### Non Acceptable Locations

- (1) Under the scale
- (2) Inside a cabinet
- (3) On the back of the device or indicating element if it is difficult to move and is likely to be located near a wall
- (4) Marking plate affixed to the platter

3.6.4 - If **Max**, **e** and **d**, if different from **e**, are displayed electronically, such as on a video display terminal, then they must be adjacent to the weight display and continuously displayed when the system is in the weighing mode.

Field Inspection Manual	Part: 3-STP	Section: 3	Page: 9 of 12
Non Automatic Weighing Devices	Issued: 2011-04-01	Revision Number: 3	

### STP-3 MARKING

3.6.5 - The lettering must be permanent. This requirement also applies to words and symbols for measurement units near the weight display and to words and symbols that identify or indicate the status of metrologically significant annunciators.

3.6.6 - Plates or other materials (decals, labels or badges) on which the required information is marked must be made of durable material and permanently affixed to the device so that they cannot be easily removed and affixed to another device.

### 3.7 - MARKING - SPECIAL APPLICATIONS

Certain device types are designed for specific applications. Such devices may incorporate features, perform certain functions or operate in a particular fashion that would not be acceptable for all applications. Since these devices may not meet all the usual requirements, their use is restricted to the specific applications for which they were designed. The device restriction must therefore be permanently and clearly marked adjacent to both the operator and customer weight displays.

#### Some examples:

**Weight Classifiers** - Digital weight classifiers round weight values up to the next scale interval. They are designed to classify packages within price ranges for shipping, courier or postal applications. Weight classifiers would therefore not be appropriate for use in grocery store applications. Their use is restricted and they must be marked with the following: "*Weight Classification Only*" or "*Weight Classifier*" or "*Postal Scale*".

**Industrial Devices** - Certain devices are designed for industrial applications. They do not incorporate features that are normally required for devices used in direct sales to consumers. For instance, they may not have a display for consumers; the tare feature may not comply with the requirements for devices used in direct sale applications, etc. These devices, if they resemble devices intended to be used in direct sale applications, must be marked as follows to indicate that they are designed for industrial use only: "*Not for Use in Direct Sales*" or similar language.

**Devices in Auxiliary Housings** - There are situations where the device owner deems it necessary to place an approved indicating element inside an auxiliary housing. As this can lead to concerns for the inspector and device user, the following requirements must be met. The indicating element must retain its primary serial number plate and original case. All initial inspection markings must be on this primary plate which must remain attached to the device. If the interior of the auxiliary housing is not readily accessible (quick release latches or less than 4 easily removed bolts), then the device information must be duplicated on a second identification plate attached to the exterior of the auxiliary housing. No initial inspection marks are to be made on this second plate. The auxiliary housing must have provisions for application of a "lead and wire" or other mechanical seal (not adhesive paper). In all cases, it will be up to the inspector to satisfy themselves that the device inside the enclosure is the same as the device identified on the external duplicate identification plate. If any question remains, the inspector may request that the auxiliary housing be opened in order to examine the actual indicating element.

**Precious Metals/ Gemstones** - Certain devices are designed and inspected for use in trade transactions for precious metals or gemstones. These devices generally require different test equipment and may have other restrictions or requirements not generally applicable to other trade devices. These devices must be marked as per the Notice of Approval (NoA). Scales which weigh in troy ounces must also be marked "*Troy Ounces may only be used to weigh Precious Metals*" and scales which weigh in carats, must be marked "*Carats may only be used to weigh Gemstones*" or similar language.

Field Inspection Manual	Part: 3-STP	Section: 3	Page: 10 of 12
Non Automatic Weighing Devices	Issued: 2011-04-01	Revision Number: 3	

### STP-3 MARKING

#### 3.8 - MARKING - OPERATIONAL CONTROLS, INDICATIONS AND FEATURES

The marking of operational controls such as keys, push buttons and switches that are strictly for operator use is not required by Measurement Canada. Keys that are visible only to the scale operator need only be marked to the extent that a trained operator can understand the function of each key. It is however recommended that internationally recognized words and symbols be used.

Annunciators that are metrologically significant must be marked with words or acceptable symbols. The following are some examples of metrologically significant annunciators: centre of zero, net, gross and tare weight indications, identification of the weighing element in use on a non-summing multi-deck weighing system, the range selected on a manual multiple range device, etc.

#### LG - 1.01 - PERMANENCE OF THE LETTERING (approval testing)

##### PURPOSE

This test is aimed at evaluating the permanence of the information to be marked on the device, or a major detachable element evaluated separately, in order to determine if it will withstand wear and cleaning. Markings are subjected to the following tests to simulate accelerated wear. The markings are then compared to a typical set of markings exhibiting various degrees of wear, graded from excessive unacceptable wear (1) to minimal effect (7).

##### APPLICATION

This test is to be applied to all mandatory markings including the manufacturer's name, the model and serial numbers, **Max**, **e** and **d**, the unit of measurement associated with weight indications (kg, lb), to other words or symbols associated with metrologically significant annunciators, etc.

##### TEST PROCEDURE

Attempts are made to remove the marked information, whether on a badge (plate) or on the device itself, using the following means:

**A.** Rub over one letter of the marking twenty (20) times using an ink eraser in the same manner and with the same force as one would normally exert while erasing an inscription written with a ballpoint pen.

**NOTE:** For consistency of application, the laboratories use Eberhard Faber ink eraser type # 101.

**B.** Clean (rub 20 times) with the following cleansers which are presumed to be readily available:

- 1 - Cleansing liquid and a damp cloth
- 2 - "Soft" household cleansing powder and a damp cloth
- 3 - Window cleansing fluids and a damp cloth

**NOTE:** For consistency of application, the laboratories use 409<sup>®</sup>, Bon Ami<sup>®</sup> and Windex<sup>®</sup> brands of products for the tests in parts B.1, B.2 and B.3 respectively.

##### INTERPRETATION OF RESULTS:

The information marked on the label is deemed to be permanent if, after the test, the label receives a grading of four (4) or higher (see the sample below).

Field Inspection Manual	Part: 3-STP	Section: 3	Page: 11 of 12
Non Automatic Weighing Devices	Issued: 2011-04-01	Revision Number: 3	

STP-3 MARKING

SAMPLES VARIOUS DEGREES OF WEAR

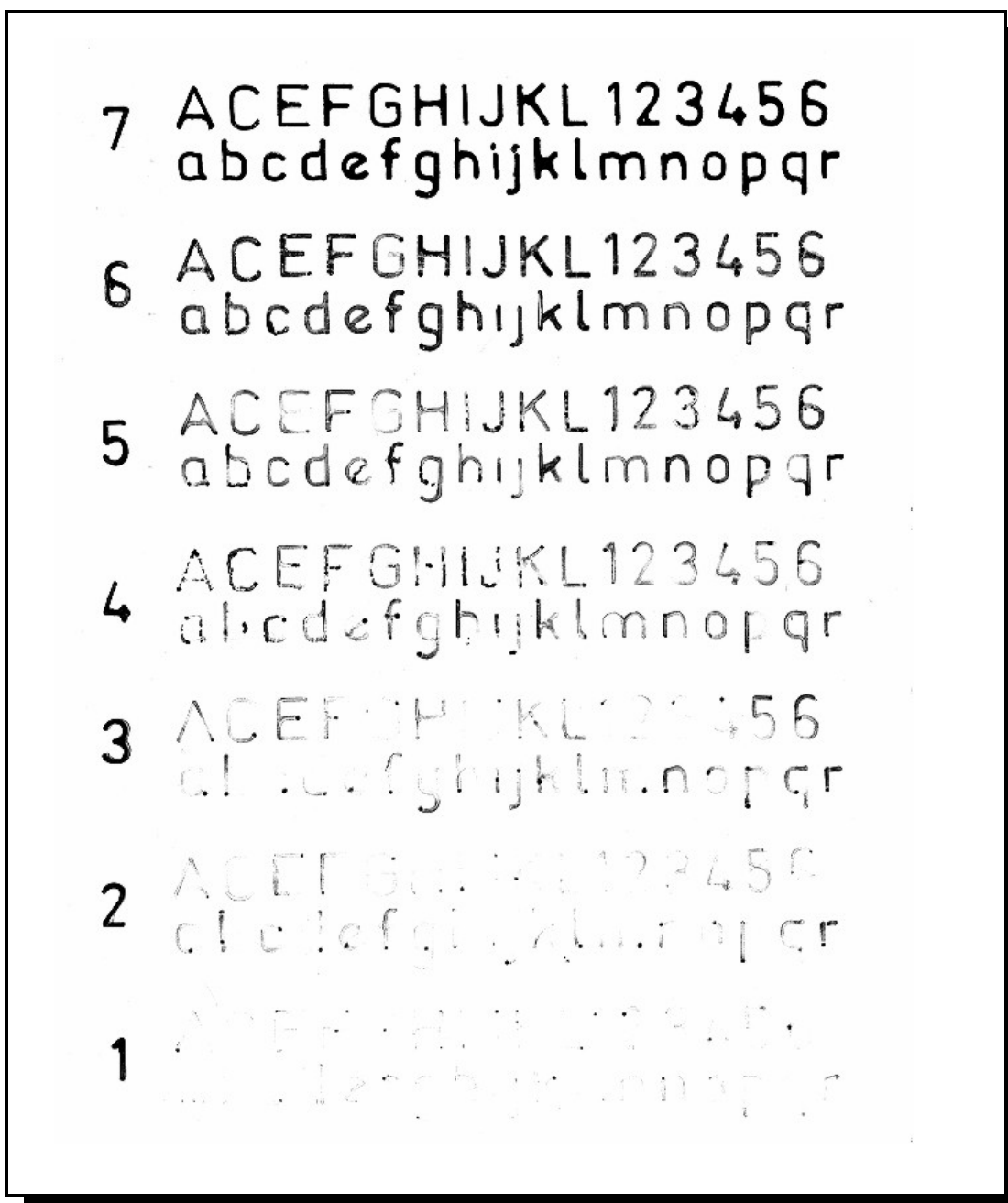

Field Inspection Manual	Part: 3-STP	Section: 3	Page: 12 of 12
Non Automatic Weighing Devices	Issued: 2011-04-01	Revision Number: 3	

### STP-3 MARKING

#### LG - 3.02 - PLATE, DECAL - PERMANENCE OF INSTALLATION AND DURABILITY OF THE MATERIAL

##### PURPOSE

To determine whether the label bearing identification markings (manufacturer's name, model and serial numbers, approval number, initial inspection marks or label) is permanently affixed to the device.

##### TEST PROCEDURE

An attempt is made to remove the specimen label(s) from the device by pulling it off or by prying off a metal badge that is only attached using adhesive. Any means of removal are allowed while a deliberate effort to conceal the removal is made.

##### INTERPRETATION OF RESULTS

An identification label is deemed to be permanently affixed to the device if it cannot be removed from the device and installed on another device without exhibiting readily observable signs of tampering. Acceptable indications of tampering are the destruction of the badge by tearing, permanent or extensive wrinkling, or the repeated exposure of the word "VOID" upon removal of the badge.

##### NOTES :

1. A plate that is riveted to the device is deemed to be permanently fastened if the part of the device to which it is attached is not readily removable.
2. For information such as lb/kg, motion annunciator, centre of zero annunciator, tare/net annunciator, Max, **e** and **d**, (if **d** is different from **e**), near the weight display, etc. (other than the identification markings: manufacturer's name, model, serial and approval numbers), a sticker that is sturdy and will not detach when subjected to the normal conditions of use of the device (heat, cold, humidity, cleaning) is acceptable. It does not have to be of the self-destructive type.

##### REVISION

- Rev.3 (January 2011)  
-updated marking requirements for Load Cells
- Rev.2 (January 2010)  
-marking requirements for Load Cells
- Rev.1 (Jan 2008)
- correct references to **e** and **d** as necessary.
  - correct reference to *Terms and Conditions for Metrological Software* in section 3.3.1
  - correct references to *Approval Evaluation Manual - Non Automatic Weighing Devices*.
  - remove reference "to the Public" from Direct Sales markings section 3.7
  - clarify multi-deck marking requirements in section 3.8
  - marking height is no longer a recommendation.
  - correct miscellaneous spelling errors and ensure consistent formatting.
  - clarify same units marking requirements for **Max** and **e/d**.
  - added marking requirement for Precious Metals & Precious Stones devices.
  - added auxiliary housing requirements.
  - correct references to *Specifications Relating to Non-automatic Weighing Devices (1998)*.
  - specify the minimum height of characters used for marking.

<b>Field Inspection Manual</b>	Part: <b>3-STP</b>	Section: <b>4</b>	Page: <b>1 of 4</b>
<b>Non Automatic Weighing Devices</b>	Issued: <b>2008-01-01</b>	Revision Number: <b>1</b>	

## **STP-4            SEALING**

### **REFERENCE**

Section 48 of the *Specifications Relating to Non-automatic Weighing Devices (1998)*.

### **GENERAL**

Electronic weighing devices must have provisions to the effect that a security seal must be broken, or an audit trail provided, before any adjustment affecting the performance of the device can be made. Only the metrological parameters: that can affect the measurement features, that have a significant potential for fraud, whose range extends beyond that appropriate for device compliance or the suitability of the equipment, shall be sealed.

Usually, adjustment and configuration parameters that require sealing are located in, or accessed through, the electronic indicator of a device. The suitability of the sealing means, for electronic indicators and complete devices, is evaluated by the Approval Services Laboratory (ASL) who ensure that devices have adequate provision for the application of security seals. Instructions and the method of sealing devices can therefore be found in their Notice of Approval.

Field inspectors must ensure that devices are sealed in the proper manner. For instance, junction boxes that contain means (potentiometers, rheostats, resistors, etc.) for "balancing" load cells must also be sealed. Some newer device types, however, are not sealable using physical seals. These devices are provided with event counters or electronic audit trails that record access to the calibration mode and changes to the configuration or calibration parameters. In such instances, the inspector records the numbers indicated by the event counters and obtains a print out of the events recorded by the electronic audit trail for further reference.

### **EXTRACTS FROM THE APPROVAL EVALUATION MANUAL - NON AUTOMATIC WEIGHING DEVICES**

Hereafter are the detailed marking requirements as extracted from the *Approval Evaluation Manual - Non Automatic Weighing Devices*. This extract is provided to ensure uniform and consistent application of the sealing requirements in the field. Note that the numbering of the following sections correspond to the numbering used in the *Approval Evaluation Manual - Non Automatic Weighing Devices*.

#### **4.1 - PHILOSOPHY FOR SEALING**

The judgement as to whether or not a method of access represents a "significant potential for fraud" and thus requires sealing, will be based upon the following philosophies.

4.1.1 - The need to seal specific features depends upon:

- a. The ease with which the feature or the selection of the feature can be used to facilitate fraud; and
- b. The likelihood that the use of the feature will result in fraud not being detected.

4.1.2 -Features or functions that are routinely used by the operator as part of device operation, such as the setting and maintaining of unit prices in price look-up codes, are not sealable parameters.

4.1.3 - If the selection of a parameter (or a set of parameters) would result in performance that would obviously be in error, such as the selection of parameters for different countries, then it is not necessary to seal the selection of these features.

<b>Field Inspection Manual</b>	Part: <b>3-STP</b>	Section: <b>4</b>	Page: <b>2 of 4</b>
<b>Non Automatic Weighing Devices</b>	Issued: <b>2008-01-01</b>	Revision Number: <b>1</b>	

## **STP-4 SEALING**

4.1.4 - If individual device characteristics are selectable from a "menu" or a series of programming steps, then access to the "programming mode" must be sealable.

4.1.5 - If a device must undergo a physical act, such as the cutting of a wire and physically repairing the cut to reactivate the parameter, it would be considered an acceptable way to select parameters without requiring a physical seal or an audit trail.

### **4.2 - SEALABLE PARAMETERS ON NON AUTOMATIC WEIGHING DEVICES**

The following examples of adjustments, parameters and features to be sealed are to be considered "typical" or "normal". The list is not intended to be all inclusive and any other parameters that may affect the metrological functions of a device must be sealed.

If listed parameters or other parameters which may affect the metrological function of a device are not to be sealed, the manufacturer must demonstrate that the parameter will not affect the metrological performance of the device.

### **SCALE FEATURES AND PARAMETERS**

#### **Typical Sealable Parameters**

Coarse zero

Span

Linearity correction points

Motion detection (on/off bandwidth)

Scale interval **d** (or location of the decimal point)

Number of scale intervals

Range of overcapacity

Manual weight entries (on/off)

AZTM (on/off and range of a single step)

Zero and AZTM total range (if the range can be set for more than 4% and if this increases the weighing capacity)

Filter (number of samples averaged for weight readings)

Filter (averaging time for weight indications)

Units of measurement (if not displayed or printed on the primary register)

#### **Typical Features or Parameters that are Not Required to be Sealed**

Product codes

Commodity unit prices

Zero and AZTM total range (if the range can be set for more than 4% but this **does not** increase the weighing capacity)

Display update rate

Selection of tare feature operation (keyboard push button or automatic tare (on/off))

Weigh-in/weigh-out operation (on/off)

<b>Field Inspection Manual</b>	Part: <b>3-STP</b>	Section: <b>4</b>	Page: <b>3 of 4</b>
<b>Non Automatic Weighing Devices</b>	Issued: <b>2008-01-01</b>	Revision Number: <b>1</b>	

**STP-4            SEALING**

**4.3 OTHER MECHANISMS REQUIRING SEALING**

4.3.1 - Junction boxes that have adjustment parameters (potentiometers, rheostats, resistors or software configuration, etc.) must have provisions for applying security seals.

4.3.2 - In the case of a complete scale consisting of an electronic indicator and a load receiving element incorporating a junction box or load cells that have built-in calibration/configuration capabilities, and for which the parameters can be changed "remotely" through the indicator keyboard, there must be provisions to seal load cell cables to the indicator and junction box.

4.3.3 - If the device is equipped with an automatic or semi-automatic calibration mechanism, the mechanism must be inside the device and there must be provisions to apply security seals so that neither the mechanism nor the calibration process can be altered.

**NOTE: Automatic and Semi-Automatic Calibration Mechanism**

An automatic or semi-automatic calibration mechanism is allowed provided the calibration mechanism is internal to the device and neither the mechanism nor the process can be manipulated in a fraudulent manner.

Using the calibration mechanism, attempt to calibrate the device when the device is off level, when there is a load on the platter, and when the weight indication is in motion. Also attempt to put a small load on the platter while the internal mechanism performs a calibration.

No erroneous calibration may result from such manipulation.

**4.4 - PHYSICAL SEALS**

Physical seals comprise "lead and wire" seals, pressure sensitive seals, etc. They may be used to seal certain device categories, features and mechanisms (see section 4.3).

4.4.1 - Seals must be readily accessible and observable. Devices must be sealable in a manner that does not require disassembly or moving of the device to gain access to the adjustments. However, removing a protective cover plate to access a junction box is acceptable. The removal of a cover plate must be simple and not require excessive effort or the use of special tools.

4.4.2 - On small devices the means of sealing may be under the platter, if the platter can be lifted easily, under the scale or at the back of the scale if the scale is designed so that it can be turned upside down without damage to remove or apply security seals. When a "lead and wire" seal is located under the platform, there must be ample clearance to eliminate the possibility of interference between the seal and the platform.

4.4.3 - When two bolts are used for a "lead and wire" seal, it must be impossible to remove either bolt without breaking the seal. A free standing bolt (a bolt which passes through a panel and is fixed in place with a nut on the opposite side of the panel) is not acceptable.

<b>Field Inspection Manual</b>	Part: <b>3-STP</b>	Section: <b>4</b>	Page: <b>4 of 4</b>
<b>Non Automatic Weighing Devices</b>	Issued: <b>2008-01-01</b>	Revision Number: <b>1</b>	

## STP-4 SEALING

4.4.4 - Pressure sensitive seals are acceptable under certain conditions. If they cover a hole (e.g., through which a "calibration enable" switch would be activated) the hole must be covered with a suitable rigid plug. The seal must be fully supported and not so as to leave cavities or air pockets under the seal. Cavities and air pockets are weak points that could cause the seal to be easily damaged (see the illustration below).

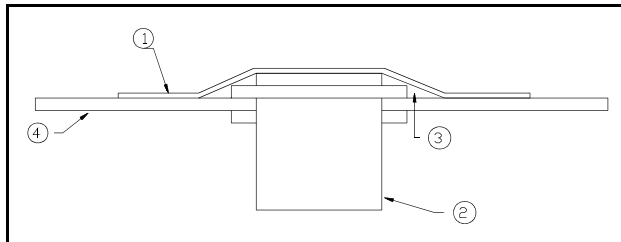

- (1) Pressure sensitive (paper) seal
- (2) Keylock
- (3) Air pocket (void space)
- (4) Casing

4.4.5 - A pressure sensitive security seal is not suitable in an adverse environment (rain, cold, washdown, etc.).

## 4.5 - SEALING ELECTRONIC DEVICES

Electronic devices may be "sealed" by means of an audit trail. The audit trail must comply with the minimum requirements contained in the *Terms and Conditions for the Approval of Metrological Software*. For devices sealed by means of an audit trail, the inspector should refer to the Notice of Approval for the device in question.

The terms used in the Notice of Approval are defined in the *Terms and Conditions for the Approval of Metrological Audit Trail* that can be found on the Measurement Canada web site at <http://mc.ic.gc.ca>.

## REVISION

Rev 1.

- change references from 'Draft Specifications' to 'Terms and Conditions' as appropriate.
- change reference to Approval Evaluation Manual - Non Automatic Weighing Devices
- correct references to *Specifications Relating to Non-automatic Weighing Devices (1998)*.

Field Inspection Manual	Part: 3-STP	Section: 5	Page: 1 of 1
Non Automatic Weighing Devices	Issued: 2004-03-01	Revision Number: Original	

## STP-5 VISUAL EXAMINATION OF THE INDICATING ELEMENT

### REFERENCE

Sections 3 and 30 to 38 of the Non Automatic Weighing Devices Specifications.

Indicating elements, either approved separately or as part of complete weighing devices, are evaluated by the Approval Service Laboratory (ASL) for compliance with the specifications.

The inspectors role in performing the visual examination of an indicating element is to ensure that it is approved, the value of the scale interval has been selected/set in accordance with the specifications or as specified in the Notice of Approval (NOA); that names, symbols and defining words are legible; and that the parts of mechanical indicating elements are in good working condition.

### VALUES OF “d” and “e”

The inspector must ensure that the value of “d” has been selected in accordance with the requirements prescribed by sections 3, 36, 37 and 38 of the specifications. The inspector must also ensure that the values of “d” and “e” meet the limitations laid out in the Notice of Approval. Namely, the maximum number of scale intervals ( $n_{max}$ ) must not exceed the number authorized by the Notice(s) of Approval and the value of “e” selected must not be smaller than the minimum value ( $e_{min}$ ) authorized by the NOA for the weighing element.

The inspector ensures that the unit(s) of measurement selected is (are) a legal unit of measurement and that the scale was approved for that unit.

Except for weight classifiers, the inspector must ensure that the value of the scale interval indicated and printed are the same.

### LEGIBLE SYMBOLS AND DEFINING WORDS

The inspector ensures that defining words, symbols or abbreviations for weight and price values, and metrologically significant annunciators, are legible and that the display segments are in good condition.

### BEAM OR DIAL SCALES

The inspector must ensure that graduation lines are legible and allow for accurate weight readings. The inspector also ensures that the indicating component (pointer) is firmly attached, can travel freely (does not touch the chart) and is positioned (relative to the beam or chart) to reduce the effects of parallax to a minimum.

The inspector ensures that the indicating beam is secured in place; that parts of the poise are not loose; that adjusting material in the poise is enclosed securely, firmly fixed in position and not in contact with the beam; and that the pawl (if any) holds the poise firmly in position without any appreciable movement.

The inspector ensures that the balance ball or other mechanical zero setting means is firmly held in position.

### REVISION

Original document

Field Inspection Manual	Part: 3-STP	Section: 6	Page: 1 of 5
Non Automatic Weighing Devices	Issued: 2008-01-01	Revision Number: 1	

## STP-6 VISUAL EXAMINATION OF THE PRINTED TICKET

### REFERENCE

Sections 30 to 38, 66 and 67 of the *Specifications Relating to Non-automatic Weighing Devices (1998)*.

### PURPOSE

The recording element (printer) of a device shall be appropriate and compatible with the device. Recorded representations must be clear, definite, accurate and easily readable. The interfacing of a printer to a device must not cause any alteration or degradation of the metrological characteristics of the device and must not facilitate the perpetration of fraud.

### THE INSPECTOR ENSURES THAT THE FOLLOWING REQUIREMENTS ARE MET.

- All recorded values shall be permanent, legible and printed in digital format.
- The device must indicate and print weight values in the same unit of measurement.
- The value of **d** printed and the value of **d** displayed must be the same (except for postal scales and weight classifiers).
- The value of **d** printed may be larger than the value of **d** displayed by a weight classifier provided that the measurement, the weight classification and the pricing are accurately determined. Tests must be performed at the turning points of price ranges (see STP-17).
- Except for weight classifiers, a printer must record the same value and number of decimal places as indicated on the display.

### CLARIFICATION

A digital indicator may display weight values in 0.005 kg and 0.01 lb scale intervals. The printer must therefore record weight values to 0.005 kg in metric and 0.01 lb when measuring in pounds. It may not record weight values to 0.010 lb.

All recorded weight values, such as gross, tare, net, inbound and outbound weights, shall be clearly identified using acceptable words, abbreviations or symbols (see Appendix-A). However, if only one weight is printed, it does not have to be identified as the "net" weight.

If the unit of measurement of the device can be externally selected by the user (lb/kg switch), the printer must record the proper unit of measurement along with the weight values. Preprinted tickets stating the weight unit are acceptable for indicators capable of displaying one weight unit only or which have an internal lb/kg switch.

Computation must be in mathematical agreement (gross weight - tare weight = net weight; unit price x net weight = total price, rounded to the nearest cent).

### PRICE COMPUTING DEVICES

Unit prices must be printed when total prices are shown and both have to be clearly identified as the unit price and the total price.

Field Inspection Manual	Part: <b>3-STP</b>	Section: <b>6</b>	Page: <b>2 of 5</b>
Non Automatic Weighing Devices	Issued: <b>2008-01-01</b>	Revision Number: <b>1</b>	

## **STP-6 VISUAL EXAMINATION OF THE PRINTED TICKET**

### **POINT OF SALE (POS) WEIGHING SYSTEMS**

The cash register tape must provide the information required by section 67 of the *Specifications Relating to Non-automatic Weighing Devices (1998)*. That is, the net weight, the price per unit, the computed price, and the appropriate identification code or product name. Furthermore, in order to standardize content and layout, as well as adding clarity to POS receipts, the rules and examples found at the end of this section must be followed. Please note that the identification code/product name has been left out of the first example for clarity; this information is however required on actual POS receipts.

A POS system may display the "Gross" weight on the scale display and the "Net" weight on the cash register display; however, it must print the "Net" weight on the cash register tape. The scale of a POS system is not required to display the net weight nor provide an indication that a tare value has been entered.

Training mode is no longer required on POS systems.

Field Inspection Manual	Part: <b>3-STP</b>	Section: <b>6</b>	Page: <b>3 of 5</b>
Non Automatic Weighing Devices	Issued: <b>2008-01-01</b>	Revision Number: <b>1</b>	

**STP-6 VISUAL EXAMINATION OF THE PRINTED TICKET**

**POINT OF SALE (POS) RECEIPTS**

I	II	III	IV	V
<b>1</b>	<b>kg or lb</b>	<b>@</b>	<b>\$</b>	<b>12.49</b>
<p>Must be identical to the scale display (interval size and capacity limitation)</p> <p>Must print a zero before the decimal point if the weight is less than 1 kg or lb</p> <p>A period or comma can be used as the decimal point</p>	<p>Must be lowercase letters</p> <p>The use of "lbs" or "#", as the symbol for pounds, is not acceptable</p>	<p>Can be replaced by: "at" ("à" in French)</p>	<p>Must be placed before or after the value in column V</p>	<p>Must be two digits after the decimal point</p> <p>Must be preceded by a zero, before the decimal point, if the value is less than one</p> <p>A period or comma can be used as the decimal point but must remain consistent throughout the receipt</p>

VI	VII	VIII	IX
<b>/</b>	<b>kg or lb</b>	<b>\$</b>	<b>12.49</b>
<p>Can be replaced by: "per" ("par" in French)</p>	<p>Must be lowercase letters</p> <p>The use of "lbs" or "#", as the symbol for pounds, is not acceptable</p>	<p>Required if there is only 1 space between columns VII and VIII</p> <p>Optional if there are two or more spaces between columns VII and VIII</p> <p>Can be placed before or after the value in column IX</p>	<p>Must be two digits after the decimal point</p> <p>Must be preceded by a zero, before the decimal point, if the value is less than one</p> <p>A period or comma can be used as the decimal point but must remain consistent throughout the receipt.</p>

\* **Note:** Product identification code/name is also required.

Field Inspection Manual	Part: 3-STP	Section: 6	Page: 4 of 5
Non Automatic Weighing Devices	Issued: 2008-01-01	Revision Number: 1	

**STP-6 VISUAL EXAMINATION OF THE PRINTED TICKET**

**SPACING:**

- A space is required between columns I and II (due to the use of "lb")
- At least 1 space is required between columns II and III
- At least 1 space is required between columns III and IV
- No space between columns IV and V, regardless of whether the "\$" is placed before or after the "12.49"
- A space between columns V and VI is optional if the slash "/" is used. If the word "per" ("par" in French) is used then a space is required.
- A space between columns VI and VII is optional if the slash "/" is used. If the word "per" ("par" in French) is used then a space is required
- At least 1 space is required between columns VII and VIII
- No space between columns VIII and IX, regardless of whether the "\$" is placed before or after the "12.49"

**SAMPLE RECEIPTS:**

1234 Mansfeld Montréal, Québec (555) 555-5555	
Bananas	
0.895 kg @ \$2.49/kg	\$2.23
Bulk coffee	
1.275 kg @ \$16.49/kg	\$21.02
Tomatoes	
0.645 kg @ \$0.89/kg	\$0.57
Total	\$23.82

Michael's Supermarket 1234 Mansfeld Montréal, Québec (555) 555-5555	
# 1742	
0.895 kg @ 2.49\$ per kg	2.23\$
# 6795	
1.275 kg @ 16.49\$ per kg	21.02\$
# 0125	
0.645 kg @ 0.89\$ per kg	0.57\$
Total	23.82\$

Michael's Supermarket 1234 Mansfeld Montréal, Québec (555) 555-5555	
Bananas	
0,895 kg @ \$2,49 per kg	\$2,23
Bulk coffee	
1,275 kg @ \$16,49 per kg	\$21,02
Total	\$23,25

Michael's Supermarket 1234 Mansfeld Montréal, Québec (555) 555-5555	
0,895 kg at \$2,49 / kg	2,23
Bananas	
1,275 kg at \$16,49 / kg	21,02
Bulk coffee	
0,645 kg at \$0,89 / kg	0,57
Tomatoes	
Total cost	23,82

Field Inspection Manual	Part: 3-STP	Section: 6	Page: 5 of 5
Non Automatic Weighing Devices	Issued: 2008-01-01	Revision Number: 1	

### STP-6 VISUAL EXAMINATION OF THE PRINTED TICKET

Michael's Supermarket 1234 Mansfeld Montréal, Québec (555) 555-5555		
<u>Item</u>	<u>Unit price</u>	<u>Total price</u>
Bananas		
0.895 kg	\$2.49/kg	\$2.23
Bulk coffee		
1.275 kg	\$16.49/kg	\$21.02
Tomatoes		
0.645 kg	\$0.89/kg	\$0.57
Tota		\$23.82

Michael's Supermarket 1234 Mansfeld Montréal, Québec (555) 555-5555	
Product # 1742	
0.895 kg	
@ \$2.49/kg	2.23
Product # 6795	
1.275 kg	
@ \$16.49/kg	21.02
Total	23.25

### WEIGHT CLASSIFIERS

In the case of weight classifiers, it is acceptable if the printed ticket provides the weight only or the weight along with the total price to be paid. The unit price is not necessary since the total price to be paid is determined on the basis of weight ranges within the device's weighing capacity rather than on the basis of a price per unit.

### DIMENSIONAL WEIGHT

This section does not apply to the use of Multi-Dimensional Measuring Machine (MDMD) - the Specifications Relating to Multi-Dimensional Measuring Machines would apply. This section applies to all other Dimensional Weight applications. This practice may be referred to as *Dimensional Weight at Retail*.

When Dimensional Weight statements are made on a receipt, the receipt must include the actual weight and actual hexahedronal dimensions of the object. In addition, the Dimensional Weight (Density) factor must be provided on the receipt. The formula and rate classifications must be posted or otherwise provided to the customer upon request.

### REVISION

Rev1.

- remove POS definition from this section. See IPO 2.2 (POS).
- add *Dimensional Weight at Retail* requirements.
- correct references to *Specifications Relating to Non-automatic Weighing Devices (1998)*. Original Document

<b>Field Inspection Manual</b>	Part: <b>3-STP</b>	Section: <b>7</b>	Page: <b>1 of 6</b>
<b>Non Automatic Weighing Devices</b>	Issued: <b>2009-02-01</b>	Revision Number: <b>3</b>	

## **STP-7 INSTALLATION AND LOCATION OF THE DEVICE**

### **REFERENCE**

Section 33 of the *Weights and Measures Regulations*, sections 55 to 60, 63 & 64 of the *Specifications Relating to Non-automatic Weighing Devices (1998)*.

Devices must be installed to allow for the accurate measurement of commodities and so that they remain stable and accurate over time under normal conditions of use. Operators and customers, if applicable, must be able to read the device indications and must be able to observe the load receiving element during weighing operations. Devices must be located and installed so that the necessary standards and testing material can be brought to the devices, and can be inspected and sealed. In most cases, the suitability of installation and location will be determined when the initial inspection is performed.

### **MANUFACTURERS INSTRUCTIONS**

In the Specifications, there are only a few broad requirements pertaining to the installation of weighing devices. There exist numerous device designs, capacities and types for all kinds of applications on the market. The minimum installation requirements for a particular device type depend upon its design, construction and intended use. Establishing those minimum requirements is, to a certain extent, part of the design process. We rely on device manufacturers to provide, when necessary, specific instructions for the installation and use of the devices they build.

Section 55 of the *Specifications Relating to Non-automatic Weighing Devices (1998)* provides the necessary authority to require that devices are installed in accordance with manufacturers instructions, plans, blue prints, etc.

### **INSTALLATION PARAMETERS IN NOTICES OF APPROVAL (NoA)**

When necessary, the NoA may also provide minimum requirements or restrictions for installation and use of devices.

### **SUPPORTS AND FOUNDATIONS (COMPUTING, COUNTER, BENCH AND PLATFORM SCALES)**

The table, bench or counter that supports the scale must be stable and strong enough to withstand loads without noticeable movement and the supporting surface must be relatively leveled, so as to ensure accurate measurement. If binding may be considered problematic (e.g. device is installed in a counter well, etc.), the device shall be securely fastened to the counter or otherwise restrained from moving from its intended location through the use of retainers, etc.

### **SUPPORTS AND FOUNDATIONS (STEELYARD SCALES, WALL MOUNTED)**

Mounting and holding means of wall or post mounted steelyard scales must be such to minimize deflections that could affect the accuracy of measurement under load. Holding brackets must be installed plumb, so that when the device is pivoted around the bracket while under load, measurement accuracy is not affected. If the holding system does not appear adequate, inspectors may perform the following tests:

- Set the device to zero, and change its position. The zero reference should not shift (the beam moves up or down). This test can be done with the device loaded. Ensure that the weight indication does not change.

Field Inspection Manual	Part: <b>3-STP</b>	Section: <b>7</b>	Page: <b>2 of 6</b>
Non Automatic Weighing Devices	Issued: <b>2009-02-01</b>	Revision Number: <b>3</b>	

## STP-7 INSTALLATION AND LOCATION OF THE DEVICE

### SUPPORTS AND FOUNDATIONS (HOPPER & TANK SCALES)

Foundations must be of such strength to prevent deflections and vibrations that would adversely affect measurement.

Test weight lifting mechanisms (automatic or semi-automatic), if any, must be installed and must operate in a way that prevents inadvertent measurement errors. For instance, the lifting mechanism must be installed with safeguards or interlocks that prevent weighings (trade transactions) unless the mechanism is in its off position and that the test weights are in free position. Provision must be made to allow for applying test weights during testing of the device. Test weight hooks, pans, platforms, etc. must be securely attached to the device and able to safely withstand the intended test load.

### SUPPORTS AND FOUNDATIONS (VEHICLE SCALES AND RAILWAY SCALES)

#### Generalities:

#### Temporary Installation

Vehicle Scales installations are generally categorized as either Permanent or Temporary. Temporary installations are not desirable due to their less than ideal installations. Nevertheless, it is recognized that there may be legitimate need for temporary installations in some cases. Temporary installations of self contained **Portable Vehicle Scales** are subject to the following requirements:

Temporary Installations of Portable Vehicle Scales will not generally be permitted at permanent business locations. If a company is conducting their primary business from the location, then a permanent installation will be required. Written requests for short term (less than 1 year) temporary installations will only be considered at permanent business locations if the company can demonstrate a legitimate need, such as to fulfill a short term contract, etc. Legitimate temporary installation applications include road construction, temporary gravel pits, short term logging contracts or similar applications.

Portable Vehicle Scales installed in a temporary manner may remain at a single location for no more than one year. If the device is to remain beyond this time period, it must be permanently installed and meet all of the installation and performance criteria. If a Temporary Installation is required beyond this time frame, extensions must be requested in writing, from the nearest Measurement Canada Office. Extension may be granted beyond one year if the owner is able to demonstrate a legitimate need and agrees to provide evidence of annual recalibration using certified test standards.

A temporary installation must be kept level and must be able to withstand loads up to the device capacity without movement or deflections. This requirement is applicable at all times while the device in use. If ground/weather conditions preclude meeting this requirement, the device must not be used (i.e. during Spring Break Up, excess movement due to frost, etc.). Shims and other means of height adjustment shall be made of any suitable material that resists compression at least as well as the main support structure (e.g. steel plate), and shall fill the entire void area under the lever stands or load cell bases to ensure that the scale remains stable and level under normal conditions of use of the scale.

Field Inspection Manual	Part: 3-STP	Section: 7	Page: 3 of 6
Non Automatic Weighing Devices	Issued: 2009-02-01	Revision Number: 3	

## STP-7 INSTALLATION AND LOCATION OF THE DEVICE

### Permanent Installation

A permanent installation must be supported by a foundation or a pit the base of which is below the frost-line (information to be obtained from the local Building Code) or that rests on stable substrata such as bedrock. A floating slab of reinforced construction (concrete) may also be appropriate when the scale components are kept aligned and level. Shims and any other means of heights or level adjustment shall be clean, smooth and made entirely of steel or other material of equivalent strength, and if not grouted, shall fill the entire void under the lever stands or load cell bases to ensure that the scale remains stable and level under normal conditions of use of the scale. When a void remains under the lever stands or load cell bases, the lever stands or load cell bases must be grouted. Grout must fill the entire void under the lever stands or load cell bases.

For Vehicle Scale systems installed in the winter months, it may not always be feasible to provide either permanent foundations or approaches due to ground frost. In these cases, the Regional Gravimetric Specialist or appropriate District Manager must be contacted for permission to delay these two requirements until spring thaw. This permission will only be granted if the ground frost provides an adequate and stable support for the scale and approaches. In addition, the Specialist or District Manager may require a written letter of intent to meet these two conditions as soon as the ground has thawed sufficiently. In no case shall the system continue to be used, after the ground has thawed, until the appropriate modifications have been completed.

### Access to Understructure of Vehicle and Railroad Scales

Understructure of weighing elements of vehicle and railroad scales must be easily accessible to permit the visual examination of the main components (load cells, levers, junction boxes). Where a pit is required for the installation of a scale, that pit must be provided with an entrance that allows inspection of the area beneath the weighbridge. **Inspectors should note that access to confined spaces is a potentially dangerous practice and company policy must be followed.** See also Measurement Canada - Health & Safety Programs, Confined Spaces document.

Field Inspection Manual	Part: 3-STP	Section: 7	Page: 4 of 6
Non Automatic Weighing Devices	Issued: 2009-02-01	Revision Number: 3	

## STP-7 INSTALLATION AND LOCATION OF THE DEVICE

### Approach and Exit Ramps of Vehicle Scales]

Sections 63 and 64 of the *Specifications Relating to Non-automatic Weighing Devices (1998)* provides the minimum requirements for approach and exit ramps of vehicle scales.

NAWDS section 63.1(c) and section 64, require approach and exit ramps to be smooth, level and in the same plane as the weighbridge. A ramp shall be deemed to be level if the slope is no greater than 2% (2 cm/m) longitudinally. Any crowning of the approach must be flared to meet the weighbridge smoothly and may not exceed 2% slope. This is to allow for adequate drainage and to account for slight variations in the ramp. The slope shall be measured over a minimum length of 1.0 metre.

A vehicle scale need not have both an entry and exit ramp where installation particulars allow for only a single ramp. Appropriate conditions of construction apply to all available ramps.

Loading of a vehicle scale shall not normally be permitted across the side of the scale. In the case of a flush mount built in scale, appropriate barriers may be required, depending on installations specifics, to prevent improper loading of the scale.

### VISIBILITY OF INDICATING ELEMENTS

Devices that are used in "direct sale" applications, must be positioned so that the indications may be easily read by the customer.

### Computing Scales and POS Systems in Retail Stores, and Other Similar Applications

Computing scales are not required, under the specifications, to have an integrated customer's display. If the device can be positioned so that both the operator and customer can easily read the indications, the requirement is met. If it can not be accomplished, a secondary indicating element that duplicates the primary indications must be provided. In the case of a POS scale, the secondary indicating element need not be approved if it is fully compatible with the scale, is properly marked and has no internal metrological functions. Providing a button to access an external zero activating means is not considered a metrological function.

### Vehicle Scales

Measurement Canada Bulletin M-24 provides additional requirements for secondary indicators for vehicle scale installations.

### VISIBILITY OF THE WEIGHING ELEMENT

In "direct sale" applications, customers must be able to observe the weighing element of the device from the indicator's reading position.

<b>Field Inspection Manual</b>	Part: <b>3-STP</b>	Section: <b>7</b>	Page: <b>5 of 6</b>
<b>Non Automatic Weighing Devices</b>	Issued: <b>2009-02-01</b>	Revision Number: <b>3</b>	

## **STP-7 INSTALLATION AND LOCATION OF THE DEVICE**

Operators must be able to observe the weighing element from the indicator's reading position. If this is impossible, means such as a camera must be provided so that the operator can observe the weighing element. The purpose of this requirement is to ensure that the operator will be able to detect any activities around or on the load receiving element liable to cause erroneous measurement. For instance, the operator must be able to observe the weighing element of a vehicle scale to ensure that, during the weighing process, the vehicle is entirely supported by the scale deck, that the driver remains in or out the vehicle, that no one is walking across the weighing element, etc. This requirement does not apply to installations where the load receiving element is not liable to be disturbed or the material to be weighed altered during the weighing process.

### **ACCESS AND MEANS TO APPLY STANDARDS**

All scales including livestock, vehicle and vehicle/railroad combination scales must be located and installed so that test weights in sufficient numbers and material for strain tests can be brought to the device for inspection purposes.

Hopper and tank scales must be provided with the appropriate accessories (i.e. suspending equipment, hooks, etc.) to allow for the safe application of the required amount of test standards necessary for the inspection.

### **REVISION**

#### Rev. 3

- added clarification of 'level' requirements for vehicle scale ramps.

#### Rev. 2 (2008-01-01)

- added requirements for Temporary Installation of Portable Vehicle Scales.
- clarified grout/shim requirements for vehicle scale installations.
- clarified approach requirements for vehicle scale installations.
- added confined space entry criteria for entering scale pits.
- removal of obsolete terminology ('contractor scale').
- clarified wording & intent in several sections.
- added secondary indicator criteria for POS as per GSC 2006-04(f).
- expanded requirement for access to scale and necessary rigging for application of standards.
- removal of 'to the public' from direct sales references.
- added securing of counter scales when appropriate.
- added weight receiving requirements for tank/hopper scales.

<b>Field Inspection Manual</b>	Part: <b>3-STP</b>	Section: <b>7</b>	Page: <b>6 of 6</b>
<b>Non Automatic Weighing Devices</b>	Issued: <b>2009-02-01</b>	Revision Number: <b>3</b>	

**STP-7 INSTALLATION AND LOCATION OF THE DEVICE**

- correct references to *Specifications Relating to Non-automatic Weighing Devices (1998)*.

Rev. 1

- added section for Winter Installation (approaches / foundation).

Field Inspection Manual	Part: 3-STP	Section: 8	Page: 1 of 5
Non Automatic Weighing Devices	Issued: 2010-01-01	Revision Number: 2	

## STP-8 ZERO SETTING MECHANISMS

### REFERENCE

Sections 40 to 44 of the Specifications Relating to Non-automatic Weighing Devices (1998).

### PURPOSE

There are several requirements that establish the proper operation of zero setting mechanisms to ensure accuracy and to prevent the perpetration of fraud or inadvertent measurement errors. These requirements depend upon the type of zero setting mechanisms and applications. These requirements are found in sections 40 to 44 of the Non Automatic Weighing Devices Specifications and in the Laboratory Manual.

The Laboratory performs a complete evaluation of the zero setting mechanisms at the time of approval. Configuration parameters and limitations concerning zero setting mechanisms are indicated in NOAs. Field inspectors must ensure that the zero setting mechanisms are configured or set in accordance with those parameters and limits, particularly when the device is initially inspected. Consult the NOA for limits & restrictions on the use of the various zero setting mechanisms.

### DEFINITIONS

**Automatic Zero-Setting Mechanism (AZSM):** mechanism for setting the indication to zero automatically without the intervention of an operator. This feature is restricted for use only when the indication is below zero and has remained stable for at least 5 seconds.

**Automatic Zero-Tracking Mechanism (AZTM):** mechanism for maintaining the zero indication within certain limits automatically.

**Initial Zero-Setting Mechanism (IZSM):** mechanism for setting the indication to zero automatically at the time the device is switched / powered on and before it is ready to use.

**Manual Zero-Setting Mechanism (MZSM):** mechanism for setting the indication to zero by the operator.

**Semi Automatic Zero-Setting Mechanism (SAZSM):** mechanism for setting the indication to zero automatically following a manual command (Push-button Zero).

### PROCEDURES

#### AUTOMATIC ZERO-SETTING MECHANISM (AZSM)

AZSM is a feature to automatically re-zero a scale which is not displaying a zero indication. AZSM must only operate when in the Gross mode. AZSM may only operate when the scale is off zero in a negative direction (weight is below zero) and must be a sealable parameter. The use of AZSM is not appropriate in all instances and may be prohibited in the Notice of Approval (NOA) or on the inspection certificate. In these cases, the AZSM must be disabled and sealed to ensure it is not used. AZSM is not appropriate for use with any device that utilizes a removable LRE as part of normal operation (e.g. candy scoop).

Field Inspection Manual	Part: 3-STP	Section: 8	Page: 2 of 5
Non Automatic Weighing Devices	Issued: 2010-01-01	Revision Number: 2	

### STP-8 ZERO SETTING MECHANISMS

- Check that any means to enable/disable the AZSM can be disabled and that the feature is sealable.
- Ensure that the use of AZSM is appropriate for the application.
- AZSM must only operate when the device is in Gross mode.
- The NOA will identify devices with AZSM features that have been evaluated and approved for use in trade. If AZSM is not mentioned in the NOA, it may still be used subject to suitability of use and performance testing.

In order to determine if a device has AZSM and if the feature is operating correctly, perform the following test:

#### Procedure (negative direction)

- Zero the device
- Place a 5d load on the device.
- Zero the device using the Semi-Automatic Zero Setting Mechanism (SAZSM)
- Remove the load and note the indication (-5d, ----, error, etc.)
- Without adjusting the balance condition of the device, observe the scale indications after one minute (or the specified AZSM activation time if known).
- If the device has returned to zero indication it is deemed to have an automatic zero setting feature which is functioning in the negative direction.

#### Interpretation of results

The device may be equipped with AZSM operational in the negative direction. This feature must not operate unless the load is stable for at least 5 seconds. The use of AZSM is not suitable for all applications.

If the device has an AZSM which operates in the negative direction, then the inspector must ensure that this feature is not operational in the positive direction. The device AZSM must not be set or configured to re-zero a positive weight value (greater than 0 indication). Perform the following test:

#### Procedure (positive direction)

Zero the device

- Place a 5d load on the device. Without adjusting the balance condition of the device, observe the scale indications after one minute (or the specified AZSM activation time if known).

If the device has returned to zero indication it is deemed to have an automatic zero setting feature which is functioning in the positive direction.

#### Interpretation of results

The device may not be equipped with AZSM operational in the positive direction. This feature must be disabled and sealed out or the device non-complied.

Field Inspection Manual	Part: 3-STP	Section: 8	Page: 3 of 5
Non Automatic Weighing Devices	Issued: 2010-01-01	Revision Number: 2	

## STP-8 ZERO SETTING MECHANISMS

### AUTOMATIC ZERO-TRACKING MECHANISM (AZTM)

The device AZTM must not be set or configured to re-zero a weight value in excess of 0.6e in a single operation. Perform the following test:

#### Procedure

- Zero the device
- Place a known test load "A" equal to or greater than e (e.g: 10e), plus a load "B" equal to 0.7e on the device load receiving element.
- Remove the known test load "A", wait for at least 10 seconds to see if the device will automatically re-zero test load "B".

#### Interpretation of results

- The device is deemed to comply with the requirement if it does not automatically re-zero loads in excess of 0.6e. Re-zeroing of any load less than or equal to 0.6e is acceptable.

### INITIAL ZERO-SETTING MECHANISM (IZSM)

This test is performed at the time the device is initially inspected only. This test is to determine if the value that the IZSM can zero exceeds 20% **Max**. Perform the following test:

#### Procedure (Complete electronic scale)

- Remove the platter in order to reach the lowest point of the IZSM range;
- Remove power from device and wait at least 10 seconds. Restore power to the device to activate the IZSM  
(Note: on some devices, it is sufficient to switch it off and on, while others will require disconnection from the power source. In either case, the 10 seconds allows time for the device to completely shut down.);
- Put the platter back on the scale and note the indication; if necessary, add weights to reach 20% **Max**;
- Remove power from the device and wait at least 10 seconds. Restore power to the device to activate the IZSM; if the device resets to zero, add a load of approximately 5% **Max** to the platter.
- Remove power from the device and wait at least 10 seconds. Restore power to the device; if the IZSM range is limited to 20% **Max**, the device will not reset to zero.

#### Interpretation of results

The maximum IZSM range of a device must not be set for more than 20% **Max** unless otherwise indicated in the NOA.

A device comprised of an electronic indicating element and a weighing element which were approved separately, may not have the IZSM range set for more than 20% **Max**.

### MANUAL ZERO-SETTING MECHANISM (MZSM)

If the balance at zero-load is achieved by the addition of supplementary material, the material must be enclosed in a cavity covered with a cap (affixed with screws, etc.) so that it cannot be readily removed or altered and so that it cannot shift position in such a way that the balance condition of the device is affected during the weighing operation.

Field Inspection Manual	Part: 3-STP	Section: 8	Page: 4 of 5
Non Automatic Weighing Devices	Issued: 2010-01-01	Revision Number: 2	

## STP-8 ZERO SETTING MECHANISMS

If a device is provided with a balance ball and a captive screw or nut arrangement, the maximum effect must not exceed 4e per revolution, and means must be provided to ensure sufficient friction to prevent a zero change during weighing operation.

A device intended for direct sales may not be fitted with a MZSM unless operated only with a detachable tool .

The total range of zero setting (positive and negative portion) may not exceed 4% Max unless the gross load that can be weighed is not increased beyond the device capacity limit.

### SEMI AUTOMATIC ZERO-SETTING MECHANISM (SAZSM)

The total zero-setting range (negative + positive) may be set to exceed 4% **Max** only if the gross load that can be weighed is not increased beyond the capacity limit of the device. The following test is to ensure that, when the device SAZSM range is set for more than 4% **Max**, the weighing range decreases by an amount equal or greater than the value, in excess of 4% **Max**, corrected by the SAZSM:

#### Procedure

- Place a load equal to 4% **Max** on the platter, and reset the device to zero using the SAZSM.
- If the device does not reset to zero, there is no need to pursue the test.
- If the device resets to zero, add a load equal to 5% **Max** on the platter. Set the device to zero by activating the SAZSM. Load the device until it blanks. Record the last weight value indicated.

#### Interpretation of results

- Any value in excess of 4% **Max**, corrected by the SAZSM, must result in an equal decrease in the gross load that can be weighed.

### COMBINED ZERO/TARE BUTTONS

See section NAWDS STP-11 for additional requirements regarding this feature.

### OBWS ZERO RETURN

An On-Board Weighing System that is designed and used to weigh dynamically need not return to zero indication between weighings if the system is designed to operate in this manner and calculates accurate Net weights.

#### REVISION

Rev 2. (Jan 2010)

- add requirements for Automatic Zero Setting Mechanism (AZSM/DMZA)
- correct terminology for Automatic Zero Tracking Mechanism (AZTM/AZTM)
- reorder definitions & procedures alphabetically
- added OBWS Zero Return requirements.

<b>Field Inspection Manual</b>	Part: <b>3-STP</b>	Section: <b>8</b>	Page: <b>5 of 5</b>
<b>Non Automatic Weighing Devices</b>	Issued: <b>2010-01-01</b>	Revision Number: <b>2</b>	

#### **STP-8 ZERO SETTING MECHANISMS**

Rev 1. (Mar 2007)

- add 10 second delay on power cycle to IZSM procedure
- clarify Interpretation section for AZSM procedure
- delete "to the Public" form Direct Sales references.
- correct grammatical and general formatting issues.
- correct references to Specifications Relating to Non-automatic Weighing Devices (1998).

<b>Field Inspection Manual</b>	Part: <b>3-STP</b>	Section: <b>9</b>	Page: <b>1 of 2</b>
<b>Non Automatic Weighing Devices</b>	Issued: <b>2009-02-01</b>	Revision Number: <b>2</b>	

## **STP-9 MANUAL WEIGHT ENTRIES**

### **REFERENCE**

Sections 30, 31, 31.1, 32, 33 and 38 of the *Specifications Relating to Non-automatic Weighing Devices (1998)*.

### **PURPOSE**

This section does not apply to keyboard tare entries (see section STP 11 for Tare Requirements). This section does not apply to devices installed and used in Not For Direct Sales applications (see section STP 3.7 for Marking Special Application requirements).

Metrological features of a device used in trade must be of such design, composition and construction so as to ensure accurate measurement and minimize the potential for fraudulent use. Many devices incorporate features that allow the operator to enter a weight value through a numeric keypad or keyboard.

Manual weight entries may be necessary in certain circumstances, such as POS systems, when credit must be given, or when generating labels for standard packages or correcting erroneous tickets. However, this capability may increase the potential for fraudulent device use if it is permitted without suitable precautions.

### **REQUIREMENTS**

Manual weight entries can therefore be allowed under the following conditions:

The device must be incapable of weighing when it is processing or printing a manual weight entry.

Displayed and printed manual weight entries must be adequately defined and must be automatically identified as "Manual Weight", "Manual WT" or "MAN WT" ("poids manuel", "pds manuel" or "PDS MAN").

Manual weight entry must be an optional feature that can be enabled/disabled and sealed against use in applications where its use is inappropriate and could facilitate fraud.

### **CLARIFICATION**

(1) When a manual weight entry is printed and automatically identified as such, displaying the manual weight value is optional. If, however, the manual weight value is displayed, it must be properly identified as such.

(2) Identification of a manual weight entry, with the proper term, must be done automatically without the need for operator intervention.

(3) The use of a symbol to identify multiple manual weight entries is permitted provided that the symbol is defined on the same page as that on which the manual weight entries appear and the definition of the symbol is automatically printed by the recording element as part of the document.

(4) The following symbols are not acceptable: MAN, MW.

<b>Field Inspection Manual</b>	Part: <b>3-STP</b>	Section: <b>9</b>	Page: <b>2 of 2</b>
<b>Non Automatic Weighing Devices</b>	Issued: <b>2009-02-01</b>	Revision Number: <b>2</b>	

### **STP-9 MANUAL WEIGHT ENTRIES**

(5) Manual weight entries made subsequent to the actual weighing transaction are exempt from the requirements for identifying the entry as a manual weight entry. These manual weight entries are typically entered into a computer or other ancillary device and must not originate from or pass to or through the approved indicator.

(6) The entry and the use of both manual gross values and manual tare values are prohibited with on-board weighing systems.

### **REVISION**

Rev. 2 (2009-02-01)

- remove requirement for LRE to be empty before allowing MWE

Rev 1. (2008-01-01)

- clarified manual weight entry requirements.
- exempt Not For Direct Sales devices from complying with manual weight entry requirements.
- allow manual weight entries on vehicle scales even if the scale is not at gross load zero.
- correct references to *Specifications Relating to Non-automatic Weighing Devices (1998)*.
- indicate that manual gross value and manual tare value are prohibited with on-board weighing systems.

Field Inspection Manual	Part: 3-STP	Section: 10	Page: 1 of 2
Non Automatic Weighing Devices	Issued: 2008-01-01	Revision Number: 1	

## STP-10 SLEEP MODE

### REFERENCE

Sections 30 and 31 of the *Specifications Relating to Non-automatic Weighing Devices (1998)*.

### PURPOSE

The sleep mode/zero feature of the device must be designed to ensure accurate measurement and prevent inadvertent errors. This evaluation is performed when the device is initially inspected to ensure that it has been configured properly.

### DEFINITION

"sleep mode" means a function of a device that blanks partially or totally the indications after a defined period of non use, in order to save the screen or to display information other than weights.

### REQUIREMENTS

A device may go in a sleep mode or may display non metrological information such as advertisements, greetings, time and date, etc. provided that the following conditions are met:

The scale totally or partially blanks its indications or displays non metrological information only when the device is at "Gross" load zero (no load) and has reached a zero-balance condition.

If the device blanks its indications partially only or displays non metrological information, the displayed information cannot be construed as weight indications.

Printing function must be inhibited when the device is in sleep mode.

The scale must be provided with an automatic means to inhibit the weighing operation or return the device to a continuous digital indication when the scale is in an out-of-balance condition. Perform the test below.

### ACCEPTABLE ALTERNATIVES

(1) The device may go into sleep mode with a load on the platter provided that it is designed to prevent any further weighing operations before the operator removes the load from the platter, cancels the tare and resets the device to zero. In this case the device must bear, adjacent to the weight display, the following marking: "The device is at zero when in sleep mode" or equivalent statement.

## MEANS OF AUTOMATICALLY RESTORING WEIGHT INDICATION

### PURPOSE

To ensure that the device is designed to detect an out-of-balance condition and return to weight indication. Also to ensure that the printing function is inhibited when in sleep mode. **The following test is performed when the device is initially inspected only.**

### PROCEDURE

Ensure that the "sleep mode" function is activated;

Zero the device and wait until it goes to the "sleep mode" or displays non metrological messages;

In one firm motion (so as to prevent the AZTM from capturing part of the test load) apply a load equal to  $1e$ . The non-zero/non-metrological registration must have been replaced by a mass registration equal to  $1e$ ;

Wait 5 minutes (or the normal delay for the device to return to the sleep mode) to see if the device will go

<b>Field Inspection Manual</b>	Part: <b>3-STP</b>	Section: <b>10</b>	Page: <b>2 of 2</b>
<b>Non Automatic Weighing Devices</b>	Issued: <b>2008-01-01</b>	Revision Number: <b>1</b>	

### **STP-10 SLEEP MODE**

into a "sleep" mode with a load on the platter;  
Zero the device with the load on the platter and wait until a non-zero/non metrological indication appears;  
Attempt to print;  
In one firm motion, remove the test load equal to 1e. The non-zero/non metrological message must have been replaced by a mass indication equal to (minus) 1e, or by an under-weight indication.

### **INTERPRETATION OF RESULTS**

The device complies with the requirements if:

it does not go into a "sleep" mode when there is a load on the platter;  
it returns to a weight indication when an off-zero condition exists;  
the printing function is inhibited.

The device meets the requirements also if, in the case it goes to "sleep" mode with a load on the platter, it prevents any further weighing before the load is removed, tare is cancelled and the device is re-zeroed.

### **REVISION**

Rev 1. (June 2007)

- Clarify requirement for marking the device when in sleep mode. This change corrects a contradiction between the *Approval Evaluation Manual* and this manual.
- correct references to *Specifications Relating to Non-automatic Weighing Devices (1998)*.

Field Inspection Manual	Part: 3-STP	Section: 11	Page: 1 of 7
Non Automatic Weighing Devices	Issued: 2008-01-18	Revision Number: 2a	

## STP-11 TARE

### REFERENCE

Sections 31 of the *Specifications Relating to Non-automatic Weighing Devices (1998)*.

### PURPOSE

Tare features must be designed and used to ensure accurate measurement and prevent the perpetration of fraud. There are numerous requirements that establish the proper operation of tare features depending upon the type of devices, the type of tare capability and the intended use of the device.

The extent of the requirements depends upon the application. For instance, design and operation requirements for devices used in direct sales are more stringent than those applicable to devices used in other applications. In general, and unless otherwise specified for particular types of tare, devices must provide a clear indication for both the operator and the consumer that a tare value has been entered; platter and keyboard tare values must be visible at some point during the weighing process and the alteration of platter or keyboard tare values, during the weighing process, must be impossible without being noticed. On the other hand, devices that are used in industrial applications or in other applications where the consumer is not normally present need only provide the operator with a clear indication that a tare value has been entered and have a means to display the tare value on demand.

The Approval Service Laboratory (ASL) performs an extensive evaluation of device tare functions, many of which are configurable or programmable. An exception to the rule is POS systems for which the ASL does not conduct the approval testing of the electronic cash registers which perform the tare operations. Field inspectors must therefore ensure that tare functions are configured within allowable parameters, particularly when devices are initially inspected.

### EXTRACTS FROM THE APPROVAL EVALUATION MANUAL - NON AUTOMATIC WEIGHING DEVICES

Hereafter are the detailed marking requirements as extracted from the Approval Evaluation Manual - Non Automatic Weighing Devices. This extract is provided to ensure uniform and consistent application of the tare requirements in the field. Note that the numbering of the following sections correspond to the numbering used in the Approval Evaluation Manual - Non Automatic Weighing Devices.

### DEFINITIONS

**Tare (n):** the weight of a container or wrapper. *Tare Weight* is subtracted from *Gross Weight* to obtain *Net Weight*.

**Tare: (v):** the practice of removing the weight of the container or wrapper. May be accomplished manually or automatically using the devices built in tare features.

**Additive Tare:** means a tare entry that does not affect the device weighing capacity. A keyboard or platter tare entry of 10 kg on a 15 kg capacity scale that has an additive tare feature will still leave the possibility of weighing a net load of 15 kg.

**Automatic/Auto Tare:** means an automatic platter tare. With the scale indication at zero, the scale automatically tares, within a pre-determined range, the value of the first load (container) put on the platter. The "Net" weight of the commodity is then determined.

Field Inspection Manual	Part: 3-STP	Section: 11	Page: 2 of 7
Non Automatic Weighing Devices	Issued: 2008-01-18	Revision Number: 2a	

## STP-11 TARE

**Keyboard Tare:** means a fixed or percentage tare value entered through the keyboard (e.g. 20 g, 1.3%, etc.) or through one of the selectable tare keys to which tare values are assigned.

**Percentage Tare:** means a tare value, expressed as a percentage (e.g. 5.6%), that represents the percentage of tare material compared to the gross weight of the commodity. A percentage tare is one form of proportional tare.

**Platter Tare:** means a tare entry achieved by placing an object (e.g. a container, bag, etc.) on the platter and pressing the tare key. The device then indicates zero as the net weight with the object on the platter.

**Preprogrammed Tare:** means a tare value that has been entered, retained in the device memory and assigned to a PLU code or product name. It can be a fixed tare value and/or a proportional tare value.

**Proportional Tare:** means a tare value, automatically calculated by the scale, proportional to the gross weight indicated by the scale. A proportional tare can be a percentage tare or a fixed tare value proportional to a range of gross weights (i.e., a 10 g tare for gross weights between 0 and 2 kg, a 20 g tare for gross weights between 2 kg and 4 kg, etc.). A proportional tare is, therefore, not limited to being a percentage tare.

### 11.1 - APPLICABLE TO ANY TYPE OF SCALE OR WEIGHING SYSTEM AND TO ANY TYPE OF TARE

11.1.1 - The tare mechanism must only operate in the backward direction (under-registration).

11.1.2 - The device must ignore or reject the entry of a zero tare value. The entry of a zero tare (or a 0% proportional tare) must not activate the "Tare Entered" or "Net" annunciator nor cause the display to automatically switch to the "Net" display mode. (Scales with a continuous tare display or tare display mode will indicate zero when the tare entry is zero. However, the entry of a zero tare must not cause the display to automatically switch to the net mode).

11.1.3 - The tare value must be equal to the value of the displayed scale division for all methods of tare entry ( $d_{tare} = d$ ). An attempt to enter a tare value that is not equal to  $d$  must be rejected or rounded off to the nearest scale interval (see section STP 28 for specific requirements pertaining to multi-interval and multiple range devices).

11.1.4 - The tare weight signal must be "free floating". If the tare value is changed during the weighing operation, the net weight must be re-adjusted accordingly (**Net + Tare = Gross**).

11.1.5 - The sum of the **Tare** value entered or preprogrammed and the **Net** weight that can be weighed must not exceed the **Gross** weight capability of the device (**Max + 9e** for computing scales - and preferred for all scales; **Max + 5%** for other scales). See the blanking display test in section STP 18.

This does not preclude a device from having a full capacity tare plus a full capacity weighing range (additive tare). In such a case, tests for accuracy, repeatability, eccentricity, etc. must be performed based on the maximum weighing capacity with the maximum tare value entered.

11.1.6 - It shall not be possible to enter a value of tare that exceeds the tare capability range (e.g. a tare entry of 6 kg on a scale with a tare range of 5 kg must be rejected and not taken as 5 kg).

Field Inspection Manual	Part: 3-STP	Section: 11	Page: 3 of 7
Non Automatic Weighing Devices	Issued: 2008-01-18	Revision Number: 2a	

## STP-11 TARE

11.1.7 - Whenever **Net**, **Gross** and **Tare** weights are indicated or printed, they must be in exact mathematical agreement (**Net + Tare = Gross**) and the total price must be calculated on the basis of the net weight.

11.1.8 - The use of any mechanism to select the unit of measure (lb/kg switch) must be inhibited when a tare is entered (through the keyboard, platter or preprogrammed) unless all weight values, including the tare value, are automatically converted and accurately rounded off to the nearest scale interval.

11.1.9 - If a device is designed to automatically clear the tare after each weighing, it must also be designed to prevent the automatic clearing of a tare before a stable weight indication has been provided and the transaction completed.

### CLARIFICATION

On a price computing scale, the transaction is only completed with the entry of a unit price and the computation of the total price. The removal of the commodity from the platter before the total price is computed must not automatically cancel the tare.

## 11.2 - PLATTER AND KEYBOARD TARE

11.2.1 - Pressing the tare button once, or several times, with a load on the platter (platter tare) must set the device to zero and only to zero.

11.2.2 - Except for Point of Sale (POS) systems, the device must provide a visual confirmation or indication that a platter or keyboard tare has been entered (see the particular requirements for preprogrammed tares and POS systems).

### ACCEPTABLE MEANS OF PROVIDING VISUAL CONFIRMATION:

- (1) The device has a separate and continuous tare display.
- (2) The device displays simultaneously or in sequence (within a time interval of a few seconds), for both the operator and the consumer, the gross, tare and net weights with their proper descriptors.
- (3) The device displays the net weight only, with net weight annunciator near the weight display. Gross weight is displayed and the net weight or annunciator goes off when the tare weight is zero.
- (4) The device has selectable Gross and Net weight display modes with proper descriptors and annunciators.

### (ACCEPTABLE MEANS OF PROVIDING VISUAL CONFIRMATION)

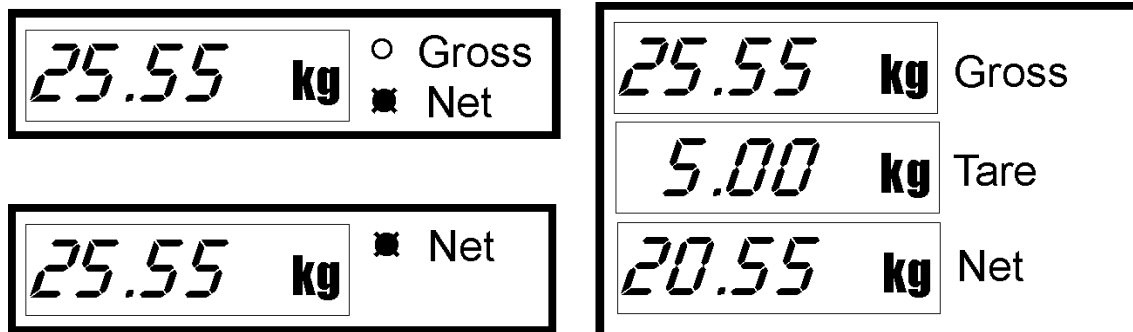

Field Inspection Manual	Part: <b>3-STP</b>	Section: <b>11</b>	Page: <b>4 of 7</b>
Non Automatic Weighing Devices	Issued: <b>2008-01-18</b>	Revision Number: <b>2a</b>	

### STP-11 TARE

(5) It is recommended that video display terminals that are the primary indicators of devices simultaneously display the Gross and Tare weights when the Net weight value has been determined.

**NOTE:** Appropriate annunciators or descriptors must go "on" when tares are entered; not "off".

11.2.3 - The entry of a platter or keyboard tare must automatically override any previous tare entry or be rejected (i.e. they cannot be additive). A percentage tare value may however be entered in addition to a fixed keyboard or platter tare value.

11.2.4 - Unless a separate tare display is provided, the device must display a negative weight value when the weight of the load on the platter is smaller than the tare weight.

### 11.3 - PREPROGRAMMED TARE (FIXED OR PERCENTAGE)

11.3.1 - Preprogrammed tare values may only be assigned (programmed) when the device is at gross load zero and in a "configuration" mode.

11.3.2 - Fixed and/or percentage tares may be preprogrammed into PLU codes. PLU codes may be entered or changed at any time, whether or not a load is on the platter.

11.3.3 - Except for POS systems, scales must display the Net weight ("net"on) when a preprogrammed tare is entered through a PLU code.

### 11.4 - PERCENTAGE TARE

11.4.1 - Fixed and percentage tares may be added to obtain a total tare value for a transaction. For instance, a PLU code may be preprogrammed with cumulative fixed and percentage tares; or a fixed platter or keyboard tare may be entered first, and then, through a PLU code, a percentage tare applied.

11.4.2 - If a device can sum fixed and percentage tare values, the two values must be added first and then the total tare value rounded off to the nearest scale interval. There is therefore no benefit in expressing percentage tare values with more than one decimal place (e.g. 1.5%, 3.3%, etc.).

### EXAMPLES:

**Scale:** 15 kg x 5 g

Total gross weight TGW	Fixed tare weight FTW	Gross weight GW = TGW - FTW	Percentage tare value %T	Percentage tare weight calculated GW x %T	Total gross weight TGW	Total tare (fixed + percentage)		Net weight NW
						Calculated	Rounded	
355 g	10 g	345 g	9.2%	31.74 g	355 g	41.74 g	40 g	315 g

**Scale:** Multi-interval

0-2 kg x 1 g  
2-5 kg x 5 g

Field Inspection Manual	Part: <b>3-STP</b>	Section: <b>11</b>	Page: <b>5 of 7</b>
Non Automatic Weighing Devices	Issued: <b>2008-01-18</b>	Revision Number: <b>2a</b>	

### STP-11 TARE

Total gross weight TGW	Fixed tare weight FTW	Gross weight GW = TGW- FTW	Percentage tare value %T	Percentage tare weight calculated GW x %T	Total gross weight TGW	Total tare (fixed + percentage)		Net weight NW
						Calculated	Rounded	
2890 g	9 g	2881 g	11.2%	322.672 g	2890 g	331.672 g	330 g <sup>1</sup>	2560 g
							332 g <sup>2</sup>	2558 g <sup>3</sup>

<sup>1</sup> - Tare rounded to the nearest 5 g scale interval (interval for weighing range of the gross weight).

<sup>2</sup> - Tare rounded to the nearest 2 g scale interval (interval for weighing range of the tare weight).

<sup>3</sup> - See sections STP 28.1.7 and STP 28.1.10 for specific requirements applicable to multi-interval and multiple range devices.

11.4.3 - The visual confirmation that a tare has been applied (i.e. Net annunciator) must only be enabled if the percentage tare multiplied by the gross weight represents one or more scale intervals after the appropriate rounding. The turning on of the Net annunciator must only occur if the net weight does not equal the gross weight (i.e. a tare has actually been applied to the gross weight).

#### NOTE:

These acronyms are used in the following equations:

%T (Percentage tare)

TW (Tare Weight)

GW (Gross Weight)

NW (Net Weight)

TGW (Total Gross Weight)

FTW (Fixed Tare Weight)

The %T of a commodity is determined as follows:

$$\%T = TW \div GW \times 100$$

NW is determined as follows:

$$NW = TGW - FTW - [(\%T)(TGW-FTW)]$$

### 11.5 - DEVICES USED FOR DIRECT SALES

11.5.1 - Except for preprogrammed tare, proportional tare and POS systems, when keyboard or platter tare values are entered the scale must comply with one of the following requirements:

11.5.1.1 - the tare value is permanently indicated on a separate dedicated display; or

11.5.1.2 - the tare value is indicated as a negative value when there is no load on the load receiving element;

Field Inspection Manual	Part: <b>3-STP</b>	Section: <b>11</b>	Page: <b>6 of 7</b>
Non Automatic Weighing Devices	Issued: <b>2008-01-18</b>	Revision Number: <b>2a</b>	

## STP-11 TARE

11.5.2 - A platter or keyboard tare value may not be entered, modified or cancelled unless the device is at gross load zero or the device indicates a negative weight value. This does not apply when the tare is continuously indicated on a separate dedicated display (or, as a minimum, the new tare value is clearly displayed to the customer at some point during the transaction) nor to a preprogrammed tare associated with a PLU.

### EXAMPLE:

A platter or keyboard tare value is entered on a computing scale and a negative value is indicated. If the wrong tare value was entered, it may be cancelled and replaced by a new tare value when the platter is empty. This new tare value will be indicated as a negative weight value. However, the correction must not be possible with a commodity resting on the platter (positive weight indication). In such instances, the operator must remove the commodity from the platter and then cancel or change the tare value.

### CLARIFICATION:

The zero indication/no load condition does not apply to a preprogrammed tare value. The idea being that the operator should not be capable of altering a tare value without providing the consumer with an indication that a new tare value has been entered. In the case of a preprogrammed tare associated with a PLU code, the tare value is rarely displayed. However, it is unlikely that the operator will select the wrong PLU code or product name, or change the PLU code during the weighing operation, to reduce the tare value. Such actions would affect the unit price and would be detectable by the consumer.

11.5.3 - Platter or keyboard tare values may be retained between transactions.

11.5.4 - Auto-tares are prohibited in direct sale to the public applications.

## 11.6 - DEVICES INTENDED FOR INDUSTRIAL APPLICATIONS OR OTHER APPLICATIONS WHERE CONSUMERS ARE NOT NORMALLY PRESENT

11.6.1 - A tare may be cancelled or modified while a load is on the load receiving element provided that the device has means to indicate, on demand, the value of the tare. These means include a negative weight value displayed when the platter is empty or a means to recall the tare value. A clear indication must be provided to the operator that a tare has been entered or cancelled (a tare annunciator is sufficient).

11.6.2 - Tare values may be retained between transactions.

11.6.3 - Combined semi-automatic zero/tare buttons are permitted under the following conditions:

11.6.3.1 - The zero/tare mechanism operates only when the scale provides a stable indication; the mechanism sets the indication to zero, only, within  $\pm 0.25e$  (or  $0.5d$  for Class I and II devices equipped with auxiliary reading means); the zero range does not exceed 4% of scale capacity unless the gross load that can be weighed is not increased beyond scale capacity.

11.6.3.2 - The scale is intended to be used exclusively for industrial applications or applications where consumers are not normally present.

11.6.3.3 - The AZTM or Center-of-Zero annunciator must be effective when the device displays zero after a zero setting operation (within the zero range). The AZTM may also work when zero is indicated after a tare operation.

Field Inspection Manual	Part: <b>3-STP</b>	Section: <b>11</b>	Page: <b>7 of 7</b>
Non Automatic Weighing Devices	Issued: <b>2008-01-18</b>	Revision Number: <b>2a</b>	

## STP-11 TARE

11.6.3.4 - The AZTM does not re-zero weight values in excess of 0.6e; the total AZTM range does not exceed 4% of scale capacity unless the gross load that can be weighed is not increased beyond scale capacity.

11.6.3.5 - The scale must be permanently marked, near the weight display(s), with the legend "Not for Use in Direct Sales" or similar language and the ranges of both zero and tare operation (e.g. Zero Range up to 7d - Tare Range above 7d).

11.6.3.6 - The range of zero and tare operation must not be user selectable (i.e. fixed or, as a minimum, a sealable parameter).

11.6.3.7 - Visibility of operation - the scale is required to display an indication (Net annunciator) that a tare has been entered when a weight value within the tare range is subtracted by activating the zero/tare button.

## 11.7 - POINT OF SALE SYSTEMS

11.7.1 - A POS system may display the Gross weight on the scale display; however, it must print the Net weight on the cash register tape. The scale of a POS system is not required to display the net weight nor provide an indication that a tare value has been entered.

## 11.8 - MULTI-INTERVAL AND MULTIPLE RANGE SCALES

See section STP 28 (Multi Interval / Multi Range Device) of this manual.

## 11.9 - CUSTOMER DISPLAY

See section STP 7 (Installation and Location of the Device) of this manual.

## REVISION

### Rev 2.

- removed all remaining references to Laboratory Evaluation Manual.
- 11.1.5 added prefer +9e for all scales, although +5% is still allowable. (9e will always be less than 5% Max).
- change reference from "Direct Sales to the Public" to "Direct Sales".
- change all remaining fractions to decimals to maintain consistency throughout FIM.
- rename section 11.9 to Customer Display
- correct reference to *Specifications Relating to Non-automatic Weighing Devices (1998)*.
- remove definition of POS from this STP. See IPO 2.20 (POS)

### Rev 1.

- Section 11.8 reference STP 28 of this manual

<b>Field Inspection Manual</b>	Part: <b>3-STP</b>	Section: <b>12</b>	Page: <b>1 of 1</b>
<b>Non Automatic Weighing Devices</b>	Issued: <b>2004-03-01</b>	Revision Number: <b>Original</b>	

## **STP-12 FREE FLOATING WEIGHT SIGNAL**

### **REFERENCE**

Sections 19, 32, 33 and 55 of the Non Automatic Weighing Devices Specifications.

### **PURPOSE**

To ensure that the displayed net weight and total price are free floating. That is, when the scale display's a unit price, a weight and a total price, if the weight or the unit price is changed the total price must change accordingly. All applicable tests to be performed.

### **PROCEDURE**

#### **Price computing scale**

- Place a load on the platter.
- Enter a unit price; a total price is now displayed. Ensure that the indicated monetary value is in mathematical agreement with the weight and the unit price, to the nearest cent.
- Increase the load on the platter; the total price must increase accordingly.

#### **Scale equipped with a tare display**

- Enter a keyboard or a platter tare value.
- Place a load on the platter that is greater than the value of the tare; the scale display's a gross weight, a tare weight and a net weight.
- Ensure that the gross, tare and net weight values are in exact mathematical agreement.
- Change the tare value; the net weight should change accordingly.

#### **Computing Scales and POS systems - Against a Price Lookup Code (PLU)**

- Determine the keying sequence necessary to cause the device to compute a final price using a preprogrammed PLU code.
- Place a load on the platter.
- Key in the complete sequence except the last keystroke required for price computation.
- Change the load on the platter.
- Operate the final keystroke to initiate price computation.

#### **POS systems - Against a Manually Scaled Item**

- Determine the keying sequence necessary to cause the device to read the scale; allow the operator to enter a price per unit (\$/kg) and , if applicable, a department code; then compute a final price.
- Place a load on the platter.
- Key in the complete sequence except the last keystroke required for price computation.
- Change the load on the platter.
- Operate the final keystroke to initiate price computation.

### **INTERPRETATION OF RESULTS**

In all circumstances, mathematical agreement must be maintained.

POS systems must either compute total prices using the load on the scale at the time of the final keystroke, produce an error signal or lock out to prevent any price computation.

### **REVISION**

Original document

Field Inspection Manual	Part: 3-STP	Section: 13	Page: 1 of 4
Non Automatic Weighing Devices	Issued: 2004-03-01	Revision Number: Original	

## STP-13 INCREASING / DECREASING TEST AND RETURN-TO-ZERO TEST

### REFERENCE

Sections 8, 9, 11 and 16 of the Non Automatic Weighing Devices Specifications.

### PURPOSE

The purpose of this test is to determine the basic performance characteristics of the scale - linearity, accuracy and hysteresis.

### PRETEST DETERMINATION

#### **A scale that incorporates an IZSM the range of which exceeds 20% of Max:**

If a scale has an initial zero setting mechanism (IZSM) the range of which can exceed 20% of Max, this should be mentioned in the Notice of Approval. If such a scale is used with more than one load receiving element or platter, the scale uses an "extended" range of the load cell(s). At the initial inspection, this "extended" weighing range is tested. The device is therefore set to zero using the IZSM and an increasing load test is performed to capacity. The scale is then re-zeroed by activating the IZSM with the load on the platter. The increasing load test is then continued until the device blanks (Max + IZSM range). This "extended" increasing load test is not necessary if the IZSM range is limited to 20% of Max.

#### **Scale equipped with an additive tare feature**

An additive tare feature allows a tare of a load equal to Max without reducing the weighing range of the device. If the scale has a full or partial additive tare, the full range of the additive tare and the weighing range must be tested. Set the device to zero and perform an increasing load test up to Max (or the maximum tare effect). Tare the load on the platter and complete the increasing load test up to Max + the additive tare effect. Remove the loads in reverse sequence (decreasing load test).

### Selection of Test Loads

Use at least five known test loads for the increasing and decreasing tests. When practical, choose the loads so that they are close to the turning point (the point where the limit of error increases) of each limit of error step. For instance, on a Class III scale, loads must be close to but not greater than 500 e, 2000 e, 4000 e and Max. In the case of multi-interval devices, more than five known test loads may be necessary as there could be more than five turning points.

### "Small Weight" Method

This is a procedure to determine the true error (or internal error) of a digital indicating scale by adding to or removing small weights corresponding to 1/10 e from the load receiving element. This procedure is used to bring the scale to the same exact weight indication when replacing the known weights by material when performing a strain or substitution test.

## TEST PROCEDURES

### Using Known Test Weights up to Max

- Zero the scale.
- Successively apply a minimum of five known test loads from zero to Max taking into consideration the instructions provided under "Selection of test loads" above.
- Remove the loads in reverse sequence.
- Record the weight indications for each load and at zero upon the removal of the load.

### Strain Load Tests

When the amount of test weights available is less than Max, unknown loads are used to test the device up to its maximum capacity.

Field Inspection Manual	Part: <b>3-STP</b>	Section: <b>13</b>	Page: <b>2 of 4</b>
Non Automatic Weighing Devices	Issued: <b>2004-03-01</b>	Revision Number: <b>Original</b>	

### STP-13 INCREASING / DECREASING TEST AND RETURN-TO-ZERO TEST

- Zero the scale and test the low range of the scale by performing an increasing and decreasing load test using the available known test weights.
- Place a strain load on the load receiving element and note the exact weight indication using the "small weights" method, or tare the load. Do not use the zero setting mechanism to set the strain load to zero.
- Successively apply the known test weights taking into consideration the instructions provided under "Selection of test loads" above.
- Remove the known test loads in reverse sequence.
- After the completion of the strain load test, remove the unknown strain load and the known test weights, cancel the tare (if applicable) and ensure that the device has returned to zero.

#### Number of Strain Tests

The minimum number of strain load tests for initial and subsequent field inspections is:

**two** for platform scales: one near the mid range of the scale capacity and one close to the range of use of the device;

**three** for hopper and tank scales: one at approximately 30% of Max, one at approximately 60% of Max and one between 90% and 100% of Max;

**two** for vehicle scales or combination vehicle/railway scales: one within the normal tare weighing range and one within the normal gross weighing range of the device; and

**two** for railway scales: one within the normal tare weighing range and one within the normal gross weighing range of the device.

#### Substitution Tests

Substitution tests may be conducted on platform scales, hopper scales and tank scales if performed under stable environmental conditions (no wind, no rain). The weight indication and the weight of the substitution material must both be stable.

- Set the device to zero.
- Apply the known test weights to the load receptor taking into consideration the instructions provided under "Selection of test loads" above. Note the exact weight indication using the "small weights" method and record the error. Remove the test weights (decreasing load test).
- Add sufficient material to the load receiving element to exactly duplicate the indication obtained with the test weights. This is now considered to be a known test load.
- Apply the test weights to the load receptor.
- Repeat the procedure up to Max.

#### INTERPRETATION OF RESULTS

For each increasing and decreasing load test, the error of indication must be within the limits of error.

When unloaded the device must return to zero within 0.5 e, within:

**5 seconds**, for scales of any capacity that normally weigh single discrete loads, applied and removed in a single unit (computing scales, platform scales, overhead track scales, etc.).

**15 seconds**, for scales up to 10 000 kg in capacity that normally weigh product that is not applied in one discrete load (hopper and tank scales).

<b>Field Inspection Manual</b>	Part: <b>3-STP</b>	Section: <b>13</b>	Page: <b>3 of 4</b>
<b>Non Automatic Weighing Devices</b>	Issued: <b>2004-03-01</b>	Revision Number: <b>Original</b>	

### **STP-13 INCREASING / DECREASING TEST AND RETURN-TO-ZERO TEST**

**30 seconds**, for scales over 10 000 kg in capacity that normally weigh product that is not applied in one discrete load (vehicle scales, railway scales, hopper and tank scales).

When a strain load test is performed, upon the removal of the known test weights, the scale must return to the initial indication within 0.5 e.

#### **NOTE 1**

When performing strain load tests, the limit of error applies to the known test load that is added to the strain load. Limits of error are applied as if the scale started at zero.

#### **NOTE 2**

When performing substitution tests, the limit of error applies to the total load on the load receiving element (the sum of the known test load and the substitution material).

#### **NOTE 3**

For field tests, except for load discrimination tests, strain tests and substitution tests, there is no need to establish the true internal error using the "small weights" method. Limits of error apply to the difference between the weight value indicated or recorded and the value of the known test load.

#### **NOTE 4**

Limits of error apply to gross weights as well as net weights. For instance, a platter tare value of 600 e is entered. The scale indicates zero (net) with the 600 e load on the platter. From zero to 500 e (net), the in-service limit of error is then 1 e and not 2 e.

#### **NOTE 5**

Despite any variation between results permitted by the Specifications, all results must be within the limit of error envelope.

### **MULTIPLE RANGE WEIGHING DEVICES**

#### **Procedure**

Each weighing range is tested individually.

- Zero the scale.
- Successively apply a minimum of five known test loads from zero to Max.
- Remove the loads in reverse sequence.
- Record the weight indications for each load and at zero upon the removal of the loads.
- Repeat the test for each range.
- Load the scale to the maximum capacity of the highest range (or manually select the highest range and then load the device to capacity).
- Remove the load - the indications should return to zero.
- Immediately, switch the device to the lowest range (if the switch over is automatic the device should have returned to the lowest range automatically). Record the indication near zero at the time the device switches to the lowest range.

#### **INTERPRETATION OF RESULTS**

Multiple range devices must:

- for each load, provide a weight indication within the limits of error envelope as prescribed by the Non Automatic Weighing Devices Specifications; and

<b>Field Inspection Manual</b>	Part: <b>3-STP</b>	Section: <b>13</b>	Page: <b>4 of 4</b>
<b>Non Automatic Weighing Devices</b>	Issued: <b>2004-03-01</b>	Revision Number: <b>Original</b>	

**STP-13 INCREASING / DECREASING TEST AND RETURN-TO-ZERO TEST**

-return to zero from  $Max_i$  within  $0.5 e_i$ . After returning to zero from any load greater than  $Max_i$ , and immediately after switching to the lowest weighing range, the indication must be within  $0.5 e_i$ .

**REVISION**

Original document

Field Inspection Manual	Part: <b>3-STP</b>	Section: <b>14</b>	Page: <b>1 of 2</b>
Non Automatic Weighing Devices	Issued: <b>2004-03-01</b>	Revision Number: <b>Original</b>	

## STP-14 LOAD DISCRIMINATION TEST

### REFERENCE

Sections 14 and 15 of the Non Automatic Weighing Devices Specifications.

### PURPOSE

The load discrimination test is used to determine whether the device is capable of sensing a small change of load and of changing its registration accordingly. Frictional forces, binding or system inertia can prevent a mechanical device from sensing the prescribed "Load Discrimination Test Load". Frictional forces, binding, the use of oversized (capacity) load cells, the use of an electronic indicator with an inadequate display sensitivity ( $\mu$  Volts/Display Digit) or inadequate digital filter algorithms could cause an electronic weighing device to fail to detect the addition of the prescribed "Load Discrimination Test Load". This test is performed at no load and near Max.

**NOTE:** the load discrimination test is based on " d " and not " e "

### PROCEDURES

#### For Automatic Digital Indicating Devices

**NOTE:** the following **official procedure** is performed at the time of approval and initial inspection at the factory.

- If the device is equipped with an AZTM, put a small load on the platter to bring the scale out of its AZTM range. The indication is near zero. Otherwise the test can be performed at zero.
- Successively add small weights equal to 0.1 d until the low end of the Zone of Uncertainty (ZU) is reached; remove one small weight to obtain a solid indication; the indication is at the high point of the scale interval.
- Smoothly add a load equal to 1.4 d. Record the indication.
- Repeat the test near the maximum capacity.

This test can be performed backward. The indication must be brought at the low end of the scale interval, instead. Then a load equal to 1.4 d is removed.

**NOTE:** the following **simplified procedure** is applied when a device is initially inspected on site and at the time of subsequent inspections. The official procedure remains the one above. In case of a dispute over the results or when an inspector judges it appropriate, the official procedure described above is used.

- If the device is equipped with an AZTM, put a small load on the platter to bring the scale out of its AZTM range. The indication is near zero. Otherwise the test can be performed at zero.
- Note the indication.
- Smoothly add a load equal to 1 d. Record the indication.
- Repeat the test near the maximum capacity.

#### For Weight Classifiers

The same test is performed on weight classifiers. However, inspectors must take into consideration that the ZU (turning point) follows immediately the interval.

Field Inspection Manual	Part: <b>3-STP</b>	Section: <b>14</b>	Page: <b>2 of 2</b>
<b>Non Automatic Weighing Devices</b>	Issued: <b>2004-03-01</b>	Revision Number: <b>Original</b>	

## STP-14 LOAD DISCRIMINATION TEST

### INTERPRETATION OF THE RESULTS

In the case of the official procedure, the addition or the removal of the load must cause a change of indication of 2 d. In the case of the simplified (on site) procedure, the addition or the removal of the load must cause a change of indication of 1 d.

### For Automatic Analogue Indicating Devices (dial, fan type)

- At no load condition, press on the platter to generate a motion of the indicating element (pointer). Allow the indicator to stabilize.
- Smoothly add (or remove) a load equal to 1.4 d; allow the indicator to stabilize. Record the indication.
- Repeat the test near the maximum capacity.

### INTERPRETATION OF THE RESULTS

The addition or removal of the load must cause a change of indication of at least 1 d.

### For Non Automatic Indicating Devices - Beam scales with no additional means of indication

- Set the device to zero (Horizontal position and mid distance between the trig loops or limiting stops).
- Add or remove a load equal to 1 d (in-Service limit of error), when the test is performed near zero.
- Repeat the test near Max. Add or remove a small load corresponding to the in-Service limit of error applicable to the load on the platter, without exceeding 2 d.

### INTERPRETATION OF THE RESULTS

The addition or removal of the load must cause the weighbeam to change from the center position to the outer limit of the trig loop or limiting stops.

### For Non Automatic Indicating Devices - Beam with additional indicating element (Over/Under Indicator having graduations without values)

- Set the device to zero.
- Add or remove a load equal to 1 d (in-service LOE), when the test is performed near zero.
- Repeat the test near Max. Add or remove a small load corresponding to the In-Service LOE applicable to the load on the platter, without exceeding 2 d.

### INTERPRETATION OF THE RESULTS

The addition or removal of the load must cause the position of the indicator to change by the applicable value indicated below:

- **1 mm** for Class I and II devices
- **2 mm** for Class III and IIII devices with Max  $\leq$  30 kg
- **5 mm** for Class III, III HD and IIII devices with Max  $>$  30 kg

### REVISION

Original document

Field Inspection Manual	Part: 3-STP	Section: 15	Page: 1 of 12
Non Automatic Weighing Devices	Issued: 2008-10-01	Revision Number: 4	

**STP-15      ECCENTRICITY TEST**

**REFERENCE**

Sections 11 and 13 of the Specifications Relating to Non-Automatic Weighing Devices (1998).

**PURPOSE**

The purpose of this test is to reveal the ability of load cell(s), load cell mounting and check systems of a weighing element to resist or compensate for the torsion effects of non axial loads. This test also ensures that the load cells of electronic scales, the levers of mechanical scales, or both in the case of electro-mechanical scales, are adequately "balanced" in order to obtain accurate weighing. The device must be capable of weighing accurately in spite of changes of position of the test load over the load receiving element.

**Bench, Counter, Platform & Equal Arm Scales**

**PROCEDURE**

- Zero the device.
- Apply a test load of  $\frac{1}{3}$  **Max** (between 30% and 35% is acceptable) on the center of the platter (position number 1 on the appropriate graphic below). Record the indication. This position establishes the Maximum Permissible Error (MPE) applicable to the load.
- Apply the same test load on the device in such a manner that the center of gravity of the test load lies approximately at the center of one of the numbered target boxes in the following illustrations. Record the indication.
- Proceed in the same manner with each of the other numbered target boxes. The test load should not overhang the edge of the Load Receiving Element (LRE). Record the indication.
- Most LRE's will be rectangular, however regardless of the shape of the LRE, it should be divided into quarters as illustrated and the appropriate test load applied in the approximate center of each quarter.

**Not More Than Four Support Points (Number of Support Points  $\leq$  4)**

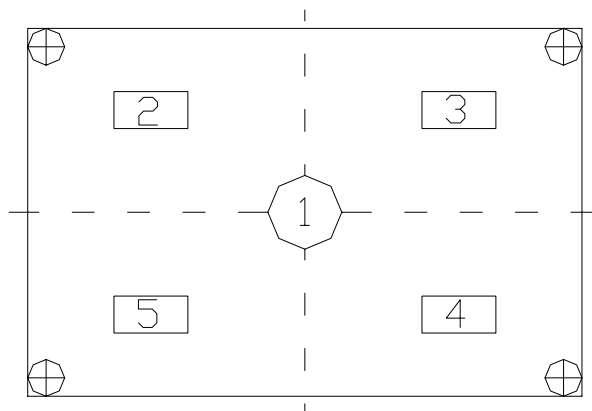

Field Inspection Manual	Part: 3-STP	Section: 15	Page: 2 of 12
Non Automatic Weighing Devices	Issued: 2008-10-01	Revision Number: 4	

## STP-15 ECCENTRICITY TEST

**OPTION:** 25% *Max* placed on the LRE over the load cell may also be use to perform corner tests on platform, floor or bench scales having four (4) support points.

### Equal Arm Scales

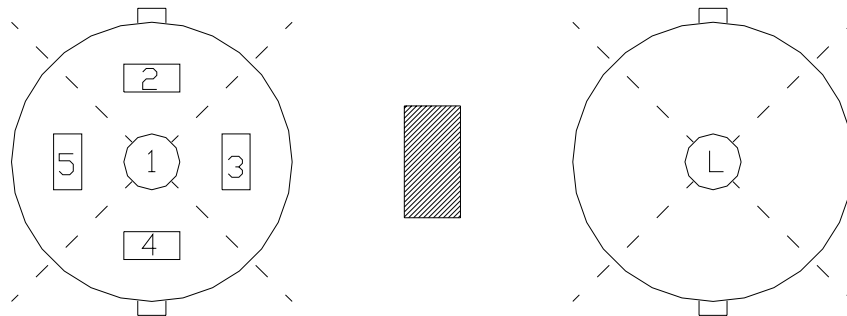

**NOTE:** When testing equal arm scales of the 'pan over beam' type, the test loads should be applied first to one LRE then the other LRE of the device. A suitable counterweight (L) should be placed in the center of the opposite LRE.

### More Than Four Support Points (Number of Support Points > 4)

#### PROCEDURE

Larger platform scales and other scales with more than four points of support.

- Zero the device.
- Apply a test load equal to  $1 / (n - 1)$  *Max* to the center of the platter (Position number 1). Record the indication. This position establishes the Maximum Permissible Error (MPE) applicable to the load. (*n* = number of support points).
- Divide the surface area of the Load Receiving Element (LRE) into  $1/n$  segments, each over one of the load support points. Apply the same test load on the device in such a manner that the center of gravity of the test load lies at the center of each segment. Record the indication. (*n* = number of support points).
- Proceed in the same manner with each of the other segments. The test load should not overhang the edge of the LRE. Record the indication.

Field Inspection Manual	Part: 3-STP	Section: 15	Page: 3 of 12
Non Automatic Weighing Devices	Issued: 2008-10-01	Revision Number: 4	

**STP-15      ECCENTRICITY TEST**

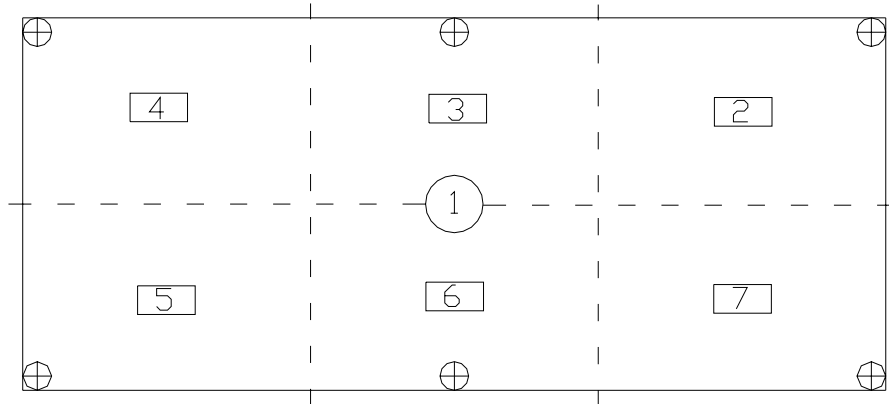

⊕ identifies support point (lever chair, load cell stand, flexure element, etc.)

**Forklift or Hand-Truck Scales**

- Using the appropriate loading pattern below, perform the same tests as above. Weights should be placed upon the largest pallet typically lifted by the forklift or hand-truck. If the forks are adjustable, repeat test at both minimum and maximum fork spacing.

Field Inspection Manual	Part: 3-STP	Section: 15	Page: 4 of 12
Non Automatic Weighing Devices	Issued: 2008-10-01	Revision Number: 4	

**STP-15      ECCENTRICITY TEST**

- Due to the nature of these pieces of equipment, extreme care must be taken to ensure that the stability of the forklift or hand-truck is not compromised during the test. Testing should always be done with the forks in the lowered position.

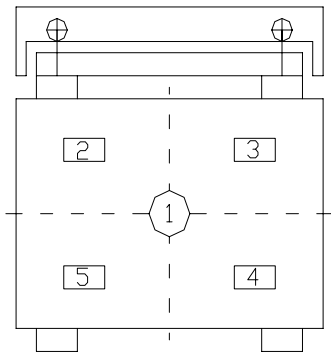

**Forklift - all configurations**

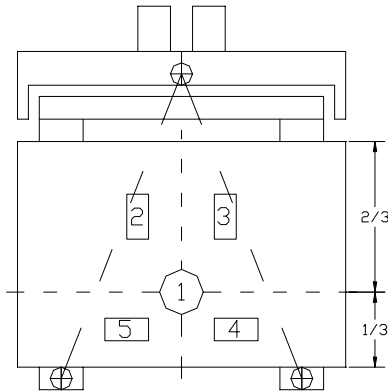

**Hand truck - 3 supports**

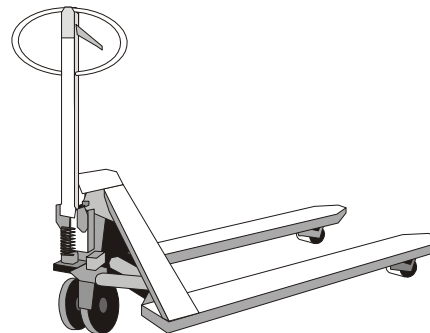

Field Inspection Manual	Part: 3-STP	Section: 15	Page: 5 of 12
Non Automatic Weighing Devices	Issued: 2008-10-01	Revision Number: 4	

## STP-15 ECCENTRICITY TEST

### Monorail Scales

- Zero the device.
- Apply a rolling load corresponding to the usual rolling load, the heaviest and the most concentrated one which may be weighed, but not exceeding 80% of **Max** at different points of the Load Receiving Element.
- Record the indications.

During this test, observe the rail to detect any inappropriate motion, deflection, binding or friction that could adversely affect the scale performance.

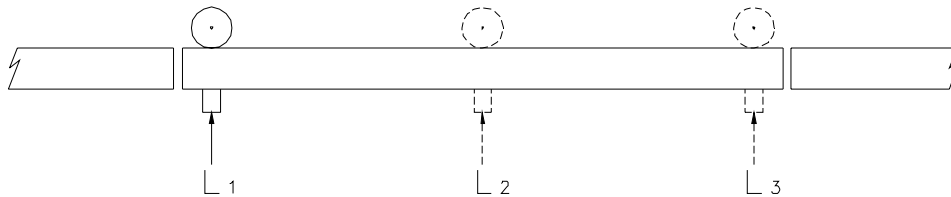

### Tank or Hopper Scales

(devices subject to minimal off-center loading)

- Zero the device.
- Use a test load of at least 10% of **Max** without exceeding 25% of **Max**. Apply the test load to each point of support. Care must be taken to keep the center of gravity of the load between the supporting points to prevent cantilevering the scale.
- Record the indications.

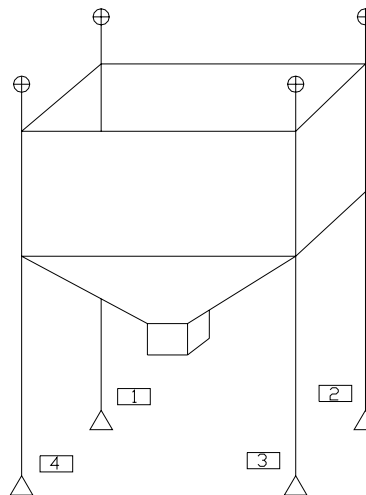

Field Inspection Manual	Part: 3-STP	Section: 15	Page: 6 of 12
Non Automatic Weighing Devices	Issued: 2008-10-01	Revision Number: 4	

## STP-15 ECCENTRICITY TEST

### Section / Shift Tests - Vehicle Scales

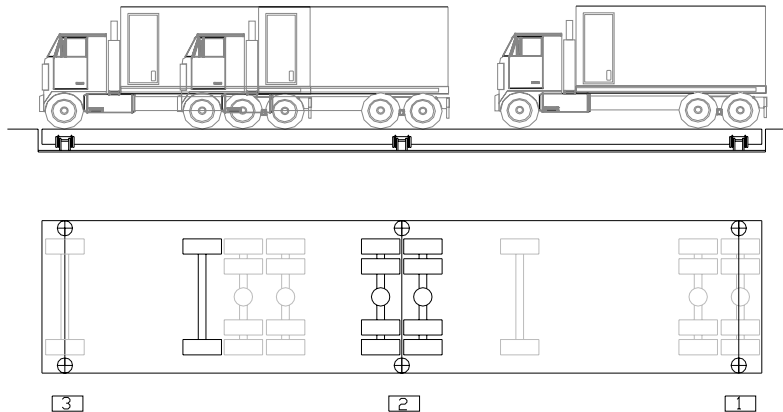

**Vehicle Scale - 3 section**

### Maximum Concentrated Load

The heaviest axle (or set of axles) weight of the vehicle used must not be greater than 75% *Max* in the case of a two section scale, and not greater than 50% *Max* in the case of a scale with more than two sections. Subject to the above maximum, the heaviest and most concentrated load available should be used.

**WARNING:** Tracked vehicles should never be used on a scale deck - rubber tire vehicles only.

### Procedure

- Zero the device
- Drive the loaded vehicle onto the weighbridge and position the center of the heaviest set of axles over the first section; record the indication.
- Move the concentrated load over the second section. Record the indications.
- Repeat the procedure for each of the other sections.
- Enter the weighbridge in the opposite direction and test each section again. At least two complete sets of shift tests should be conducted over each section of the scale. This is to determine the repeatability of the scale.

**NOTE:** The last section in each direction, before leaving the scale, cannot be adequately loaded with a typical test truck. The final stopping position should be just before the first set of axles leaves the weighbridge.

Field Inspection Manual	Part: 3-STP	Section: 15	Page: 7 of 12
Non Automatic Weighing Devices	Issued: 2008-10-01	Revision Number: 4	

**STP-15 ECCENTRICITY TEST**

**Shift Test - Deflection**

The concentrated load must also be placed between the sections to determine if any deflection of the deck or understructure is causing inaccuracies.

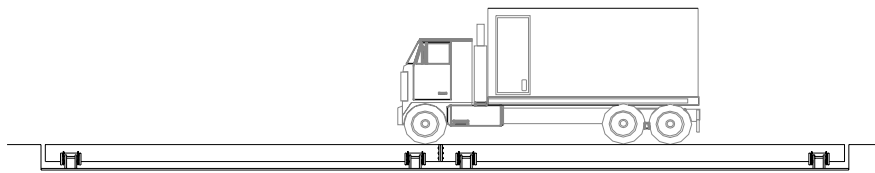

**Vehicle Scale - Deflection**

**NOTE:** When using a loader to conduct a shift test, the center-of-gravity (CoG) should be positioned over the load cell(s). This position will change depending upon the configuration of the machine. In addition, loaders, when used as strain or shift test loads should have their buckets / grapples in lowered positions if possible. This lowers the CoG and reduces the “sail” effect from the wind.

**Shift Test - Wide Deck**

If the width of the weighbridge exceeds 3 metres (or when the inspector deems it necessary), perform a first series of tests with the vehicle shifted on the right side of the deck and then shifted to the left side.

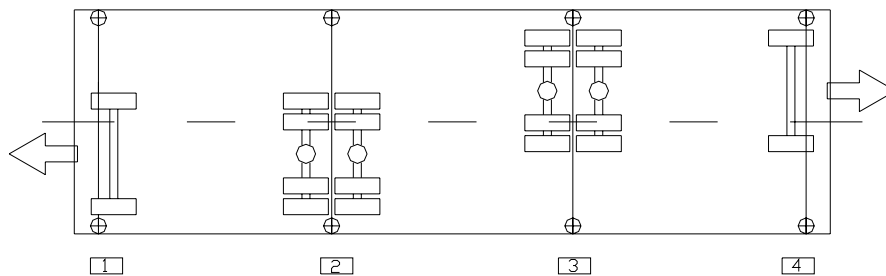

**WARNING:** Wide Deck shift test should not be attempted on wooden deck scales if the test means driving the vehicle off of the longitudinal timbers intended to support the tires. The transverse mounted decking may not have adequate strength to support the concentrated load of the vehicle.

Field Inspection Manual	Part: 3-STP	Section: 15	Page: 8 of 12
Non Automatic Weighing Devices	Issued: 2008-10-01	Revision Number: 4	

**STP-15      ECCENTRICITY TEST**

**Shift Test - Modular & Multi-Deck Scales**

In the case of weighbridge made of modules (multi-deck vehicle scale), shift tests must also be conducted by placing the load so that it straddles the connection between the modules. At least one shift test is to be conducted on the scale with the test load placed on one side of the connection line of the module, then on the other side of the connection line. This test may be impractical if the modules are separated with non-sensing areas.

(See STP-26 Weighing Systems with Multiple Weighing Elements for more requirements)

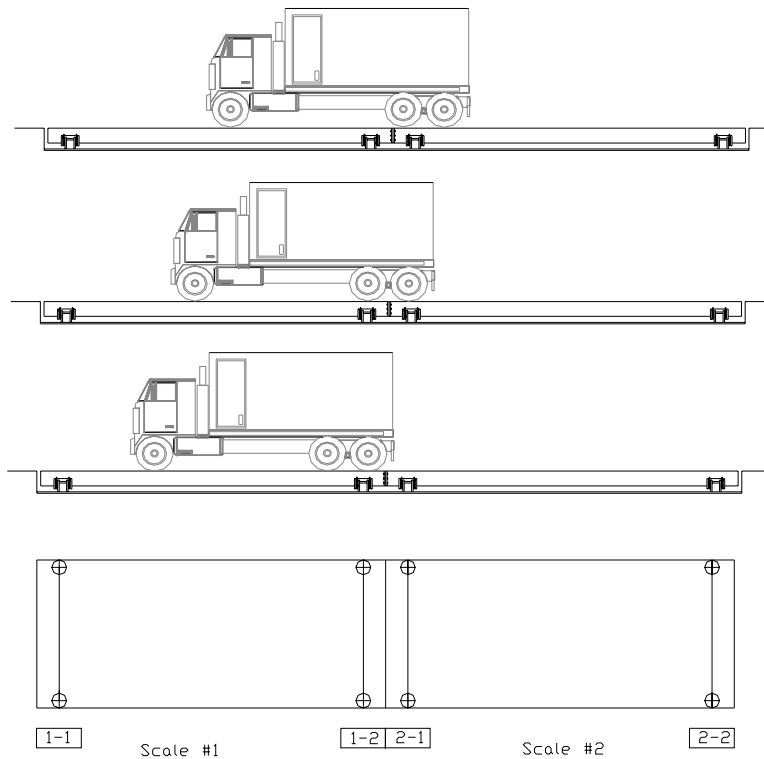

**Vehicle Scale - Modular**

Field Inspection Manual	Part: 3-STP	Section: 15	Page: 9 of 12
Non Automatic Weighing Devices	Issued: 2008-10-01	Revision Number: 4	

## STP-15 ECCENTRICITY TEST

### Vehicle Scale Mounted Side by Side.

#### PROCEDURE

Vehicle Scales mounted in non-traditional fashion. Often used for weighing of off-road mining equipment or large logging equipment. These scales usually consist of two scale decks mounted side by side, however other configurations are possible including a "T" configuration.

- Zero the device
- If possible, test eccentricity on each scale separately using the loading patterns for vehicle scales as above. Then continue with the following tests.
- Drive a loaded vehicle onto the weighbridge and position the center of the heaviest set of axles over the first support point/section; record the indication.
- Move the concentrated load over the second load point/section. Record the indications.
- Repeat the procedure for each of the other load points/sections.
- If possible, enter the weighbridge in the opposite direction and test each load point/section again.
- Testing should approximate normal use loading patterns as much as possible.

(See STP-26 Weighing Systems with Multiple Weighing Elements for more requirements)

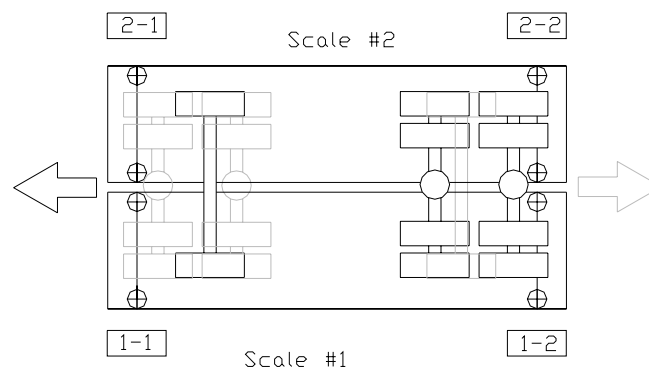

**Vehicle Scale - Side by Side**

#### INTERPRETATION OF THE RESULTS

The difference between the results for different positions of the load must not exceed the absolute value of the In-Service Limit of Error for that load.

Each individual result must also be within the applicable limits of error for the test.

#### Section / Shift Tests - Railroad Scales

Loading patterns to be the same as for vehicle scales. Each section and each end shall be loaded in turn. The tests shall be run in both directions.

Field Inspection Manual	Part: <b>3-STP</b>	Section: <b>15</b>	Page: <b>10 of 12</b>
Non Automatic Weighing Devices	Issued: <b>2008-10-01</b>	Revision Number: <b>4</b>	

**STP-15            ECCENTRICITY TEST**

Maximum Concentrated Load

The bogey weight of the test car used must not be greater than 75% Max in the case of a two section scale, and not greater than 50% Max in the case of a scale with more than two sections. Subject to the above maximum, the heaviest and most concentrated load available should be used - usually a suitable short rail test car will be available for this test. Alternately, sections can be run with a track-mobile if a heavy enough one is available.

Procedure

- Zero the device
- Position the loaded test load onto the weighbridge centered over the first section. Set the brakes lightly on the test car and uncouple and remove the power unit (track-mobile, locomotive, etc.) if used. Record the indication.
- Repeat the procedure for each of the other sections.
- Enter the weighbridge in the opposite direction and test each section again. At least two complete sets of shift tests should be conducted over each section of the scale. This is to determine the repeatability of the scale.

**WARNING:** Do not allow a locomotive to enter a scale deck unless authorized by the owner of the scale.

Field Inspection Manual	Part: <b>3-STP</b>	Section: <b>15</b>	Page: <b>11 of 12</b>
Non Automatic Weighing Devices	Issued: <b>2008-10-01</b>	Revision Number: <b>4</b>	

**STP-15          ECCENTRICITY TEST**

**Use of Hydraulic Jacking Beams**

The use of weight truck hydraulic jacking beams or other weight concentrating apparatus is **PROHIBITED** for safety reasons. Likewise, stabilizers on crane/boom trucks should not be lowered onto scale decks unless adequate provision is made to distribute the concentrated load. Use of these stabilizers on scale approaches may also require some type of weight distribution measures to be implemented.

**Use of Motorized Mobile Weight Carts**

Motorized Mobile Weight Carts may be used to test vehicle scales only under the following conditions:

- a) The cart must follow the same loading patterns and restrictions applicable to the use of any other mobile concentrated load such as a truck or loader. The cart must only be moved lengthwise on the deck. The cart must only be positioned on areas of the deck designed to support a vehicle. In no case shall the cart be positioned on wooden aprons or transversely mounted decking timbers outside of the area normally used to support a vehicle. Carts should not normally be used on other platform scales.
- b) Extreme caution shall be taken when moving the cart on or off of the scale. Ensure that the approaches are of sufficient strength to handle the concentrated load and that the transition is smooth to facilitate cart movements.
- c) The cart must be designed and loaded so as to exert a concentrated loading of no more than 14 kg/cm<sup>2</sup> or 140 000 kg/m<sup>2</sup> (200 lb/in<sup>2</sup>).

$$[\text{Cart Weight kg (lb) + Standards kg (lb)}] / [\# \text{ of Tires} \times \text{Contact Area cm}^2 \text{ (in}^2\text{)}]$$

where:

- Cart Weight      = total weight of cart in kg (lb).
- Standards        = total weight of standards in kg (lb).
- # of Tires        = number of Tires contacting the road surface.
- Contact Area    = total contact area of one tire in cm<sup>2</sup> (in<sup>2</sup>).
- = width of tire in cm (in) x length of loaded contact patch in cm (in).

Field Inspection Manual	Part: 3-STP	Section: 15	Page: 12 of 12
Non Automatic Weighing Devices	Issued: 2008-10-01	Revision Number: 4	

**STP-15            ECCENTRICITY TEST**

**REVISION**

Rev 4.

- harmonize load requirements and patterns for scales with not more than 4 points of support.
- remove note from railroad scale test procedure.
- update cart procedures to allow movement on/off load receiving element while loaded.

Rev 3.

- added motorized cart requirements and load restrictions.
- added railroad scale test procedures.
- added minimum recommended test loads for vehicle scale eccentricity testing.
- added maximum recommended length of test load for vehicle scale eccentricity testing.
- change vehicle scale graphic from 4 section to 3 section to facilitate test load length depiction.
- added rationale for applying test load to center or number 1 position on platform scales.
- bulletin reorganized to group common inspection types.
- correct references to *Specifications Relating to Non-Automatic Weighing Devices (1998)*.

Rev 2.

- modified & simplified forklift / hand truck loading requirements.

Rev 1.

- change reference from "load cell" to "support point" to cover all scale types.
- added eccentricity drawing for Forklift, single support.
- corrected number of support points reference in platform scales ( $\leq 4$ ).
- added procedure for platform scales with more than four support points.
- added procedure for "side by side" deck vehicle scales.

<b>Field Inspection Manual</b>	Part: <b>3-STP</b>	Section: <b>16</b>	Page: <b>1 of 1</b>
<b>Non Automatic Weighing Devices</b>	Issued: <b>2004-03-01</b>	Revision Number: <b>Original</b>	

## **STP-16 REPEATABILITY**

### **REFERENCE**

Sections 11 and 12 of the Non Automatic Weighing Devices Specifications.

### **PURPOSE**

The purpose of this test is to determine if the scale can repeat, within prescribed limits of error, the same indication when the same load is reapplied to the scale several times, in approximately the same manner.

### **PROCEDURE**

Use a test load or test quantity of approximately 50% of Max. Usually, the load that was used for the eccentricity test will be used.

- Apply the test load to the weighing element and note the indication.
- Remove the entire load.
- Repeat this test at least two more times by applying the load to approximately the same area of the weighing element and in the same manner.
- Note the indications obtained.

**NOTE:** If several increasing and decreasing load tests are performed, the repeatability of the scale may be determined by comparing the results for each individual load of increasing and decreasing tests.

### **INTERPRETATION OF RESULTS**

The device meets the requirements if the difference between the results obtained, for the same load, do not exceed the absolute value of the in-service limits of error for that load.

Each individual result must also be within the prescribed limits of error.

### **REVISION**

Original document

Field Inspection Manual	Part: 3-STP	Section: 17	Page: 1 of 3
Non Automatic Weighing Devices	Issued: 2008-01-01	Revision Number: 2	

## STP-17 AGREEMENT OF REGISTRATION

### REFERENCE

Sections 18 of the *Specifications Relating to Non-automatic Weighing Devices (1998)*.

### PURPOSE

The purpose of this test is to establish the accuracy and reliability of communication among all means of indication and registration of a device. The means of indication and registration include primary and secondary indications, printers, computers and other recording means directly interfaced to the primary weight indicating element.

### PROCEDURE

- Zero the device.
- Verify the agreement between indications and registrations at zero load (or the minimum load that can be printed).
- Apply a load to the load receiving element and print.
- Repeat the test with different loads (e.g. close to zero load, at mid capacity, close to capacity).
- Verify the agreement of all indications and registrations, including the printouts.

### INTERPRETATION OF RESULTS

The device complies with the requirements when the quantities indicated and/or printed are in agreement within the following limits:

- Electronic digital values having the same actual scale interval **d** must be in exact agreement;
- Analogue values having the same interval must agree within 0.25 times the value of the interval;
- Mechanical digital values, electronic digital values having different intervals, and combined digital and analogue values must agree within 0.6 times the value of the largest interval.

Calculated and derived values must be accurate and be based upon the correct measured values.

The agreement of registration requirements are applicable when indications and registrations of weight values are in the same weighing mode (net, gross or tare). Indicated and registered net weights must therefore agree, within the above limits, as must indicated and registered gross weights and indicated and registered tare weights. However, this requirement is not intended to apply when a device indicates a gross weight and prints a net weight, as is the case with some POS systems.

### POINT OF SALE (POS) SYSTEMS

POS systems used at retail grocery front end checkouts may have built in tare features. These systems are not designed with conventional weight displays when tare is in use. In order to ensure accurate measurement and allow tare to be taken, the indication of a gross weight and the printing of a net weight is acceptable on these POS systems.

<b>Field Inspection Manual</b>	Part: <b>3-STP</b>	Section: <b>17</b>	Page: <b>2 of 3</b>
<b>Non Automatic Weighing Devices</b>	Issued: <b>2008-01-01</b>	Revision Number: <b>2</b>	

### **STP-17 AGREEMENT OF REGISTRATION**

POS systems may use any compatible secondary display (customer pod), to meet customer visibility requirements, as long as the display contains no metrological functions. Remote pod functions such as Zero are not considered metrological if they simply access an external parameter available on the approved weighing element.

### **NOT FOR DIRECT SALE APPLICATIONS**

The indication of a gross weight and the printing of a net weight is acceptable on systems used in "Not For Direct Sale" applications provided these systems are appropriately marked as per STP 3.7 *Markings*.

### **SCOREBOARDS AND SECONDARY DISPLAYS**

Scoreboards and other secondary displays must meet all of the requirements of primary displays including Gross, Net, Tare, Zero, Units of Measure, etc.

Newer Scoreboards (often referred to as Smart Scoreboards) may be capable of providing other features to the user of the device, including axle weighing, stop/proceed indicators, etc. Agreement between these scoreboards and the primary indicating element is not required during loading of the load receiving element. Once the load (i.e. the vehicle) is fully supported upon the load receiving element, agreement between the scoreboard and the primary indicating element must be restored. In addition, a return to zero indication must be provided to ensure the vehicle operator is aware the device is on zero before initiating a weighing cycle.

### **WEIGHT CLASSIFIERS**

The minimum interval of a recording device (i.e. a computer or printer) may be larger than the verification scale interval  $e$  of the weight classifier to which it is interfaced. In addition to the "agreement of registration" test described above, a test at the turning points of price ranges is performed to ensure that in all circumstances packages are classified accurately.

#### **Example - Weight classifier 10 kg x 5 g**

The interval of the printing device is 10 g  
Price ranges: 0 - 30 g (inclusive) = \$1.00  
Greater than 30 g = \$2.00

- Apply a load so that the weight indication is 25 g.
- Print the weight and price. The ticket may print 20 or 30 g, and must print \$1.00
- Apply a load so that the weight indication is 30 g.
- Print the weight and price. The printed weight must be 30 g, and the price must be \$1.00.

A weight of 40 g and a price of \$2.00 (second price range) may not be printed before the weight classifier indicates 35 g.

Field Inspection Manual	Part: <b>3-STP</b>	Section: <b>17</b>	Page: <b>3 of 3</b>
Non Automatic Weighing Devices	Issued: <b>2008-01-01</b>	Revision Number: <b>2</b>	

## STP-17 AGREEMENT OF REGISTRATION

### REVISION

#### Rev 2.

- remove 'verification scale' from agreement sections as auxiliary equipment does not have verification scale intervals.
- added Smart Scoreboard section.
- added and clarified POS agreement and use of secondary indicators (PODs).
- moved Not for Direct Sale applications to its own separate section (previously contained in POS systems).
- minor changes to terminology in Weight Classifier section.
- correct references to *Specifications Relating to Non-automatic Weighing Devices (1998)*.

#### Rev 1.

- elimination of the 10 x 1*d* load registration agreement test.

Field Inspection Manual	Part: 3-STP	Section: 18	Page: 1 of 2
Non Automatic Weighing Devices	Issued: 2008-01-01	Revision Number: 1	

## STP-18 BLANKING DISPLAY TEST

### REFERENCE

Sections 39 of the *Specifications Relating to Non-automatic Weighing Devices (1998)*.

### PURPOSE

Weighing devices shall not indicate or print weight values that exceed their maximum capacity (**Max** or **Max** + additive tare). If the units of registration can be changed without having to perform a re-calibration of the device (lb/kg switch), then perform individual tests for each and every unit which the device is capable of registering.

**Note:** For the purposes of the Display Blanking Test, a POS (Point of Sale System) is considered a computing scale and is subject to a maximum of **Max** + 9e.

### PROCEDURE

#### Span

- Stabilize and zero the device at nominal conditions;
- Load the device to its maximum rated capacity;
- Add loads until the device ceases to display weight values;
- Record the last weight value indicated (WI); attempt to print.
- Repeat the test for other units of measurement that the device can display.

$$WI \leq \text{Max} + (5\% \text{ Max or } 9e)$$

#### Tare

- Remove the load and set the device to zero.
- Enter a keyboard or a platter tare (T) equal to approximately 20% of **Max**.
- Add loads until the device ceases to indicate/print weight values.
- Record the last value indicated (WI).

$$WI + T \leq \text{Max} + (5\% \text{ Max or } 9e)$$

**NOTE:** Certain approved devices may incorporate a full or partial additive tare feature. Additive tare extends the weighing capacity of the scale. This must be taken into consideration when performing the blanking display test. (Consult the applicable Notice of Approval)

#### Zero - (To be performed if the scale can zero loads in excess of 4%)

- Remove the load and set the device to zero.
- Add a load in excess of 5% of **Max** (e.g. 20%); zero that load (ZI).
- Add loads until the device ceases to display/ print weight values.
- Record the last value indicated (WI)
- If the scale limits the amount that can be zeroed by the semi-automatic zero setting mechanism but the operation can be repeated several times, zero the maximum weight possible equal to or under 5% of **Max**.

$$WI + ZI \leq \text{Max} + (5\% \text{ Max or } 9e)$$

Field Inspection Manual	Part: 3-STP	Section: 18	Page: 2 of 2
Non Automatic Weighing Devices	Issued: 2008-01-01	Revision Number: 1	

## STP-18 BLANKING DISPLAY TEST

### INTERPRETATION OF RESULTS

The device is deemed to comply with the requirement if it can not display or print weight values in excess of:

- **9 verification scale intervals e**, for Point of Sale Weighing Systems (POS) and computing scales other than weight classifiers and postal scales and is the preferred option for all non-automatic weighing devices; or
- **105% of Max**, for other non-automatic weighing devices.

When over capacity, the device registration must blank within prescribed limits, or display a clear message that cannot be mistaken for a weight value.

### Acceptable Solutions:

Among others, the following means of indicating overcapacity are acceptable:

- a row of "EEEEEEE"
- a blank registration
- the word "OVERCAPACITY"

Among others, the following means of indicating overcapacity are not acceptable:

- displaying a flashing eight
- displaying a row of zeros or eights
- any other indication which may possibly be mistaken for a weight value.

The same rules apply to printed information.

### REVISION

Rev 1.

- reference to +9e being preferred blanking point for all Non-Automatic Weighing Devices (OIML R76 4.2.3)
- clarify reason for some unacceptable display options.
- change reference from 'scale' to 'non automatic weighing device'.
- change various references to **d** and/or scale division to verification scale interval or **e**.
- correct references to *Specifications Relating to Non-automatic Weighing Devices (1998)*.

<b>Field Inspection Manual</b>	Part: <b>3-STP</b>	Section: <b>19</b>	Page: <b>1 of 1</b>
<b>Non Automatic Weighing Devices</b>	Issued: <b>2004-03-01</b>	Revision Number: <b>Original</b>	

## **STP-19 MOTION DETECTION TEST**

### **REFERENCE**

Sections 45 of the Non Automatic Weighing Devices Specifications.

### **PURPOSE**

Electronic devices must have motion detection capability to prevent the device from zeroing (semi-automatic zero) or taring (platter or keyboard tare) a part of the load when the semi-automatic zero or tare key is activated while a load is added, changed or removed from the platter.

Electronic devices equipped with a printer (or that have connections for a printer) must have motion detection capability to prevent the device from printing values before the weight display has stabilized. This reduces the possibility of recording incorrect weight values.

This test is to determine if printing, zeroing, or the entry of a tare is inhibited when motion is detected.

### **PROCEDURE**

- Place a load within the weighing range on the platter and allow time for the indication to stabilize.
- Induce a motion to the scale indications to a peak magnitude of at least 10 e (amplitude);
- While disturbing the weight indication, activate the SAZSM and allow the oscillations to settle out. The scale may eventually zero the load or may reject the command.
- While disturbing the load, attempt to activate the tare button (platter tare). The scale may eventually tare the load on the platter, or reject the command.
- While disturbing the load, attempt to print. The scale may print a weight or reject the command.
- Repeat the test two or three times for small loads ( near zero) and loads near capacity.

### **INTERPRETATION OF RESULTS**

The device complies with the requirements if zeroing, taring or printing the load on the platter is prevented, or is within 1 e (verification scale interval) for scales that have a maximum capacity of up to 2 000 kg (5 000 lb); or 3 e (verification scale intervals) for scales of more than 2 000 kg (5 000 lb). Printed and displayed weight values must be within the prescribed limits of error.

### **REVISION**

Original document

<b>Field Inspection Manual</b>	Part: <b>3-STP</b>	Section: <b>20</b>	Page: <b>1 of 2</b>
<b>Non Automatic Weighing Devices</b>	Issued: <b>2004-03-01</b>	Revision Number: <b>Original</b>	

## **STP-20 ACCURACY OF PRICE COMPUTATION**

### **REFERENCE**

Sections 19, 31, 46, 47, 66 and 67 of the Non Automatic Weighing Devices Specifications.

### **PURPOSE**

This test is to ensure that price computations are accurate and properly rounded off to the nearest cent; that printing devices provide the minimum required information; and that the scale has been configured in accordance with the requirements. This test is performed on any computing scales and POS systems.

### **BEFORE PERFORMING THE TEST, THE INSPECTOR ENSURE THAT:**

- the unit price is printed when the total price is printed;
- the displayed and recorded monetary values are readable, clear and defined by appropriate words or symbols.

### **DEVICES INTENDED FOR DIRECT SALE TO THE PUBLIC**

- the device displays the unit price when the total price is displayed;
- the device can only display unit prices on the basis of price/100 g and price/kg, when it measures in kilograms;
- the device can only display unit prices on the basis of price/pound when it measures in pounds.

### **OTHER REQUIREMENTS**

- the Total Price Display Unit has enough digits to indicate the computed total price on the basis of the maximum load that the device can weigh multiplied by the maximum value of unit price that it can accept;
- when the displayed weight is less than zero, the device is not capable of displaying or printing a computed total price. Place a small load on the platter, tare it and remove it from the platter. A negative weight value should be displayed. It should not be possible to display or print unit and total price values;
- when the device indicates an overcapacity condition, it can not display or print a weight or a computed total price;

### **FREE FLOATING WEIGHT AND TOTAL PRICE SIGNALS**

The displayed weight and total price is free floating; that is, when displayed unit price or weight is changed, the total price is changed accordingly.

### **ROUNDING RULES**

Total prices must be rounded off to the nearest cent. Perform the following test:

### **PROCEDURE**

- Apply several loads to the scale and enter different prices.
- With a calculator determine the correct values, round them off to the appropriate decimal, and compare them to the total price indicated by the scale.

<b>Field Inspection Manual</b>	Part: <b>3-STP</b>	Section: <b>20</b>	Page: <b>2 of 2</b>
<b>Non Automatic Weighing Devices</b>	Issued: <b>2004-03-01</b>	Revision Number: <b>Original</b>	

**STP-20 ACCURACY OF PRICE COMPUTATION**

The following are suggested loads and unit prices for computing scales:

<b>Test #</b>	<b>Net Weight</b>	<b>Unit Price</b>	<b>Total Price</b>	<b>Correct Indication</b>
A	0.01	\$4.54	\$0.045 40	\$0.05
B	0.01	\$4.55	\$0.045 50	\$0.05
C	0.01	\$4.90	\$0.049 00	\$0.05
D	0.01	\$5.10	\$0.051 00	\$0.05
E	0.01	\$2.50	\$0.025 00	\$0.02 or \$0.03
F	0.01	\$2.51	\$0.025 10	\$0.03
G	0.651	\$0.76	\$0.494 76	\$0.49
H	0.652	\$0.76	\$0.495 52	\$0.50

Apply the following rounding rule:

<b>Computed Results</b>	<b>Correct Indication</b>
0.020	0.02
0.021	0.02
0.022	0.02
0.023	0.02
0.024	0.02
0.025 0	0.02 or 0.03
0.025 1	0.03

**INTERPRETATION OF RESULTS**

The device complies with the requirements if all computed total prices are exact and rounded off as per the rule illustrated.

**REVISION**

Original document

<b>Field Inspection Manual</b>	Part: <b>3-STP</b>	Section: <b>21</b>	Page: <b>1 of 2</b>
<b>Non Automatic Weighing Devices</b>	Issued: <b>2004-03-01</b>	Revision Number: <b>Original</b>	

### STP-21 MATHEMATICAL AGREEMENT OF TARE, NET AND GROSS WEIGHTS

#### REFERENCE

Sections 19 of the Non Automatic Weighing Devices Specifications.

#### Purpose

There are two primary requirements concerning the printing of tare, net and gross weight values. First the recorded values must be mathematically correct and, second, the recorded values must be in agreement with the displayed values.

Two situations provide the greatest potential for non compliance with these requirements. One is when a platter tare is taken to the internal resolution of the scale and the scale indicates and records Gross, Tare and Net weights. In the second, a scale sums the analog signal from two or more weighing elements and the scale indicates and records Gross, Tare and Net weights.

#### PROCEDURE

The following procedure is performed on an electronic scale when a tare is taken to the internal resolution and the scale can display and/or print Gross, Tare and Net weights.

-Place a load on the platter that results in a scale indication that is just below the zone of uncertainty (or upper edge of the interval) and press the push-button tare key.

-Add more weight to the scale so the gross load is just above the zone of uncertainty (lower edge of the scale interval).

-Compare the indicated and recorded values for the Gross, Tare and Net weights. Values must be in mathematical agreement; indicated and printed values must be in agreement.

#### Example of possible non compliance on a 50 t x 10 kg:

Load perceived by the scale to the internal resolution	Displayed and Recorded Values
45 006 kg Gross <u>20 004 kg Tare</u>	45 010 kg Gross <u>20 000 kg Tare</u>
25 002 kg Net	25 000 kg Net

The following procedure is performed on an electronic scale that sums the analog signals from two or more weighing elements and the scale displays and prints Gross, Tare and Net weights.

-Place a load on each weighing element that results in a weight indication just below the zone of uncertainty (upper edge of the scale interval), or just above the zone of uncertainty (lower edge of the scale interval).

-Compare the indicated and recorded values for the Gross, Tare and Net weights. Values must be in mathematical agreement; indicated and printed values must be in agreement.

<b>Field Inspection Manual</b>	<b>Part: 3-STP</b>	<b>Section: 21</b>	<b>Page: 2 of 2</b>
<b>Non Automatic Weighing Devices</b>	<b>Issued: 2004-03-01</b>	<b>Revision Number: Original</b>	

**STP-21 MATHEMATICAL AGREEMENT OF TARE, NET AND GROSS WEIGHTS**

**Examples of possible non compliance on a 300 kg x 0.1 kg scale:**

	Load to internal resolution	Displayed values	Load to internal resolution	Displayed values
Scale 1	25.04 kg	25.0 kg	25.06 kg	25.1 kg
Scale 2	25.04 kg	25.0 kg	25.06 kg	25.1 kg
Sum	50.08 kg	50.1 kg	50.12 kg	50.1 kg

**INTERPRETATION OF RESULTS**

The device complies with the requirements if the displayed and printed values of Gross, Tare and Net weights are in mathematical agreement ( $N + T = G$ ); and displayed values agree with printed values.

**REVISION**

Original document

Field Inspection Manual	Part: 3-STP	Section: 22	Page: 1 of 5
Non Automatic Weighing Devices	Issued: 2004-03-01	Revision Number: Original	

## STP-22 OFF LEVEL EFFECT

### REFERENCE

Sections 19 of the Non Automatic Weighing Devices Specifications.

### PURPOSE

Section 21 of the specifications requires that portable or movable weighing devices, of a type other than suspended, measure within the prescribed limits of error when tilted up to 3 degrees in any direction. If they can not measure accurately when tilted, they must be equipped with permanent level indicating means.

The Laboratory performs off level tests on small devices that are submitted for approval. Consequently, field inspectors do not have to repeat the test on those devices.

Inspectors will perform an "off level" test on larger mobile floor scales that have not been evaluated by the Laboratory. This test is performed when the device is initially inspected.

On board weighing systems such as those used to deliver NH<sub>3</sub>, on-board weighing systems for waste, scales mounted on lift trucks, must be able to perform within applicable limits of error when tilted up to and at least 3 degrees.

### OFF LEVEL BY 3 DEGREES CALCULATION - EXAMPLE

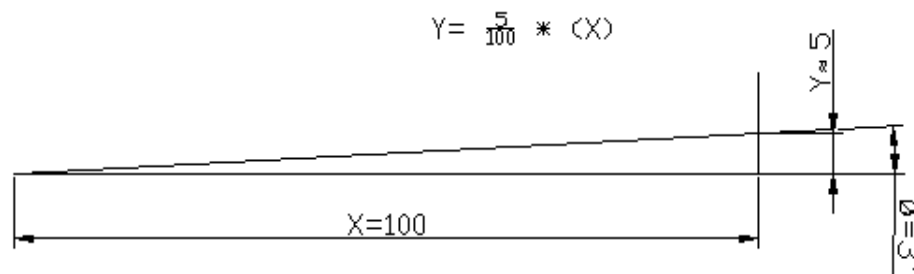

Measure the distance "x" between the two support points of the scale. Multiply the "x" value by  $\frac{5}{100}$  (0.05 or approx Tan 3°). The result is the elevation "y" at the support point.

### PORTABLE OR MOVABLE SCALES OTHER THAN ON BOARD SYSTEMS

Complete scales or load receiving elements other than on board weighing systems must meet one of the following conditions:

- the device weighs within LOE when off level by up to at least 3 degrees; or
- the device is equipped with a permanently installed level indicator as standard feature.

### IF THE DEVICE IS EQUIPPED WITH A SUITABLE LEVEL INDICATOR, THE FOLLOWING REQUIREMENT MUST BE MET:

- the level indicating means must be installed on a permanent section of the scale so that its reference will not change; must be easily readable and protected against damage;
- the level indicating means must be readily observable without disassembly that requires the use of tools;

Field Inspection Manual	Part: 3-STP	Section: 22	Page: 2 of 5
Non Automatic Weighing Devices	Issued: 2004-03-01	Revision Number: Original	

### STP-22 OFF LEVEL EFFECT

#### Clarification:

1. On small devices, the level indicating means may be placed under the platter (if the platter can be lifted easily) or at the back of the scale (if it can be readily observable).
2. A bubble level placed under the platform of a movable floor scale is not acceptable if the platform is relatively heavy and requires tools or assistance to be lifted up in order to access the level indicator.
3. The level indicating means must be permanently attached to a permanent part of the scale. It is not acceptable to attach the level indicator to the platter since it is removable.

-The level indicator must be sensitive. The following test must be performed to establish the suitability of the level indicator:

#### PROCEDURE

-Incline the Device Under Test (DUT) in one direction (arbitrary referred to as -x) up to:

- a) the point of limit where the level indicating means still indicates a level condition (see the following illustration); or
- b) at least 2/1000 (0.12 degree) whichever is greater.

-Set the device to zero if necessary; perform an increasing and decreasing load test. Record the results.

-Repeat the test for the other three inclinations (+x, -y, +y) (See the following illustrations).

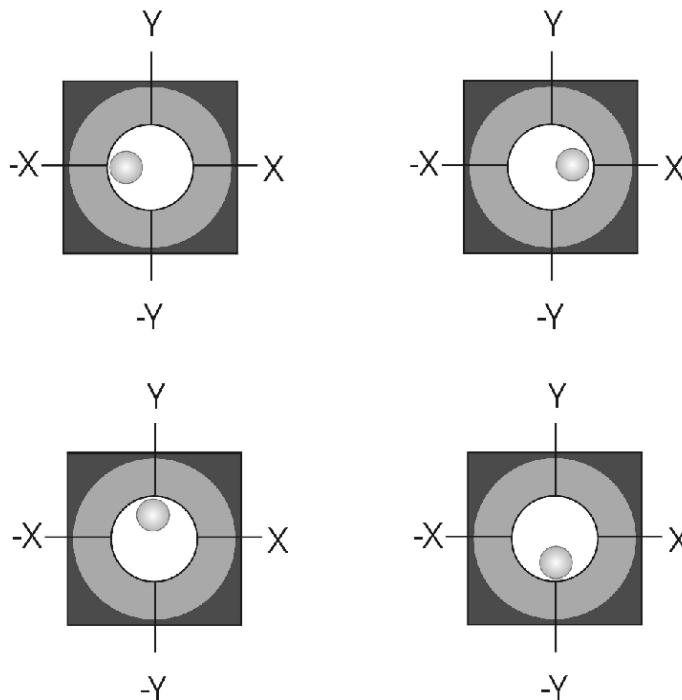

Field Inspection Manual	Part: 3-STP	Section: 22	Page: 3 of 5
Non Automatic Weighing Devices	Issued: 2004-03-01	Revision Number: Original	

### STP-22 OFF LEVEL EFFECT

#### INTERPRETATION OF RESULTS

The device meets the requirements if, at the limits of inclination in all four directions, it performs within applicable limits of error.

**NOTE :** Tests are performed with the heaviest load receiving element (when selectable) and up to Max or Max + additive tare, if applicable.

**IF THE DEVICE IS NOT EQUIPPED WITH A LEVEL INDICATOR PERFORM THE FOLLOWING “OFF LEVEL” TEST:**

#### PROCEDURE

-The procedure consists of inclining the device in the four directions (+x, -x, +y, -y) using a suitable support. The tests is performed when the device is off level by the lesser of:

- 3 degrees; or
- the maximum angle at which the device still provides an indication or registration.

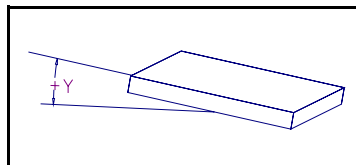
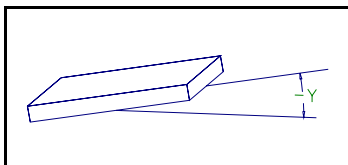
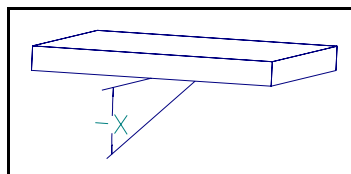
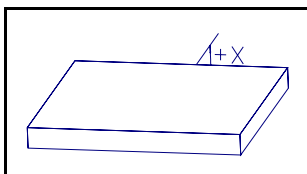

-For each of the four inclinations, set the device to zero and perform an increasing and decreasing load test.

#### INTERPRETATION OF RESULTS

The device meets the requirements if it performs within prescribed limits of error when off level in any direction.

**NOTE :** If the device can not perform within the prescribed limits of error, it must be equipped with a suitable, permanently installed level indicating means.

<b>Field Inspection Manual</b>	Part: <b>3-STP</b>	Section: <b>22</b>	Page: <b>4 of 5</b>
<b>Non Automatic Weighing Devices</b>	Issued: <b>2004-03-01</b>	Revision Number: <b>Original</b>	

## **STP-22 OFF LEVEL EFFECT**

### **ON-BOARD WEIGHING SYSTEMS SUCH AS SYSTEMS FOR FORKLIFT TRUCKS OR SIMILAR VEHICLES**

#### **Definition**

On board weighing system means weighing device designed to be an integral part of, or attached or secured to, the frame, chassis, lifting mechanism or bed of mobile equipment such as a truck, tractor, trailer or forklift

#### **Level Testing**

-With the vehicle resting on a level surface, visually inspect, checking for possible binding and additional items secured to the device that may have an effect on accuracy (e.g. mudflaps and fenders must be secured to the frame of the vehicle, not the device).

-Perform load discrimination tests near zero and at capacity; increasing and decreasing load tests; section/corner tests; repeatability; blanking at capacity and motion detection; return to zero; etc.. The device must perform within the prescribed limits of error.

#### **Off Level Test**

-Visually inspect the device while performing the following tests to ensure that the inclination does not cause a shift that may affect the device accuracy.

-Elevate the front or rear wheels to 3 degrees or the maximum inclination at which a weight indication is still provided, whichever is greater. Perform the tests described under "level testing" above, except the section and repeatability test.

-Elevate either the driver side or passenger side to 3 degrees or the maximum inclination at which a weight indication is still provided, whichever is greater. Perform the tests described under "level testing" above, except the section and repeatability test.

-Elevate a single rear wheel combination until the side to side inclination is 3 degrees or the point at which a weight indication is still provided, whichever is greater. This test causes the frame to twist and will reveal defects in poorly constructed devices. Perform the tests described under "level testing" above, except the section and repeatability test.

-Scales mounted on lift trucks (or similar vehicles) must blank their indications when the lift truck is moving, unless the scale can provide an accurate weight indication. Perform an accuracy (in-motion) test using different loads within the capacity range of the device. The test must simulate actual conditions of use.

<b>Field Inspection Manual</b>	Part: <b>3-STP</b>	Section: <b>22</b>	Page: <b>5 of 5</b>
<b>Non Automatic Weighing Devices</b>	Issued: <b>2004-03-01</b>	Revision Number: <b>Original</b>	

### **STP-22 OFF LEVEL EFFECT**

#### **INTERPRETATION OF RESULTS**

The device meets the requirements if :

- it provides a weight indication when off level up to at least 3 degrees, in any directions;
- it performs within the prescribed limits of error when off level by the larger of 3 degrees or the maximum angle at which it still provides a weight indication;
- it blanks its indications and prevent the recording of weight values when it ceases to perform within limits of error;
- in the case of a scale mounted on a lift truck, it provides an accurate weight indication while the lift truck is moving, or blanks its indications.

#### **REVISION**

Original document

Field Inspection Manual	Part: <b>3-STP</b>	Section: <b>23</b>	Page: <b>1 of 1</b>
Non Automatic Weighing Devices	Issued: <b>2004-03-01</b>	Revision Number: <b>Original</b>	

## **STP-23          Disturbance Test (EMI/RFI, Vibrations)**

### **REFERENCE**

Sections 29 and 57 of the Non Automatic Weighing Devices Specifications.

### **PURPOSE**

To ensure that the scale is adequately protected against environmental factors liable to adversely affect the performance of the device. In particular: vibrations, radio frequency interferences and magnetic field interferences could disturb the scale performance. Scales installed in industrial plants such as paper mills, foundries, mines, grain elevators, and large scales such as vehicle scales, railway scales are more subject to these disturbances.

### **CONSIDERATION**

Ensure that the activation of electrical and electronic equipment is done safely and in compliance with any safety requirements that may prevail.

### **PROCEDURE**

- Place a load on the load receptor.
- Activate any electrical or electronic surrounding equipment susceptible to generate magnetic fields or radio frequencies or other electrical waves (radio transmitter/receiver, transformers, electrical motors).
- Activate any surrounding equipment that are susceptible to generate vibrations (conveyors, engine of the truck resting on the weighing element).
- Observe the weight indication.

### **INTERPRETATION OF RESULTS**

The difference between the weight indication without the disturbance and the weight indication with the disturbance must not exceed 1 e (one verification interval). In this case, indications do not have to be within the LOE envelope.

### **Alternatives are:**

- the scale blanks its indications and prevents the printing of values during disturbances (stop working); or
- the scale provides an error message and prevents the weighing from proceeding during the disturbance; or
- the scale provides a weight indication that is so completely unstable that it could not be interpreted, or transmitted into memory or to a recording element as a correct measurement value.

**NOTE :**            the scale must be adequately protected against factors that can adversely affect its performance.

### **REVISION**

Original document

<b>Field Inspection Manual</b>	Part: <b>3-STP</b>	Section: <b>24</b>	Page: <b>1 of 2</b>
<b>Non Automatic Weighing Devices</b>	Issued: <b>2004-03-01</b>	Revision Number: <b>Original</b>	

## **STP-24 Weigh-in / Weigh-out Systems - Vehicle Scales**

### **REFERENCE**

Sections 31, 33 and 55 of the Non Automatic Weighing Devices Specifications.

### **PURPOSE**

A weigh-in/weigh-out system is typically a vehicle scale in which an inbound truck is weighed either loaded or empty, the inbound weight is stored, the truck is then emptied or loaded as the case may be, the outbound truck is weighed and the larger of the two weights (outbound or stored weight) is printed as the gross weight, the other printed as the tare weight and the difference computed as the net weight. Inbound weights, recalled weight values, and gross, tare and net weights must be identified to clearly document the transaction. The storage, recalling, and printing actions are limited so that they do not facilitate fraud.

This system does not retain inbound weights when the outbound weight is printed. The client's file (where inbound information is stored) is cleared for the next transaction.

In many cases, auxiliary equipment such as computers (software) are used to perform weigh-in/weigh-out operations. The following minimum requirements are essential to ensure that the system will not lead to measurement errors and will not facilitate the perpetration of fraud. Inspectors ensure that weigh in-out systems meet the requirements when the device is initially inspected.

### **REQUIREMENTS**

- Any inbound weight values must be recorded and automatically identified as such. If inbound weights are not printed at the time the weigh-in operation is performed, the inbound weight information must not be lost during a power interruption.
- The gross, tare and net weight values must be recorded (printed) in an automatic sequence when the outbound weight value is obtained.
- The recorded weight value is not required to be automatically identified as a gross weight value, provided that the other two weight values are clearly and automatically identified as net and tare.
- If a device can indicate and/or record in two and more weight units, all gross, tare and net weight values shall be automatically recorded in the same weight units. This condition must be met regardless which weight unit is being displayed.
- Any weigh-in/weigh-out weight values stored in the memory register shall automatically clear and not be retained in memory after a complete transaction of gross, tare and net has been recorded.
- Any recorded weighing value from the memory register shall be automatically identified and defined.
- Tare values shall not be stored as negative values. (Negative numbers shall not be accepted).
- Keyboard tare entries shall not be accepted into weigh-in/weigh-out memory registers.
- If the system is equipped with a tare memory register for weighing gross, tare and net weights separate from the weigh-in/weigh-out feature, the tare weight shall not interact with the weigh-in/weigh-out feature.
- The data processing system performing the weigh-in/weigh out operation shall only accept weight values when the scale indicator is in the gross weight mode, or give an error signal.

<b>Field Inspection Manual</b>	Part: <b>3-STP</b>	Section: <b>24</b>	Page: <b>2 of 2</b>
<b>Non Automatic Weighing Devices</b>	Issued: <b>2004-03-01</b>	Revision Number: <b>Original</b>	

**STP-24          Weigh-in / Weigh-out Systems - Vehicle Scales**

**REVISION**  
Original document

Field Inspection Manual	Part: 3-STP	Section: 25	Page: 1 of 4
Non Automatic Weighing Devices	Issued: 2008-01-01	Revision Number: 2	

## STP-25 Unattended Vehicle Scales

### REFERENCE

Sections 65 and 66 of the *Specifications Relating to Non-automatic Weighing Devices (1998)*.

### PURPOSE

Unattended vehicle scales are designed and installed to be used by vehicle operators who may not be properly trained to operate the scales. Hence, a certain level of automation is necessary to ensure accurate weighing. This procedure is to be used on scales that are designed and intended to function without an operator.

The purpose of this section is, therefore, to provide additional inspection procedures to be applied in conjunction with the procedures for attended vehicle scales.

**Note :** Inspections should be conducted with the assistance of a company representative responsible for the weighing system.

### REQUIREMENTS

The following requirements are in addition to those normally applicable to vehicle scales. Please note that the numbering of the following sections correspond to the numbering used in the *Approval Evaluation Manual - Non Automatic Weighing Devices*. A vehicle scale used in an unattended operation must:

25.1 - have an automatic means to indicate to the vehicle operator that the device has returned to zero. A system of red and green lights or a secondary weight display that is easily visible from the position where the vehicle stops, before driving onto the load receiving element, may be adequate;

25.2 - have an automatic means to prevent the indication and printing of a weight if the device has not returned to zero before the vehicle proceeds onto the scale;

25.3 - have an automatic means to prevent the indication and printing of a weight if the vehicle is not entirely supported by the load receiving element. The use of optical or magnetic detection devices, or gates, may be adequate;

25.4 - include a printer that, *upon demand*, automatically prints the gross weight and if a total price is recorded, the unit price; and

25.5 - be provided with a means for sealing the adjustment mechanisms of the vehicle detectors. This is critical since these detectors are used to validate/invalidate transactions.

Field Inspection Manual	Part: 3-STP	Section: 25	Page: 2 of 4
Non Automatic Weighing Devices	Issued: 2008-01-01	Revision Number: 2	

## STP-25 Unattended Vehicle Scales

### PROCEDURES - AUTOMATIC ZERO INDICATION

#### Purpose

The purpose of this procedure is to ensure that the device has an automatic means to reset the indicating element to zero and indicate to the vehicle operator that the device has returned to zero, before the vehicle is authorized to proceed onto the scale.

- Ensure that the device is at zero load indicated.
- Place a load equivalent to 2e (verification scale intervals) on the load receiving element (e.g. 20 kg for a scale with 10 kg scale intervals).
- Using a vehicle, initiate the weighing cycle (if possible, use the same type of vehicle as that which will be used for trade transactions).
- Ensure that the indicator returns to zero and an indication of this is automatically provided to the vehicle operator before the vehicle is authorized to move onto the load receiving element.

### INTERPRETATION OF RESULTS

The system must provide the vehicle operator an indication that the vehicle may proceed onto the load receiving element only if the indicating element is at zero. This indication may be in the form of a gate, traffic light, etc.

### PROCEDURE - INDICATOR/PRINTER INHIBITION - OUT OF ZERO CONDITION

#### Purpose

The purpose of this procedure is to ensure that the device has an automatic means to prevent the indication and printing of a weight if the device has not returned to zero before the vehicle proceeds onto the load receiving element.

- Ensure that the device is at zero load indicated.
- Place a load equivalent to at least 2e (verification scale intervals) on the load receiving element (e.g. at least 20 kg for a scale with 10 kg scale intervals).
- Have a vehicle drive directly onto the load receiving element without waiting for the scale to return to zero.
- Attempt to print a weight ticket.

### INTERPRETATION OF RESULTS

The indicating element must not provide a weight indication, or if it is not feasible to prevent weight indication, there must be a suitable warning to the vehicle operator that the transaction is not acceptable (error message on computer screen, etc.). In either case, the printer must not print a weight ticket.

<b>Field Inspection Manual</b>	Part: <b>3-STP</b>	Section: <b>25</b>	Page: <b>3 of 4</b>
<b>Non Automatic Weighing Devices</b>	Issued: <b>2008-01-01</b>	Revision Number: <b>2</b>	

## **STP-25 Unattended Vehicle Scales**

### **PROCEDURE - PERFORMANCE OF THE VEHICLE DETECTORS**

#### **Purpose**

The purpose of this procedure is to ensure that the device has an automatic means to prevent the indication and printing of a weight if the vehicle is not entirely supported by the load receiving element.

- Using a vehicle, initiate the weighing cycle and wait for the signal (e.g. light) to proceed onto the load receiving element (if possible, use the same type of vehicle as that which will be used for trade transactions).
- Position the vehicle on the load receiving element and note the weight indication.
- Slowly advance the vehicle until it comes off of the load receiving element and the weight indication decreases.
- Attempt to print a weight ticket.
- Run the same test by driving the vehicle onto the load receiving element from the opposite direction.

### **INTERPRETATION OF RESULTS**

The indicating element must not provide a weight indication when the vehicle is not entirely supported by the load receiving element, or if it is not feasible to prevent weight indication, there must be a suitable warning to the vehicle operator that the transaction is not acceptable (error message on computer screen, etc.). In either case, the printer must not print a weight ticket.

### **PROCEDURE - DEACTIVATION OF THE VEHICLE DETECTORS**

#### **Purpose**

The purpose of this procedure is to ensure that the automatic means of preventing the indication and printing of a weight, when a vehicle is not entirely supported by the load receiving element, remain active after their initial activation.

- Using a vehicle, initiate the weighing cycle and wait for the signal (e.g. light) to proceed onto the load receiving element (if possible, use the same type of vehicle as that which will be used for trade transactions).
- Position the vehicle on the load receiving element and note the weight indication.
- Have the vehicle advance slowly until the front axle is off the load receiving element.
- Have the vehicle slowly back up until it is again fully supported by the load receiving element.
- Advance the vehicle until the front axle is once again off the load receiving element.
- Attempt to print a weight ticket.
- If the system has a "cancel" or "back-up" option, ensure that it does not affect nor neutralize the operation of the vehicle detectors.

### **INTERPRETATION OF RESULTS**

The indicating element must not provide a weight indication when the vehicle is not entirely supported by the load receiving element, or if it is not feasible to prevent weight indication, there must be a suitable warning to the vehicle operator that the transaction is not acceptable (error message on computer screen, etc.). In either case, the printer must not print a weight ticket.

<b>Field Inspection Manual</b>	Part: <b>3-STP</b>	Section: <b>25</b>	Page: <b>4 of 4</b>
<b>Non Automatic Weighing Devices</b>	Issued: <b>2008-01-01</b>	Revision Number: <b>2</b>	

**STP-25          Unattended Vehicle Scales**

**REVISION**

Rev 2.

- added clarification to *Interpretation of Results* when preventing indication is not feasible, a warning message may suffice.
- correct reference to *Specifications Relating to Non-automatic Weighing Devices (1998)*.

Rev 1.

- modified section 25.4 - added *upon demand* to requirement.

Field Inspection Manual	Part: 3-STP	Section: 26	Page: 1 of 7
Non Automatic Weighing Devices	Issued: 2008-01-01	Revision Number: 1	

## STP-26 Weighing Systems With Multiple Load Receiving Elements

### REFERENCE

Sections 30, 31 33, 34 et 55 of the *Specifications Relating to Non-automatic Weighing Devices (1998)*.

### PURPOSE

A weight indicator and/or printer may be interfaced to more than one weighing element provided that the weighing system is designed to ensure accuracy of transactions, and to prevent inadvertent errors or fraud.

Two basic types of Multiple Deck Weighing Systems are used in trade:

Type 1 - a system where only one load receiving element (LRE) can be selected and operate at a time (multi-plex); and

Type 2 - a system where all load receiving elements (LREs) can operate at the same time (multi-deck). In this system each load receiving element may have its own indicating element, all indicating elements being connected to a summing weight display; or the load receiving elements are connected to a multi-channel indicating element that can display simultaneously, or in alternance, weight values from the individual load receiving elements, and can also display the sum of the weights.

### REQUIREMENTS

#### TYPE 1 - ONE LOAD RECEIVING ELEMENT OPERATING AT A TIME (MULTI-PLEX SYSTEMS)

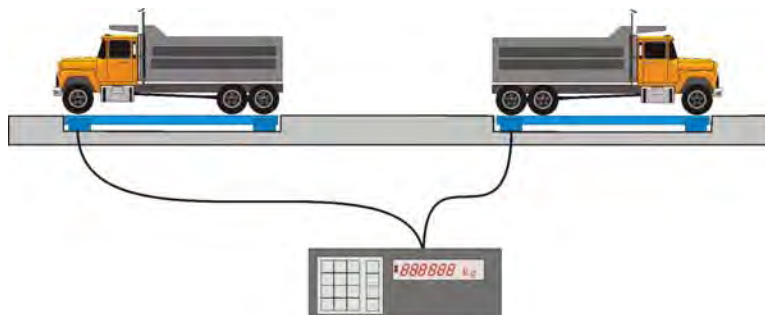

Two or more load receiving elements, designed to be used independently, are connected to a single Approved Multi Channel indicating element. This is a Multi-Plex Weighing System.

The following minimum requirements are in addition to the requirements normally applicable to vehicle scales.

- The Multi Channel indicating element may handle up to the maximum number of load receiving elements as described in the Notice of Approval.
- Load receiving elements may only be used separately (as shown) unless the indicating element is approved for summing separate channels (in which case the system is a Multi-Deck system and is covered in the next section - **Type 2**).

Field Inspection Manual	Part: 3-STP	Section: 26	Page: 2 of 7
Non Automatic Weighing Devices	Issued: 2008-01-01	Revision Number: 1	

## STP-26 Weighing Systems With Multiple Load Receiving Elements

- Load receiving elements must be clearly and permanently identified with the corresponding identification.
- The indicating element must automatically provide a clear and continuous indication of which load-receiving element is in use (i.e. Scale A, Scale B, Scale C, etc.). The indication must be visible from the operator's normal position.

**NOTE:** It is preferable to identify load receiving elements as Scale A, Scale B, etc. rather than Scale 1, Scale 2. Numbers that could be confused with weight indications are not acceptable.

- The indicating element must prohibit the use of any load receiving element that is not in use (only one load receiving element at a time).
- The printer must provide on the ticket, for each weighing, a clear registration indicating which load receiving element was used (Scale A, Scale B, etc.).
- When an operator-activated function (setting zero, entering a tare value, selecting or clearing a function, etc.) is performed on one particular load receiving element, functions or parameters of other load receiving elements must not be affected or altered.
- Unless the indicating element has independent AZTMs, one for each individual load receiving element, individual Centre-of-Zero indicators (annunciators), one for each load receiving element, must be provided. Centre-of-Zero indicators must provide a continuous signal (remain active) regardless of which load receiving element is selected.

### Inspection

- Each separate load receiving element and the indicating element is considered as a complete device and must be tested accordingly.

### STARS/PICASSO Coding

- Each load receiving element shall be listed as a separate device and must be identified in some manner to prevent confusion (Scale A, Scale B, etc.). The same indicating element shall be listed for each of the load receiving elements and shall be identified as being multi-plexed. (See also *STARS/PICASSO Forms Completion Manual - Device Inspection section 20*).

### PROCEDURE

The purpose of this test is to ensure that when a setting is performed or a function is activated for one particular load receiving element, functions, entries or settings on the other load receiving elements are not changed or altered.

- Zero each individual load receiving element.
- Place a small load (e.g. 5e) on one of the load receiving elements; zero that load receiving element; verify that the zero balance condition of the other load receiving elements has not changed.
- Enter a platter or keyboard tare for each load receiving element.
- Clear or change the tare value on one load receiving element.
- Verify that tare values of the other load receiving elements have not changed.
- Place different combinations of loads on the load receiving elements; ensure that the weights are correctly and accurately indicated; ensure that the printed weights agree with indicated weights and are properly identified.

Field Inspection Manual	Part: 3-STP	Section: 26	Page: 3 of 7
Non Automatic Weighing Devices	Issued: 2008-01-01	Revision Number: 1	

## STP-26 Weighing Systems With Multiple Load Receiving Elements

### INTERPRETATION OF RESULTS

The device complies with the requirements if:

- keyboard entries for one load receiving element (zero, tare, etc.) or the activation of the load receiving element selection key does not alter settings or values entered (zero, tare, etc.) of the other load receiving elements;
- the indicated and printed weights are accurate and identified as required; and
- the device meets the installation requirements mentioned above.

### TYPE 2 - WEIGHING SYSTEMS COMPOSED OF SEVERAL LOAD RECEIVING ELEMENTS (MULTI- DECK)

There are several different configurations that may be encountered. Each will have its own unique issues that must be addressed.

#### Scenario A

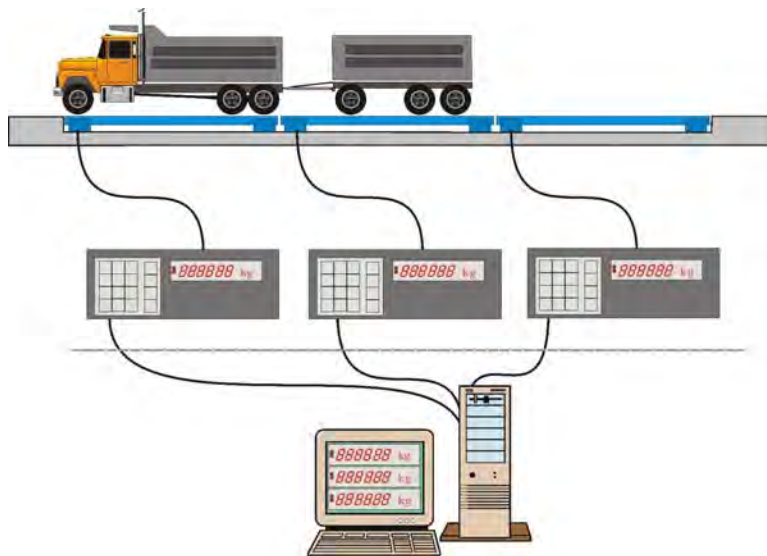

Two or more load receiving elements are connected to an equal number of Approved Single Channel indicating elements. This is a Multi-deck Weighing System. Output may be combined in a computer or other unapproved non-metrological indicator.

The following minimum requirements are in addition to the requirements normally applicable to vehicle scales.

- Each individual load receiving element must be approved.
- Each individual indicating element must be approved.

Field Inspection Manual	Part: 3-STP	Section: 26	Page: 4 of 7
Non Automatic Weighing Devices	Issued: 2008-01-01	Revision Number: 1	

## STP-26 Weighing Systems With Multiple Load Receiving Elements

- The individual load receiving elements must be installed adjacent to one another; they may be separated by non-sensing areas provided that there is year-round visual indication to distinguish the weighing elements and the non-sensing zone. Vehicles being weighed must still be fully scale borne.
- The actual scale interval  $d$  and unit of measurement must be the same for all means of indication in the system.
- The total zero range of the system must not exceed 4% of the sum of the inspected capacities of the individual load receiving elements.
- Each load receiving element must blank if the load on that element exceeds 105% of its inspected capacity.
- Overall system capacity is equal to the sum of the inspected capacities of the load receiving elements.
- The summing weight display must perform within applicable LOE.
- The summing weight display must have no calibration adjustment for individual indicating elements.
- The summing weight display must not indicate or record any weight when any one individual load receiving element exceeds 105% of its inspected capacity.
- The summing weight display must sum any tare entries in the individual indicating elements.
- The summing weight display must have a free floating signal used for summing the individual indicating elements.
- The summing weight display must be in exact agreement with the sum of all the individual indicating elements.

### Inspection

As per the appropriate Inspection Procedure Outline (IPO). Each deck shall be shift tested and a further shift test performed across the junction of any two adjacent decks (see also STP-15 *Eccentricity Test*).

### STARS/PICASSO Coding

Each load receiving element and indicating element shall be listed as a separate device starting from the leftmost load receiving element as viewed from the normal operators position (in case of any uncertainty, stand facing the load receiving element on the side where the signal cable or transverse lever exits the device). Each load receiving element shall be identified as forming part of the overall multi-deck system. (see also *STARS/PICASSO Forms Completion Manual - Device Inspection section 20*)

Field Inspection Manual	Part: 3-STP	Section: 26	Page: 5 of 7
Non Automatic Weighing Devices	Issued: 2008-01-01	Revision Number: 1	

## STP-26 Weighing Systems With Multiple Load Receiving Elements

### Scenario B

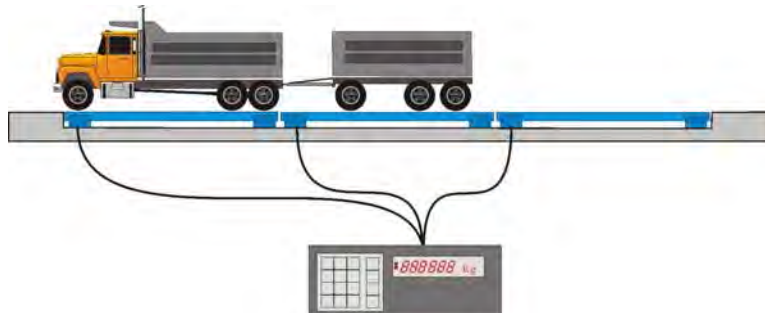

Two or more load receiving elements are connected to a single Approved Multi Channel indicating element. This is a Multi-deck Weighing System. The Multi-channel indicating elements may handle up to the maximum number of load receiving elements as described in the Notice of Approval. Load receiving elements may only be used in combination (as shown) if the indicating element is approved for summing separate channels, or if the approved indicating element provides a separate continuous display for each of the load receiving elements.

The following minimum requirements are in addition to the requirements normally applicable to vehicle scales.

- Each individual load receiving element must be approved.
- The indicating element must be approved for summing separate channels, or must have separate continuous displays for each of the load receiving elements.
- The individual load receiving elements must be installed adjacent to one another; they may be separated by non-sensing areas provided that there is year-round visual indication to distinguish the load receiving elements and the non-sensing zone. Vehicles being weighed must still be fully scale borne.
- The actual scale interval **d** and unit of measurement must be the same for all means of indication in the system.
- The total zero range of the system must not exceed 4% of the sum of the inspected capacities of the individual load receiving elements.
- The indicating element must perform within applicable LOE.
- The indicating element must not indicate or record any weight when any one load receiving element exceeds 105% of its inspected capacity.

Overall system capacity is equal to the sum of the inspected capacities of the load receiving elements. If any one load receiving element exceeds 105% of capacity, the entire system must blank.

### Inspection

As per the appropriate Inspection Procedure Outline (IPO). Each deck shall be shift tested and a further shift test performed across the junction of any two adjacent decks.  
(see also STP-15 *Eccentricity Test*)

Field Inspection Manual	Part: 3-STP	Section: 26	Page: 6 of 7
Non Automatic Weighing Devices	Issued: 2008-01-01	Revision Number: 1	

## STP-26 Weighing Systems With Multiple Load Receiving Elements

### STARS/PICASSO Coding

Each load receiving element shall be listed as a separate device starting from the leftmost load receiving element as viewed from the normal operators position (in case of any uncertainty, stand facing the load receiving elements on the side where the signal cable or transverse lever exits the device). The same indicating element shall be listed for each of the load receiving elements and shall be identified as being multi-channel. Each load receiving element shall be identified as forming part of the overall Multi-Deck system. (see also *STARS/PICASSO Forms Completion Manual - Device Inspection section 20*).

### Scenario C

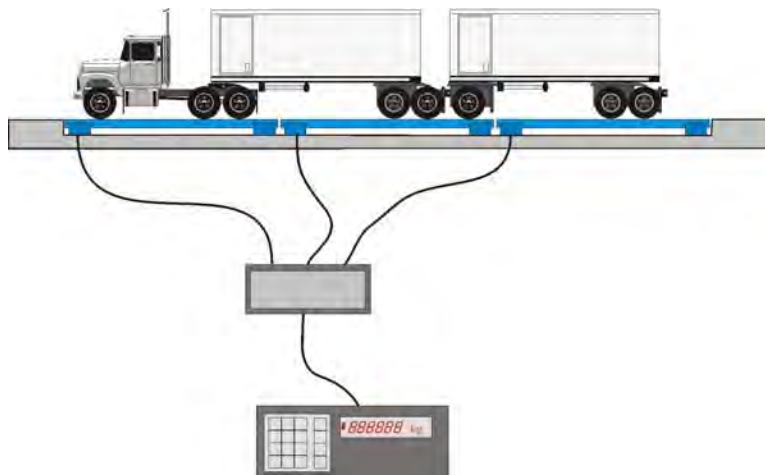

Two or more load receiving elements are integrated through a Junction Box and the aggregate signal is output to a single channel Approved indicating element. This is NOT considered a Multi-deck Weighing System.

The following minimum requirements are in addition to the requirements normally applicable to vehicle scales.

- Overall system capacity shall not exceed:
  - the capacity of the lowest capacity load receiving element in the case of all three or more section load receiving elements; and
  - one-and-one-half times (1.5 x) the capacity of the lowest capacity load receiving element in the case of all two section load receiving elements.
  - the lesser of one-and-one-half times (1.5 x) the capacity of the lowest capacity two section LRE and the capacity of the lowest capacity three or more section LRE's, in the case of mixed two and threes or more section LRE's.

Field Inspection Manual	Part: 3-STP	Section: 26	Page: 7 of 7
Non Automatic Weighing Devices	Issued: 2008-01-01	Revision Number: 1	

## STP-26 Weighing Systems With Multiple Load Receiving Elements

### Clarification:

- a 30 000 kg three section scale and a 40 000 kg three section scale are combined into a single longer deck scale. Overall capacity is equal to 30 000 kg.
- a 30 000 kg two section scale and a 40 000 kg two section scale are combined into a single longer deck scale. Overall capacity is equal 1.5 x 30 000 kg = 45 000 kg.
- a 30 000 kg two section scale and a 40 000 kg three section scale are combined into a single longer deck scale. 1.5 x 30 000 kg = 45 000 kg which is larger than the capacity of the three section scale at 40 000 kg. Therefore, overall capacity is 40 000 kg.

### Inspection

As per appropriate Inspection Procedure Outline (IPO). Each deck shall be shift tested and a further shift test performed across the junction of any two adjacent decks (see also STP-15 *Eccentricity Test*).

### STARS/PICASSO Coding

Each load receiving element shall be listed as a separate device starting from the leftmost load receiving element as viewed from the normal operators position (in case of any uncertainty, stand facing the load receiving elements on the side where the signal cable or transverse lever exits the device). The indicating element shall be listed second and the remaining load receiving elements, in order, are then listed as components of the system.

(see also *STARS/PICASSO Forms Completion Manual - Device Inspection section 20*)

### REVISION

#### Rev 1

- clarified and added examples of the possible configurations.
- added STARS/PICASSO coding information.
- ensure consistent terminology for *Load Receiving* and *Indicating Elements*.
- added inspection test criteria.
- correct references to *Specifications Relating to Non-automatic Weighing Devices (1998)*.

<b>Field Inspection Manual</b>	Part: <b>3-STP</b>	Section: <b>27</b>	Page: <b>1 of 3</b>
<b>Non Automatic Weighing Devices</b>	Issued: <b>2004-03-01</b>	Revision Number: <b>Original</b>	

## **STP-27 NH<sub>3</sub> On-Board Weighing Systems - Product Test**

### **REFERENCE**

All sections of the Non Automatic Weighing Devices Specifications dealing with performance requirements as well as section 21 of the Specifications.

### **PURPOSE**

This test may be performed on weighing systems mounted on a vehicle used to deliver Anhydrous Ammonia (NH<sub>3</sub>).

### **EQUIPMENT**

For the actual NH<sub>3</sub> Weighing System test, a suitable mass prover must be made available. To ensure that the mass prover is adequate for testing of the system, the following criteria must be met:

- the minimum graduation of the mass prover must be equal to or less than  $\frac{1}{5}$  of the limit of error (LOE) for the test load delivered from the Device Under Test (DUT).
- the capacity of the mass prover must be sufficient to ensure that a test load of greater than 500 times the minimum graduation (e) of the DUT may be measured.
- the mass prover must be considered acceptable by Measurement Canada for use as a piece of test equipment. Consult the Regional Gravimetric Specialist for more information.
- the mass prover must be calibrated and performing adequately. (Refer to the appropriate Mass Prover operators manual)
- The operator must be fully trained in use of the mass prover as well as handling of NH<sub>3</sub>. (Refer to Measurement Canada's Gravimetric Training for NH<sub>3</sub> Measuring Systems)

### **CONSIDERATIONS**

This procedure may be used to perform initial or subsequent inspection of on board weighing systems.

The limit of error applies to the weight of the product delivered. For example: the DUT displays 4 000 kg before the delivery, and 1 000 kg after the delivery. The limit of error applies to the 3 000 kg delivered.

Systems using multichannel capabilities for linearity correction of off angle conditions must be tested at least once in all channels. The deadload should be checked to ensure it is the same for all applicable channels. An approximate check can be done by noting the indicated value at level, then cycle the device through its inclination range and all channels; all channels should display the same value as when at level.

Where the liquid line is not attached to the live portion of the device, ensure this line is charged prior to beginning testing as it may have lost product due to leakage when not in use.

Order of conducting tests is not critical, angle tests can be conducted first if practicable.

### **PROCEDURE USING A MASS PROVER**

#### **Level Testing**

Place the DUT on a reasonably level surface and conduct the following tests:

- Visually inspect the DUT checking for deviations from approval, hoses plumbed incorrectly causing binding and additional items secured to the device that may affect its accuracy (i.e. Mud flaps and fenders must be secured to the frame of the vehicle, not the scale).
- Test load discrimination using test weights.

<b>Field Inspection Manual</b>	Part: <b>3-STP</b>	Section: <b>27</b>	Page: <b>2 of 3</b>
<b>Non Automatic Weighing Devices</b>	Issued: <b>2004-03-01</b>	Revision Number: <b>Original</b>	

## **STP-27      NH<sub>3</sub> On-Board Weighing Systems - Product Test**

- Prior to zeroing the Mass Prover, equalize the vapour pressure between the two vessels.
- Test blanking at capacity where possible.
- Transfer the first test load (500e minimum) from DUT to the Mass Prover. Difference between indications of the Mass Prover and the DUT must not exceed the applicable LOE. LOE is based on indication obtained from the Mass prover.
- Where DUT is equipped with a ticket printing device, check for agreement between registrations and required information. Check that the printer is inhibited from printing when excessive motion is experienced.

### **Off Level Testing**

- Visually inspect the device when conducting tests outlined below to ensure that any shifting that may have occurred due to inclination does not interfere with the devices' accuracy.
- Elevate the front or rear wheels of the DUT using supplied ramps or a ramp in the traders yard to one half of the maximum approved inclination specified in the NOA. Perform the tests described under "level testing" above, except the section and repeatability test.
- Elevate one rear wheel or tandem so the scale is at or near one half the maximum approved inclination value specified in the NOA. Perform the tests described under "level testing" above, except the section and repeatability test.
- Test blanking when maximum approved angle of inclination is exceeded.
- Test load discrimination with device at the lowest attainable weight.

### **INTERPRETATION OF RESULTS**

The device meets the requirements if :

- a) it provides a weight indication when off level up to at least 3 degrees, in any direction;
- b) it performs within the prescribed limits of error when levelled and when off level by the larger of 3 degrees or the maximum angle at which it still provides a weight indication;
- c) it blanks its indications and prevents the recording of weight values when it ceases to perform within limits of error.

Field Inspection Manual	Part: <b>3-STP</b>	Section: <b>27</b>	Page: <b>3 of 3</b>
Non Automatic Weighing Devices	Issued: <b>2004-03-01</b>	Revision Number: <b>Original</b>	

**STP-27 NH<sub>3</sub> On-Board Weighing Systems - Product Test**

**MINIMUM TEST LOAD REQUIREMENTS**

DUT (Class III)			Mass Prover	
Graduation (e)	LOE IS 500e < m ≤ 2 000e	LOE ACC 500e < m ≤ 2 000e	Graduation (e)	Test Load (Minimum)
0.5 kg	1.0 kg (10x)	0.5 kg (5x)	0.1 kg	>250 kg
1.0 kg	2.0 kg (10x)	1.0 kg (5x)	0.2 kg	>500 kg
2.0 kg	4.0 kg (8x)	2.0 kg (4x) <sup>1</sup>	0.5 kg	>1 000 kg
5.0 kg	10.0 kg (10x)	5.0 kg (5x)	1.0 kg	>2 500 kg

This table may be used as a guideline for Class IIIHD devices as the applicable LOE is larger.

**REVISION**

Original document

---

<sup>1</sup> The Mass Prover selected in this case does not meet the 1/5 of the device LOE. Therefore, to conduct an initial inspection of this device, the test load size must be increased to more than 2 000 e (Class III), or a mass prover with smaller graduations used. Consult your regional gravimetric specialist for more information.

Field Inspection Manual	Part: 3-STP	Section: 28	Page: 1 of 8
Non Automatic Weighing Devices	Issued: 2008-01-01	Revision Number: 1	

## STP-28 MULTI-INTERVAL AND MULTIPLE RANGE DEVICES

### REFERENCE

Sections 3, 5, 6, 8, 9, 16, 31 to 33 of the *Specifications Relating to Non-automatic Weighing Devices (1998)*.

STP-3, STP-11, STP-13.

### PURPOSE

This section provides additional guidelines for the examination and testing of multi-interval and multiple range devices.

**NOTE:** a weight indicator tested separately will have been set and tested for a maximum number of intervals  $n_{max}$  and for a minimum value of verification scale interval  $e_{min}$  across the range.

### 28.1 Multi-interval devices

**Multi-interval device** means a device having one weighing range which is divided into partial weighing ranges each with different scale intervals, with the weighing range determined automatically according to the load applied (pre-determined ranges/intervals), both on increasing and decreasing loads.

The limits of error are determined on the basis of the class of the device and the value of the verification scale interval  $e$  of the partial range corresponding to the load applied.

Intervals and capacities

- 28.1.1 On a multi-interval device, the value of the verification scale interval of a particular range must be lower than the value of the verification scale interval of the next range ( $e_1 < e_2 < e_3$ , etc.)
- 28.1.2 Each partial range of a multi-interval device must have the same value of actual scale interval for both increasing and decreasing loads. The actual scale interval  $d$  must equal the verification scale interval  $e$ .
- 28.1.3 Each partial range of a multi-interval device must have the number of scale intervals  $n$  required by section 3 of the Specifications.

Example: each partial range of a Class III device must have a minimum of  $500n$  and a maximum of  $10\,000n$ . The number of scale intervals  $n$  for each partial range is determined by dividing the scale capacity for the partial range by the verification scale interval  $e$  for that partial range. See the following tables:

Field Inspection Manual	Part: <b>3-STP</b>	Section: <b>28</b>	Page: <b>2 of 8</b>
Non Automatic Weighing Devices	Issued: <b>2008-01-01</b>	Revision Number: <b>1</b>	

**STP-28 MULTI-INTERVAL AND MULTIPLE RANGE DEVICES**

Examples of devices that do not satisfy section 28.1.3

	Partial Range	e	n	Max / e
First	0 - 3 kg	1 g	3 000	3 000 / 1
Second	3 - 6 kg	2 g	3 000	6 000 / 2
Third	6 - 60 kg	5 g	<b>x 12 000</b>	60 000 / 5

	Partial Range	e	n	Max / e
First	0 - 1 kg	1 g	1 000	1 000 / 1
Second	1 - 5 kg	5 g	1 000	5 000 / 5
Third	5 - 8 kg	20 g	<b>x 400</b>	8 000 / 20

Example of a device that does satisfy section 28.1.3

	Partial Range	e	n	Max / e
First	0 - 1 kg	1 g	1 000	1 000 / 1
Second	1 - 5 kg	2 g	2 500	5 000 / 2
Third	5 - 8 kg	5 g	1 600	8 000 / 5

28.1.4 Maximum Capacity of Partial Weighing Ranges (**Recommendation Only** - OIML R76 3.3.3)

With the exception of the last partial weighing range, the requirements below shall be complied with, according to the accuracy class of the device.

Class	I	II	III	IIIHD	IIII
<b>Max<sub>i</sub> / e<sub>i+1</sub></b>	≥ 50 000	≥ 5 000	≥ 500	≥ 500	≥ 50

Tare features

28.1.5 The maximum tare value that may be entered shall not exceed **Max<sub>1</sub>**.

28.1.6 Whenever gross and tare weights fall in different weighing ranges, the net weight must always be in mathematical agreement with the gross and tare weights that are displayed and recorded (simultaneously or in sequence) (**net = gross - tare**).

Field Inspection Manual	Part: <b>3-STP</b>	Section: <b>28</b>	Page: <b>3 of 8</b>
Non Automatic Weighing Devices	Issued: <b>2008-01-01</b>	Revision Number: <b>1</b>	

**STP-28 MULTI-INTERVAL AND MULTIPLE RANGE DEVICES**

28.1.7 The tare value must be equal to the value of the displayed scale division for all methods of tare entry ( $d_{tare} = d$ ). An attempt to enter, in the first range of a multi-interval scale, a tare value that is not equal to  $d$  must be rejected or rounded off to the nearest scale interval.

Example: a multi-interval scale has a 2 g interval in the first range and 5 g in the second range. A keyboard entry of 5 g in the first range must be either rounded to 4 g or 6 g or rejected.

28.1.8 Weight values (Net or Gross) must always begin with the lowest weighing range on the device regardless of the amount of keyboard or platter tare that is taken.

Example: a multi-interval scale has two ranges: The first range 0-2 kg by 2 g, and the second 2-5 kg by 5 g. A platter tare of 1 kg is taken; the device indicates zero. Then, the device must indicate the net weight from 0 up to 2 kg in intervals of 2 g; and from 2 up to 4 kg, in intervals of 5 g.

28.1.9 When Gross, Tare and Net weights are indicated or printed, there shall be mathematical agreement in all circumstances. The tare value must be **rounded off** to permit mathematical agreement.

Example: A multi-interval device has two ranges. The first range 0-2 kg by 2 g, and the second 2-5 kg by 5 g. A keyboard tare of 1.998 kg is entered (in 2 g intervals); a gross load of 2.115 kg (in 5 g intervals) is put on the platter. The net weight indicated must be either 0.116 kg or 0.118 kg (first range; rounded off to 2 g interval). If the gross, net and tare weights are indicated, they must be as follows:

	Gross	Tare	Net
either	2.115 kg	<b>1.999 kg</b>	0.116 kg
or	2.115 kg	<b>1.997 kg</b>	0.118 kg

28.1.10 A tare value entered in the lower range may be either rounded off to the nearest value of the interval of the higher range in which the weighing occurs, or kept unchanged. In the latter case, the net weight could possibly be displayed with an interval smaller than the interval of the range in which the weighing occurs. When a device displays or prints the gross, net and tare values, in all cases the mathematical equation (**tare + net = gross**) must be satisfied.

Example: a multi-interval scale has a 2 g interval from 0 to 2 kg, and 5 g from 2 kg to 10 kg. A tare of 12 g is entered in the first range and the gross weight is 2 500 g (second range). The scale may display either 2 488 g (tare stored as 12 g) or 2 490 g (rounded off to 10 g).

Field Inspection Manual	Part: 3-STP	Section: 28	Page: 4 of 8
Non Automatic Weighing Devices	Issued: 2008-01-01	Revision Number: 1	

**STP-28 MULTI-INTERVAL AND MULTIPLE RANGE DEVICES**

Marking

28.1.11 The capacity **Max** and verification scale interval **e** must be conspicuously marked near the weight display (See STP-3).

Performance

28.1.12 The limits of error are determined on the basis of the class of the device and the value of the verification scale interval **e** of the partial range corresponding to the load applied.

The following example shows how to determine the limits of error applicable to a Class III, 15 kg weighing device with partial ranges and verification scale intervals **e** set as follows:

First range      0.000 - 2.000 kg x 0.001 kg (1 gram)  
 Second range    2.000 - 5.000 kg x 0.002 kg (2 grams)  
 Third range      5.000 - 15.000 kg x 0.005 kg (5 grams)

The acceptance limits of error applicable to Class III weighing devices are:

Load expressed in number of verification scale intervals <b>e</b>	Acceptance limits of error expressed in number of verification scale intervals <b>e</b>
0 - 500	±0.5 <b>e</b>
> 500 - 2 000	±1 <b>e</b>
> 2 000 - 4 000	±1.5 <b>e</b>
> 4 000	±2.5 <b>e</b>

Field Inspection Manual	Part: 3-STP	Section: 28	Page: 5 of 8
Non Automatic Weighing Devices	Issued: 2008-01-01	Revision Number: 1	

**STP-28 MULTI-INTERVAL AND MULTIPLE RANGE DEVICES**

The limits of error applicable to each range are therefore:

	Number of verification scale intervals <b>e</b>	Value in kilograms	Limits of Error (Acceptance)
First Range ( <b>e</b> = 1 g)	0 - 500 <b>e</b> > 500 - 2 000 <b>e</b>	0 - 500 g > 500 g - 2 kg	0.5 g (0.5 <b>e</b> ) 1 g (1 <b>e</b> )
Second Range ( <b>e</b> = 2 g)	0 - 500 <b>e</b> > 500 - 1 000 <b>e</b> > 1000 - 2 000 <b>e</b> > 2000 - 2 500 <b>e</b>	0 - 1 kg > 1 - 2 kg > 2 - 4 kg > 4 - 5 kg	N/A N/A 2 g (1 <b>e</b> ) 3 g (1.5 <b>e</b> )
Third Range ( <b>e</b> = 5 g)	0 - 500 <b>e</b> > 500 - 1 000 <b>e</b> > 1000 - 2 000 <b>e</b> > 2000 - 3 000 <b>e</b> > 3 000 <b>e</b>	0 - 2.5 kg > 2.5 - 5 kg > 5 - 10 kg > 10 - 15 kg > 15 kg	N/A N/A 5 g (1 <b>e</b> ) 7.5 g (1.5 <b>e</b> ) N/A

**Clarification:**

1. For any test performed on a multi-interval scale, the limit of error is a function of the verification scale interval **e** of the range corresponding to the test load used. Critical test points are calculated for each interval and include **Max<sub>e</sub>**.
2. The smallest value of the verification scale interval **e** applies to the tests to determine the maximum value of AZTM, the maximum permissible error for the return to zero test and for the creep-return to zero test, etc. The motion detection requirement must be satisfied for each partial range. The shift test must be performed at one-half of the capacity of each partial weighing range.
3. Devices equipped with keyboard or platter tare must meet the tolerances for net loads for any tare taken up to the maximum tare capacity.

Field Inspection Manual	Part: 3-STP	Section: 28	Page: 6 of 8
Non Automatic Weighing Devices	Issued: 2008-01-01	Revision Number: 1	

## STP-28 MULTI-INTERVAL AND MULTIPLE RANGE DEVICES

### 28.2 Multiple Range Devices

**Multiple range device** means a device having two or more weighing ranges with different capacities **Max** and different scale intervals **e** for the same load receptor, each range extending from zero to its capacity **Max** (two or more devices in one). The selection of the range may be manual or automatic.

For the purposes of determining limits of error, each range is considered a separate device. The limits of error for each range are determined on the basis of the value of the verification scale interval **e** of that range.

Number of intervals and capacity

28.2.1 Each range of a multiple range device must have the number of scale intervals **n** as required by section 3 of the Specifications.

28.2.2 For each range, the actual scale interval **d** must equal the verification scale interval **e**.

Zero setting feature

28.2.3 The zero setting feature in any weighing range must also be effective in the greater weighing ranges, if switching to a greater weighing range is possible while the device is loaded. The deviation from zero must be no more than  $0.25 e$ . This is applicable to manual selection or automatic changing of weighing ranges.

Selection of the weighing range

28.2.4. i **Manual selection** of the weighing ranges is allowed from a smaller to a greater weighing range at any load; and

ii is allowed from a greater to a smaller weighing range when there is no load on the platter, and the indication is zero or at a negative net value. The tare operation must be cancelled and zero must be set to  $\pm 0.25 e$ , both automatically.

28.2.5. i **Automatic selection** of the weighing range is allowed from a smaller to the following greater weighing range when the load exceeds the maximum gross weight of the range being operated; and

ii is allowed from a greater to a smaller weighing range when there is no load on the platter and the indication is zero or at a negative net value; the tare operation must be cancelled and zero must be set to  $\pm 0.25 e$ , both automatically.

Tare features

28.2.6 The tare value may only be transferred from one weighing range to another one with a larger verification scale interval **e**.

Field Inspection Manual	Part: 3-STP	Section: 28	Page: 7 of 8
Non Automatic Weighing Devices	Issued: 2008-01-01	Revision Number: 1	

**STP-28 MULTI-INTERVAL AND MULTIPLE RANGE DEVICES**

28.2.7 The tare operation shall be effective also in the greater weighing range, if switching to a greater weighing range is possible when the device is loaded.

28.2.8 The tare value must be equal to the value of the displayed scale division for all methods of tare entry ( $d_{tare} = d$ ). An attempt to enter, in the lower range of a multiple range scale, a tare value that is not equal to  $d$  must be rejected or rounded off to the nearest actual scale interval  $d$ .

*Example: a scale has a 2 g interval in the first range and 5 g in the second range. A keyboard entry of 5 g in the first range must be either rounded to 4 or 6 g or rejected.*

28.2.9 A tare value entered in the lower range **must be rounded off** to the nearest actual scale interval  $d$  of the higher range in which the NET weighing occurs.

*Example: an automatic multiple range scale has a 2 g interval from 0 to 2 kg (lower range), and 5 g from 0 to 10 kg (higher range). A tare of 13 g is entered in the lower range and the gross weight is 2 500 g (second range). The tare value must be rounded to 15 g and the scale must display 2 485 g (rounded off to 15 g).*

28.2.10 In all cases, the net weight must be in mathematical agreement with the gross and tare weights that are displayed and recorded (**net = gross - tare**).

Indication of the range in use

28.2.11 The range in which the device operates shall automatically and clearly be indicated for both the operator and the consumers.

**Clarification:**

If a scale has a decimal point and a different number of decimal places in each weighing range, the position of the decimal point and the number of digits following is an adequate definition of the weighing range in use. If the weighing range does not utilize a decimal point and differing numbers of decimal places (e.g. scale division are 20, 50 and 100 lb), another method must be provided to indicate the weighing range in use. A display of the capacity by division with an annunciator located near the weight display such as the following is acceptable:

Range in use		
Range 1	5 x 0.002 kg	⊛
Range 2	20 x 0.005 kg	○

Field Inspection Manual	Part: <b>3-STP</b>	Section: <b>28</b>	Page: <b>8 of 8</b>
Non Automatic Weighing Devices	Issued: <b>2008-01-01</b>	Revision Number: <b>1</b>	

**STP-28            MULTI-INTERVAL AND MULTIPLE RANGE DEVICES**

**Marking**

28.2.12            Each weighing capacity by division must be clearly indicated near the weight display. If the manufacturer chooses to indicate which weighing range is in operation using the method recommended above (with annunciator), no other marking of capacity by division is required.

**Performance**

28.2.13            Each range is considered a separate device. The limits of error for each range are determined on the basis of the value of the verification scale interval of that range.

**Clarification:**

1.            Each weighing range of a **multiple range scale** is considered to be an individual scale and must be evaluated accordingly.
2.            After returning to zero from any load greater than **Max<sub>1</sub>**, and immediately after switching to the lowest weighing range (manually or automatically), the indication near zero must not vary by more than **e<sub>1</sub>**, during the following 5 minutes.

**REVISION**

Rev 1.

- added section 28.1.4, Maximum Capacity of Partial Weighing Ranges (OIML R76 3.3.3) Recommendation Only
- corrected **d** must equal **e** references.
- added table data for calculating **n** in section 28.1.3
- corrected general formatting issues.
- correct references to *Specifications Relating to Non-automatic Weighing Devices (1998)*.

Field Inspection Manual	Part: 3-STP	Section: 29	Page: 1 of 3
Non Automatic Weighing Devices	Issued: 2008-01-01	Revision Number: Original	

## STP-29 CALIBRATION OF COUNTERPOISE AND OTHER TRADE WEIGHTS

### REFERENCE

Sections 71- 90 of the *Weights and Measures Regulations*, Divisions II - Weights.

### GENERAL

Many weighing devices, both Automatic and Non-Automatic, use weights as part of their operation. These weights may either be counterpoise weights, designed to increase the capacity of the device, or they may be trade weights used to compare the load being weighed to a known load. These weights are not considered standards, but rather Trade Weights.

The Design, Composition and Construction as well as the Performance (Limits of Error) and Use of these weights must be in accordance with the applicable sections of the W&M Regulations. Trade weights are normally tested at the same time the device is being tested.

### EXAMINATION

Examine the trade or counterpoise weights to ensure that they are in good condition. Ensure:

- the weights are free from rust, cracks or any other significant flaws .
- there is lead in each adjusting hole. (NOTE: Maximum two adjusting holes)
- the lead is stamped with suitable inspection marks.
- the value of the weight is indicated,  
and in the case of counterpoise weights;
- the ratio or weight represented is marked.
- the ratio is suitable for the device the weights are associated with.

**Note:** Where the size of each adjusting hole does not allow for the *inspection marks* to be made in numbers or letters of not less than 3 mm, a smaller *inspection stamp* may be used. In such situations, the *inspection marks* shall be located on the container where the counterpoise or the trade weight is kept when not in use, while the *inspection stamps* are on the weight.

Appropriate *inspection stamps* for ASP inspectors include the organization number or a recognized symbol described in their Quality Documentation and authorized in Appendix 4 of the relevant requirements (Accreditation or Registration program). Measurement Canada inspectors use the symbol of the flag (bar & maple leaf) or of the crown.

If calibration of these weights is required, then it shall be done as per the following procedure.

Field Inspection Manual	Part: 3-STP	Section: 29	Page: 2 of 3
Non Automatic Weighing Devices	Issued: 2008-01-01	Revision Number: Original	

## STP-29 CALIBRATION OF COUNTERPOISE AND OTHER TRADE WEIGHTS

### PROCEDURE

#### Substitution Method - Direct Reading - Automatic Indicating Scale

Using the attached table, choose a balance that has n interval size equal to or smaller than the  $e_{max}$  shown for the corresponding nominal value of the trade weight to be verified or calibrated.

**Note:**  $e_{max}$  is the maximum interval size that a balance can have in order to calibrate trade weights and is calculated so that one scale interval represents at most  $1/3$  of the applicable tolerance for the trade weight to be verified or calibrated.

**Note:** In order to reduce any eccentricity error, always place the local standard and trade weight in approximately the same location on the load receiving element (LRE).

1. Place on the LRE, the local standard of the nominal value of the weight to be calibrated and note the indicated value as Dv1. Repeat this step 5 times. Dv1 must not change by more than  $1 e_{max}$ . If it does then the balance should not be used to verify/calibrate this value of trade weight.
2. Remove the local standard and zero the device. Place the local standard back on the LRE along with a standard equivalent to the 'Over Marked Weight' Acceptance or In-Service Limit of Error (i.e. at the same time) and note the indicated value as Dv2. The scale indication must have changed by at least 3 scale intervals. If not, the load discrimination ability of the scale is not adequate for calibration of the trade weight.

**Note:** Dv2 is the target displayed value for 'Over Marked Weight' from the nominal value of that trade weight for both Acceptance and In- Service Limit of Error.
3. Determine the target displayed value equivalent to the Limit of Error for 'Under Marked Weight' from nominal value (Dv3) for the In-Service Limit of Error.  $Dv3 = Dv1 - (Dv2-Dv1)/2$  rounded up to the nearest scale interval (based on  $e_{max}$ ).
4. Place on the LRE the trade weight to be calibrated or verified.  
For Acceptance Limit of Error, the displayed value must fall between Dv1 and Dv2.  
For In-Service Limit of Error, the displayed value must fall between Dv3 and Dv2.
5. If the displayed value is outside the Limit of Error, adjust the trade weight so that it falls between Dv1 and no more than  $1 e_{max}$  'Over Marked Weight' for either Acceptance or In-service LOE.
6. Once 5 trade weights have been calibrated/verified as above, and again when all the weights of the same nominal value have been calibrated or verified, place the Local Standard on the platform to verify that Dv1 had not changed. If it has changed by more than  $1 e_{max}$ , you must re-establish the values of Dv1, Dv2 and Dv3 and recheck the 5 previous weights.
7. Repeat for each nominal value of trade weight to be calibrated/verified.

Field Inspection Manual	Part: 3-STP	Section: 29	Page: 3 of 3
Non Automatic Weighing Devices	Issued: 2008-01-01	Revision Number: Original	

**STP-29 CALIBRATION OF COUNTERPOISE AND OTHER TRADE WEIGHTS**

Values of $e_{max}$ for the Verification of Trade Weights				
METRIC		AVOIRDUPOIS		
Trade Weight Nominal Value	$e_{max}$	Trade Weight Nominal Value		$e_{max}$
gram(s)	milligram(s)	pound(s)	ounce(s)	pound(s)
1	1		$\frac{1}{16}$	0.000 005
2	2		$\frac{1}{8}$	0.000 005
5	2	0.01		0.000 005
10	5		$\frac{1}{4}$	0.000 01
20	5	0.02		0.000 01
50	10		$\frac{1}{2}$	0.000 01
100	10	0.05		0.000 02
200	20		1	0.000 02
500	20	0.1		0.000 02
<b>kilogram(s)</b>	<b>gram(s)</b>		2	0.000 02
1	0.05	0.2		0.000 05
2	0.1		4	0.000 05
5	0.2	0.5	8	0.000 05
10	0.5	1	16	0.000 1
20	1	2		0.000 2
		5		0.000 2
		10		0.000 5
		20		0.001
		50		0.002

**Note:**  $e_{max}$  is calculated so that one scale division represents at most  $\frac{1}{3}$  of the applicable tolerance for the trade weight to be verified or calibrated.

**REVISION**  
Original

Field Inspection Manual	Part: 3-STP	Section: 30	Page: 1 of 10
Non Automatic Weighing Devices	Issued: 2008-10-01	Revision Number: Original	

## STP-30 MECHANICAL SCALES

### REFERENCE

Non-Automatic Weighing Devices Specifications.

### GENERAL

Although mechanical non-automatic weighing devices are covered by all relevant Standard Test Procedures (STP's) in the Non-Automatic Weighing Device (NAWDS), Field Inspection Manual (FIM), certain mechanical weighing devices may require additional specific tests not otherwise covered in the FIM. These tests are outlined in this STP for reference as required.

Mechanical scales may be fitted with electronic or mechanical indicators. Electronic indicators are covered in other STP's and will not be addressed in this procedure. Mechanical indicators may be broadly grouped into two distinct types - self indicating and non-self indicating types. These should not be confused with Automatic and Non-Automatic weighing devices.

### 1.0 Weighbeam (non automatic indicating)

A mechanical lever scale may be fitted with a *weighbeam* to counterbalance the force generated through the lever system. Each weighbeam will be equipped with a *counterpoise* which is moved along the beam to counterbalance the weighbeam and bring it into an equilibrium or balance condition. Weighbeams equipped with more than one beam and poise are referred to as *compound beams*. The balance condition is usually indicated by the alignment of two points, one on the weighbeam, the other on, or near, the *trig loop*. At this point, the corresponding weight may be read from the scale(s) on the weighbeam. In the case of compound weighbeams, the weight indicated on each is read and then summed to find the total weight. The graphic is intended to be representative of a typical weighbeam only. Not all weighbeams will have all features shown.

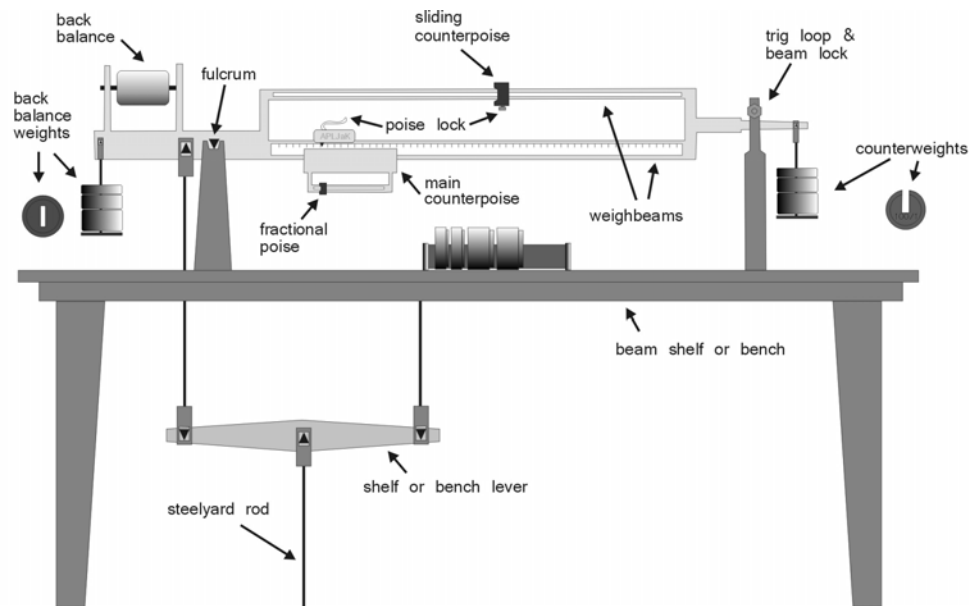

Figure 1 - Compound Weighbeam

<b>Field Inspection Manual</b>	Part: <b>3-STP</b>	Section: <b>30</b>	Page: <b>2 of 10</b>
<b>Non Automatic Weighing Devices</b>	Issued: <b>2008-10-01</b>	Revision Number: <b>Original</b>	

## **STP-30            MECHANICAL SCALES**

### **1.1        Zero Balance / Back Balance**

Scales equipped with weighbeams may be zeroed before use by several different methods. The most common is a back balance zero adjustment. This is a weight located on the end of the beam opposite of the counterpoise(s). This back balance weight is usually operated by a detachable tool (screwdriver, etc.) and is used to set the initial zero balance condition of the beam. It should not be adjusted while weighing is in progress.

Other means of setting initial zero balance include weights located on either end of the beam. Often, the counterweight hanger will include a zero balance weight. In some cases, there is also a hanging weight on the opposite end of the beam. In both cases, these weights must be securely attached or enclosed so that they cannot be changed while weighing is in progress. Removable open slotted ratio weights, commonly used as counterweights, are not acceptable for use as zero balance weight.

#### **Procedure**

Unlock the weighbeam. Adjust the zero balance weights until the weighbeam reaches an equilibrium or balance condition in the center of the trig loop. Relock the weighbeam. Unlock the weighbeam a second time and ensure that the beam again returns to a zero balance condition. Ensure that all material used as zero balance weight is totally enclosed inside a compartment or otherwise not easily removed from the beam. Ensure that the zero back balance adjustment may only be operated by a removable tool and that the zero balance condition may not be readily altered while weighing.

Note, trig loops will sometimes become magnetized causing steel weighbeams to stick. In these cases, the weighbeam may have to be freed by hand. In these cases, the trig loop may need to be demagnetized. This is not a problem with non-ferrous weighbeams.

Always relock the beam before adding or subtracting a significant load from the load receiving element.

### **1.2        Beam Ratios**

Weighbeams and counterpoises must be properly configured for the designed multiplication ratio. When inspecting the scale, the inspector shall verify that the ratio of the scale has been set properly.

#### **Procedure**

Begin by zeroing the scale with no load on the load receiving element. This is done using a combination of back balance weights, adjustable back balance and adding or removing weight from the counterweight hanger.

Using known test standards representative of the scale ratio, place a load on the load receiving element and the corresponding load on the counterweight hanger. For example, a 100:1 platform scale should have 100 kg of standards placed on the load receiving elements and a 1 kg standard set on the counterweight hanger. With all the counterpoises set and locked at zero, the beam should indicate a balanced condition. If it does not, then the main scale ratio is not set correctly. All subsequent testing will be problematic. It is recommended that the standards chosen for this test are equivalent to the standard ratio of one of the poise weights. This will facilitate conducting the subsequent tests.

Field Inspection Manual	Part: <b>3-STP</b>	Section: <b>30</b>	Page: <b>3 of 10</b>
Non Automatic Weighing Devices	Issued: <b>2008-10-01</b>	Revision Number: <b>Original</b>	

## STP-30      MECHANICAL SCALES

### 1.3      Counterpoise

Once the correct beam ratio has been confirmed, the counterpoise(s) may be tested.

Weighbeams will be equipped with at least one and sometimes several counterpoises. Sliding counterpoises must be adjusted appropriately for the weighbeam they are to be used with. Counterpoises are sealed at out the time of manufacture. Any subsequent changes to the counterpoise weight will result in erroneous measurements. Counterpoises may be equipped with some form of locking device. These include lock pawls, lock screws, etc. Parts added to or taken away from the counterpoise may result in erroneous measurement on the scale.

#### Procedure

Visually examine the counterpoise to ensure that it is properly assembled and any fasteners used to assemble it are tight. The counterpoise lock (screw or handle), if equipped, must be of a factory design and must not be removable. If the counterpoise lock screw has been replaced with a generic bolt/screw, the scale will likely not be weighing properly. After the ratio of the device has been confirmed, a load equivalent to the capacity of the lowest capacity beam may be placed on the load receiving element and, with the other counterpoises locked at zero, the appropriate counterpoise moved to this capacity. The beam should again indicate a balanced condition. Return this counterpoise to zero and ensure it is locked. Move each of the other counterpoises to the appropriate capacity indication and ensure that the beam balances. Once this has been done, increase the load on the device to the maximum capacity of the next beam and repeat the test. Continue until all beams have been tested.

Many large capacity beams will have a *fractional poise* incorporated into the main counterpoise. This fractional poise is intended to allow more precise readings within the larger divisions of the main counterpoise. The fractional poise must be tested using known weight on the load receiving element. Always ensure the fractional poise is returned to zero before continuing with testing of the main counterpoise.

Sliding counterpoises may be equipped with a locking screw, a ratchet stop or other means to hold the counterpoise in the desired location. In all cases, ensure that the sliding counterpoise can be securely located at the intended reading on the beam. The locking mechanism should hold the counterpoise firmly. If the beam is equipped with notches to locate the counterpoise, these notches should be in good condition and not overly worn.

### 1.4      Counter Weights or Ratio Weights

Weighbeams will often be equipped with counterweights used to increase the overall capacity of the beam. It is important that the ratio of these weights as well as the actual weight is correct for the device they are to be used with.

#### Procedure

The first thing to check is that the correct counterweights are with the scale. Either the beam ratio or the apparent and actual weights will be marked on the counterweights. If the ratio is not specified, it may be calculated as apparent weight/actual weight. Typical ratios are 100:1, 40:1, etc. Counterweights which are not designed for use with the scale (i.e. wrong ratio) should be removed from the device. Scales commonly referred to as "union scales" will have counterweights with two apparent weights. The two ratios reflect the apparent weight for either the scale pan or the platform.

Field Inspection Manual	Part: <b>3-STP</b>	Section: <b>30</b>	Page: <b>4 of 10</b>
Non Automatic Weighing Devices	Issued: <b>2008-10-01</b>	Revision Number: <b>Original</b>	

## STP-30      MECHANICAL SCALES

Counterweights are usually adjustable and will contain one or more adjusting holes, each of which must contain adjusting lead. They may also contain one or more weight reducing holes. The adjustment should be made using a suitable scale or balance (see STP-29).

Using known test standards representative of the scale ratio, place a load on the load receiving element and the corresponding load on the counterweight hanger. For example, a 100:1 platform scale should have 100 kg of standards placed on the load receiving elements and a 1 kg standard set on the hanger. With the counterpoise(s) set and locked at zero, the beam should indicate a balanced condition. If it does not, then the main beam ratio is not set correctly (see above). Next, remove the 1 kg standard from the counterweight hanger and replace it with the 100:1 counterweight. The beam should again come into a balanced condition. In no case should the counterweight be adjusted to compensate for an incorrectly set beam ratio. Counterweights should not be adjusted on the scale being tested (see STP-29).

Repeat the test with each of the other counterweights. Note that it may not be possible to apply a sufficient amount of known standards to the weight hanger for the larger counterweights. Since the ratio of the device has already been established, this step is not necessary for all counterweights.

Note: The beam should always be locked when loading or unloading the scale.

### 1.5      Type Register Printer

Many larger weighbeams were equipped with *type register printers*. If still in use, these printers should be checked during an inspection. The printer should be checked for accuracy at several locations along the length of the beam.

#### Procedure

Locate the counterpoise at the desired position on the beam. Place a ticket into the printer and firmly squeeze the print handle. Release the handle and remove the ticket. The value printed on the ticket should correspond to the location of the poise on the beam. The scale need not be loaded for this test.

Field Inspection Manual	Part: 3-STP	Section: 30	Page: 5 of 10
Non Automatic Weighing Devices	Issued: 2008-10-01	Revision Number: Original	

## STP-30 MECHANICAL SCALES

### 2.0 DIAL , DRUM & FAN (self-indicating)

A mechanical lever scale may be fitted with a *dial (drum or fan)* to counterbalance the force generated through the lever system. The dial may be equipped with a tare beam, a capacity beam and/or drop weights (unit weights). The dial is considered to be self indicating as no operator intervention is required to read the weight indication. However, if the capacity beam or drop weights are used, these weights must be added to the dial indication to read the total weight. If a tare beam is used, the total will be Net weight as the tare weight of the container will have been balanced off using the tare beam before a weight is read. Tare beams are not intended to re-zero an unloaded scale. The graphic is intended to be representative of a typical dial indicator only. Not all dials will have all features shown.

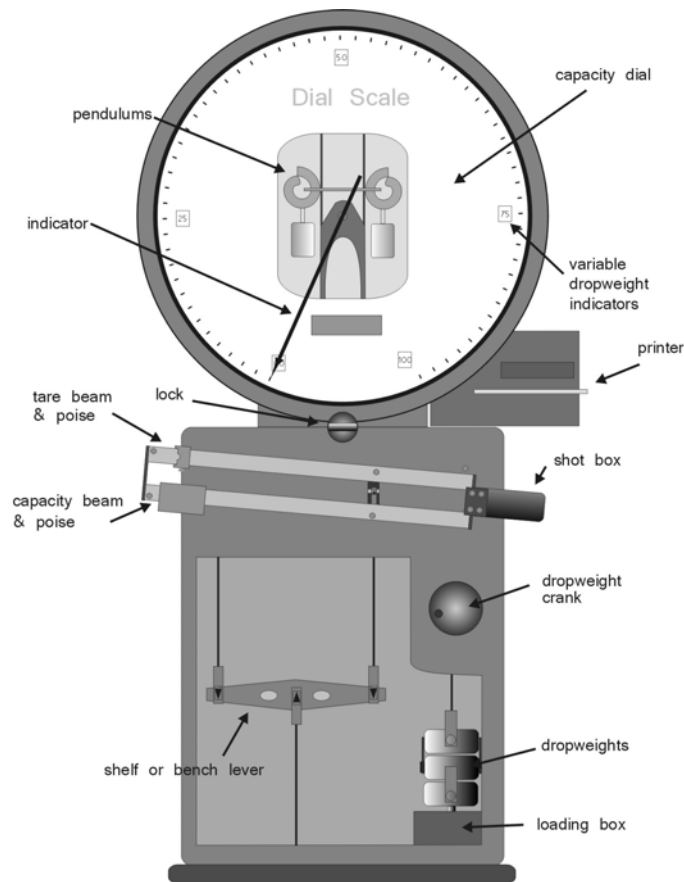

**Figure 2** - Cabinet Dial

#### 2.1 Zero Balance

There are several methods for zeroing a self-indicating scale. Coarse zero on a dial is set using the shot box and the loading box. Operator zero is usually in the form of a screw accessible through the dial cabinet. It will typically be covered with a small cover plate which swings aside to allow access. Turning the screw will re-zero the scale.

<b>Field Inspection Manual</b>	Part: <b>3-STP</b>	Section: <b>30</b>	Page: <b>6 of 10</b>
<b>Non Automatic Weighing Devices</b>	Issued: <b>2008-10-01</b>	Revision Number: <b>Original</b>	

## **STP-30            MECHANICAL SCALES**

Coarse zero on a fan scale is accomplished by adjusting the load in the shot box, typically located under the scale platter. Fine zero on some devices may be available through an external user zero screw, often through the scale cabinet.

### 2.2     Dial Capacity

The dial capacity should be tested using test standards on hand. The dial must be tested from 0 to dial capacity. Whenever loading or unloading a large capacity dial scale, the dial lock should be engaged to prevent damage to the mechanism. Special attention should be paid to testing the dial at the “quarters”.

### 2.3     Testing Quarters

Pendulum counterbalanced dial scales are designed so that, in addition to the overall ratio of the scale understructure, the dial itself may be adjusted at each of the four quarters or quadrants. These adjustments are relatively independent of one another.

#### Procedure

In addition to all other tests, weights approximately equivalent to 25%, 50%, 75% and 100% of the dial capacity shall be used to check the quarter adjustments of a dial scale.

### 2.4     Tare & Capacity Beams

Tare beams (usually unmarked) and capacity beams (marked) are weighbeams equipped with sliding poises commonly found on self indicating dial scales. Tare beams are provided for taring off loads before a Net weight is determined on the scale. Capacity beams are provided to periodically increase the weighing capacity of the dial scale. Both beams have an affect on the overall capacity of the device and therefore must be tested.

#### Procedure

Tare beams without markings are used to zero off (tare) a containers weight. The container is placed on the scale and the tare beam counterpoise is moved along the beam until the dial indicates zero. The counterpoise is then locked at this point. As the beam is generally unmarked, the tare weight is unknown.

Capacity beams will be marked with additional scale capacity, although usually only a few very large divisions (equivalent to the dial capacity or a fraction thereof). These should be tested as per a weighbeam scale. That is, a load equivalent to the maximum capacity of the tare beam shall be applied to the load receiving element and the poise moved to indicate the same load. The dial shall indicate zero load. This test may be conducted at anytime while testing the device. In all cases, the indicated weight on the dial shall be equal to the actual load on the load receiving element, minus the value indicated by the tare beam.

As both beams increase the effective overall capacity of the scale, the scale must be tested with both beams in use. Sufficient capacity is to be added to the load receiving element so that both the Tare and Capacity beams (if so equipped) are in full use. The remaining dial capacity is then tested. The additional load compensated for by the tare and capacity beams should be left on the device during this testing.

<b>Field Inspection Manual</b>	Part: <b>3-STP</b>	Section: <b>30</b>	Page: <b>7 of 10</b>
<b>Non Automatic Weighing Devices</b>	Issued: <b>2008-10-01</b>	Revision Number: <b>Original</b>	

## **STP-30            MECHANICAL SCALES**

### **2.5       Drop Weights**

Large capacity dial scales may be equipped with drop weights (sometimes referred to as unit weights) to increase the overall capacity of the scale. Each of these drop weights must be properly calibrated to ensure that the second and subsequent ranges are set appropriately for the device. Drop weights will be added to the loading box, one at a time to increase the capacity of the dial. Drop weights are usually configured to be equal to the total range of the dial. That is, adding one drop weight will increase the weighing capacity of the device by an amount equal to the dial capacity. In most cases, the weight indications on the dial will increment to correspond to the number of drop weights added.

#### **Procedure**

Starting in the first range (no drop weights), load the device to 100% of the dial capacity. Note any error. Leaving the load on the scale, engage the first set of drop weights. The variable drop weight capacity indicators, if equipped, should change to reflect the new capacity of the device. The dial pointer should return to the start of the dial. Test the entire range of the dial again. Repeat for each set of drop weights.

Dials and lever ratios should not be adjusted while drop weights are in use. Doing so will introduce an error into the first range (no drop weights) of the device.

### **2.6       Printers**

Although not common, some dial scales were equipped with mechanical printers. If still in use, these must be tested during inspection of the device.

#### **Procedure**

A weight ticket is to be inserted into the printer and a print initiated. The printed ticket must show the same weight as is displayed on the dial. This test must be repeated several times during the inspection with particular attention paid to printing when drop weights have been introduced. These printers will not usually include units or other information. All other required information must be preprinted on the weight tickets.

### **2.7       One Spot Indicators**

Some dial scales are unique in that instead of a weight indication being given through the use of a moveable pointer, the entire weight chart turns in relation to the load applied. These devices will have the chart completely covered except for a small weight indication window. The weight is read off of the chart through this window. Typically, several weight divisions will be visible, with the actual weight indicated by a hairline indicator or a pointer. Previous tests apply as appropriate.

### **2.8       Fan Scales**

Fan scales are similar to dial scales except that the pointer moves through an arc indicating from zero to full capacity. These indicators are usually seen on lower capacity devices. Fan Scales may be simply weight indicating or the fan may include computing charts. Some scales typically referred to as "check weighers" may include a fan that merely indicates over or under the target weight. In this case, the fan is not graduated with actual weight values. Previous tests apply as appropriate.

<b>Field Inspection Manual</b>	Part: <b>3-STP</b>	Section: <b>30</b>	Page: <b>8 of 10</b>
<b>Non Automatic Weighing Devices</b>	Issued: <b>2008-10-01</b>	Revision Number: <b>Original</b>	

## **STP-30            MECHANICAL SCALES**

### Additional Procedures

Conduct a visual examination to see if the pointer is bent near the fulcrum or pivot point. The pointer will appear to be skewed to the chart if it is bent. This is most noticeable on fan scales with hairline indicators and computing charts. Check that the scale returns to zero indication. Scales with bent pointers have been found readjusted to indicate zero rather than repairing or replacing the bent pointer. These scales will often not have enough range to indicate full scale capacity. This can be tested by placing full scale capacity on the load receiving element and ensuring that the scale indicates correctly.

Ensure that the hairline indicator is intact. Load the device and check the computing charts if equipped.

### 2.9      Drum Scales

Drum Scales use a preprinted horizontally mounted drum to display weights. Often, these drums are also printed with price computing information. The weight is displayed through a window and the price computations are read across the drum, usually with the assistance of a hairline indicator. Previous tests apply as appropriate.

### Additional Procedures

Check that the drum revolves through its entire range smoothly and without binding. Look for dents in the drum which will result in erroneous readings. Ensure that the hairline indicator is intact and mounted horizontally across the drum.

## **3.0      MISCELLANEOUS**

### 3.1      Multiple indicating methods

Many mechanical scales use a combination of indicators. This may include beams in conjunction with dials or fans. Counterweights and trade weights may also be encountered. All means of indication should be tested both independently and again in conjunction with each other to ensure accuracy.

Many self-indicating devices will have two side displays. If so equipped, the inspector must ensure that both indications are in agreement. Unlike an electronic indicating element, mechanical indicating elements are often not in agreement with each other.

Weighbeams must be visually examined to ensure that the markings are correct and legible. Weighbeams must be straight and true.

### 3.2      Electro-Mechanical indicating

Although no longer common, some mechanical scales were equipped with both a mechanical indicator and an electronic indicator. In these cases, the operation of the latter must be inhibited during use of the former. This is often accomplished through the use of a micro-switch on the trig loop of a weighbeam.

Field Inspection Manual	Part: <b>3-STP</b>	Section: <b>30</b>	Page: <b>9 of 10</b>
Non Automatic Weighing Devices	Issued: <b>2008-10-01</b>	Revision Number: <b>Original</b>	

## STP-30      MECHANICAL SCALES

### 3.3      Dampening (Dash-pots)

Most dial and fan scales and some weighbeam scales incorporate a method for dampening the movement of the indicator. In many cases, this is a liquid (commonly oil) filled *dashpot*. Do not tilt or invert a device containing an oil filled dashpot or the oil will be spilled. Empty or dry dashpots will result in an oscillating indication which takes a long time to settle out at a reading. Sticky dashpots sometimes occur when the oil has hardened in the dashpot. This will result in an indicator which does not move freely and will almost certainly result in erroneous readings. There are also other dampening devices in use including magnetic dampeners. In all cases, the dampening device must be checked to ensure it is functioning correctly and is not causing the scale to bind which could result in an incorrect indication.

### 3.4      Pivots and Bearings

Scales which utilize pivots and bearings are often found with broken or missing parts. These should be visibly checked during the inspection to ensure that they are intact and appropriate for the device in question. Scales commonly known as *Union Scales* will often be found missing the bearing loops from the lower weighing element. Replacements for these bearing loops can be hard to find and there will often be homemade replacements installed. These bearings must be properly sized and hardened to ensure the device works properly. Improperly made bearings are not suitable and will often fail on an eccentricity testing. Pivot and bearing failure can be catastrophic and care must be taken to ensure that the load will remain stable should a part fail during testing.

Pivots will often be equipped with anti-friction plates to prevent lateral motion of the pivot on the bearing. These plates must be present and in good shape.

In an effort to incorporate a self checking pivot system, some manufacturers have used ball bearing style pivots. These bearings are captured in hardened cups. The arrangement allows for a controlled amount of lateral motion with an automatic return to a central or neutral position. The inspector must ensure that each of these balls is still present and in good condition.

Check links must be present and not causing binding of the load receiving element. Check links which are not free need adjustment. They must not simply be removed.

### 3.5      Counterpoise or ratio weights

Counterpoise (ratio) weights of the wrong ratio for the device are a common problem. When checking the ratio weights for general condition and to ensure that all adjusting lead is still intact, also note the ratio and ensure that it is appropriate for the device being tested. Ratio weights of the incorrect ratio for the device will cause significant measurement errors. These should be noted on the inspection certificate and removed from the device.

### 3.6      Beam and dial locks

Always lock a beam or dial scale when adding or subtracting a significant load from the load receiving element. Failure to do so can cause damage to the device. Unlock the beam or dial slowly and only after ensuring that the settings are correct for the load to be weighed. This will ensure that the indicator does not slam into a stop with undue force.

<b>Field Inspection Manual</b>	Part: <b>3-STP</b>	Section: <b>30</b>	Page: <b>10 of 10</b>
<b>Non Automatic Weighing Devices</b>	Issued: <b>2008-10-01</b>	Revision Number: <b>Original</b>	

## **STP-30            MECHANICAL SCALES**

### **3.7      Levers**

Lever scales utilize a system of levers mounted on pivots and bearings. There are several different lever trains in common use. In each case, a visible inspection must be made to ensure that all levers are in relative alignment with one another and that there is no possibility of binding while in use. Unlike fully electronic scales, there is an appreciable amount of relative movement of parts in a lever scale.

### **3.8      Mounting and installation**

Weighbeams and dials used on high capacity scales must be securely mounted to a rigid base. They are often affixed to the floor of a scale house. Any relative movement of the scale house floor, in the area of the indicating element mounting, will result in incorrect or non-repeatable indications from the indicating element during use.

### **3.9      Scale decks (load receiving elements)**

Wooden decked scales must be inspected carefully before testing begins. Wooden decks may have deteriorated to the point that they can no longer safely support a test load. This deterioration is not always immediately obvious. Vehicle scales with wooden decks will usually be equipped with longitudinal planking designed to support the tires of the vehicle. This planking is supported by the main frame members of the load receiving element and is therefore where the scale should be loaded. In no case should a vehicle be driven off of these planks onto the transversely mounted timbers.



## **REVISION**

Original



Field Inspection Manual	Part: <b>4-Appendix</b>	Section: <b>A</b>	Page: <b>1 of 3</b>
Non Automatic Weighing Devices	Issued: <b>2008-01-01</b>	Revision Number: <b>1</b>	

## Appendix A

The following table lists acceptable defining words and symbols for the marking of devices. This list does not standardize the abbreviation or symbols that must be used, rather it identifies abbreviations or symbols routinely used. Other abbreviations or symbols, such as those internationally recognized (OIML), are also acceptable.

<b>Abbreviations and Symbols Accepted in Canada</b>			
<b>Units</b>	<b>Definition</b>	<b>Acceptable Symbol</b>	<b>Not Acceptable</b>
kilogram	basic unit	kg	KG, kilo
gram	0.001 kg	g	gr, gm, G, GM
pound	0.453 592 37 kg	lb	LB, lbs, #
ounce	$\frac{1}{16}$ pound (or 437 $\frac{1}{2}$ grains)	oz	OZ
dram	$\frac{1}{16}$ ounce	dr	DR
grain	$\frac{1}{7\,000}$ pound	gr	GRN, grn, GN, g
tonne (or metric ton)	1 000 kg	t	T, TN, tn
ton	2 000 pounds	tn	t, TN, T
cental (or hundredweight)	100 pounds	ctl or cwt	
troy ounce	480 grains	tr oz	
carat	200 milligrams	ct	c
	Zero key or center of zero indicator		
	Tare entered		

### Appendix A

Abbreviations and Symbols Accepted in Canada			
Units	Definition	Acceptable Symbol	Not Acceptable
	Accuracy class	Class I, II, III, III HD, IIII, or symbols enclosed in an ellipse such as:  	I, II, III, III HD, IV or 1, 2, 3, 3 HD, 4
	Maximum number of scale intervals	$n_{max}$	
	Minimum verification scale interval	$e_{min}$	
	Value of the actual scale interval	d	
	Value of the verification scale interval	e	
	Number of scale intervals	n	
	Gross weight	gross, G, GR	
	Tare	tare, T, TA	
	Net weight	net, N, NT	
	Manual weight entry	manual weight MAN WT, MANUAL WT, MAN WEIGHT	M, MW, MAN

Field Inspection Manual	Part: 4-Appendix	Section: A	Page: 3 of 3
Non Automatic Weighing Devices	Issued: 2008-01-01	Revision Number: 1	

## Appendix A

### Additional Authorized Symbols

Units	Symbols	Units	Symbols
Acre	no symbol allowed	Inch (pouce)	in (po)
Bushel (boisseau)	bu	Link (chaînon)	li (chon)
Chain (chaîne)	ch	Mile (mille)	mi
Dram (drachme)	dr	Peck (quart de boisseau)	pk
Fluid dram (drachme fluide)	fl dr	Pint (chopine)	pt (chop)
Fluid ounce (once fluide)	fl oz	Quart (pinte)	qt (pte)
Foot (Pied)	ft (pi)	Rod, perch, pole (perche)	no symbol allowed
Furlong	no symbol allowed	Yard (verge)	yd (vg)
Imperial gallon	gal		
Gill (roquille)	gi		

### REVISION

Rev 1.

Reformat the definition of the gram  
Remove unit "Ton (tonne)" from *Additional Authorized Symbols*

Field Inspection Manual	Part: 4- Appendix	Section: B	Page: 1 of 2
Non Automatic Weighing Devices	Issued: 2004-03-01	Revision Number: Original	

## Appendix B

### CLASS III HD IN-SERVICE LIMITS OF ERROR

In-service LOE in terms of the number of verification scale intervals	Verification scale interval			
	2 kg	5 kg	10 kg	20 kg
	Load in kg	Load in kg	Load in kg	Load in kg
1	0 - 1 000	0 - 2 500	0 - 5 000	0 - 10 000
2	> 1 000 - 2 600	> 2 500 - 6 500	> 5 000 - 13 000	> 10 000 - 26 000
3	> 2 600 - 4 200	> 6 500 - 10 500	>13 000 - 21 000	> 26 000 - 42 000
4	> 4 200 - 5 800	> 10 500 - 14 500	> 21 000 - 29 000	> 42 000 - 58 000
5	> 5 800 - 7 400	> 14 500 - 18 500	> 29 000 - 37 000	> 58 000 - 74 000
6	> 7 400 - 9 000	> 18 500 - 22 500	> 37 000 - 45 000	> 74 000 - 90 000
7	> 9 000 - 10 600	> 22 500 - 26 500	> 45 000 - 53 000	> 90 000 - 106 000
8	> 10 600 - 12 200	> 26 500 - 30 500	> 53 000 - 61 000	> 106 000 - 122 000
9	> 12 200 - 13 800	> 30 500 - 34 500	> 61 000 - 69 000	> 122 000 - 138 000
10	> 13 800 - 15 400	> 34 500 - 38 500	> 69 000 - 77 000	> 138 000 - 154 000
11	> 15 400 - 17 000	> 38 500 - 42 500	> 77 000 - 85 000	> 154 000 - 170 000
12	> 17 000 - 18 600	> 42 500 - 46 500	> 85 000 - 93 000	> 170 000 - 186 000
13	> 18 600 - 20 200	> 46 500 - 50 500	> 93 000 - 101 000	> 186 000 - 202 000
14	> 20 200 - 21 800	> 50 500 - 54 500	> 101 000 - 109 000	> 202 000 - 218 000
15	> 21 800 - 23 400	> 54 500 - 58 500	> 109 000 - 117 000	> 218 000 - 234 000
16	> 23 400 - 25 000	> 58 500 - 62 500	> 117 000 - 125 000	> 234 000 - 250 000
17	> 25 000 - 26 600	> 62 500 - 66 500	> 125 000 - 133 000	> 350 000 - 266 000
18	> 26 600 - 28 200	> 66 500 - 70 500	> 133 000 - 141 000	> 266 000 - 282 000
19	> 28 200 - 29 800	> 70 500 - 74 500	> 141 000 - 149 000	> 282 000 - 298 000
20	> 29 800 - 31 400	> 74 500 - 78 500	> 149 000 - 157 000	> 298 000 - 314 000
21	> 31 400 - 33 000	> 78 500 - 82 500	> 157 000 - 165 000	> 314 000 - 330 000
22	> 33 000	> 82 500	> 165 000	> 330 000

<b>Field Inspection Manual</b>	<b>Part: 4- Appendix</b>	<b>Section: B</b>	<b>Page: 2 of 2</b>
<b>Non Automatic Weighing Devices</b>	<b>Issued: 2004-03-01</b>	<b>Revision Number: Original</b>	

## Appendix B

**THE FOLLOWING FORMULA MAY BE USED TO CALCULATE THE IN-SERVICE LIMITS OF ERROR (LOE) FOR CLASS III HD DEVICES:**

In-service limit of error expressed in terms of "e"

$$LOE = \left[ \frac{(L/e) - 500}{800} \right] + 1$$

(Round the value up to the next whole number)

where:

L = the load or standards used to determine the LOE

e = the value of the verification scale interval

The result is divided by 2 to find the acceptance LOE.

### **Example:**

In-service LOE for a known test load of 11 500 kg

e = 5 kg

$$11\,500 \text{ kg} \div 5 \text{ kg} = 2\,300$$

$$2\,300 - 500 = 1\,800$$

$$1\,800 \div 800 = 2.25$$

$$2.25 + 1 = 3.25$$

$$3.25 \text{ rounded up to the next whole number} = 4 \text{ e}$$

Hence, the in-service LOE is 20 kg (4 x 5 kg) and the acceptance LOE is 10 kg.

### **REVISION**

Original document

Field Inspection Manual	Part: 4 - Appendix	Section: C	Page: 1 of 4
Non-Automatic Weighing Devices		Issued: 2010-04-01	Revision Number: 1

## Appendix C

### Standards Accuracy Class - Non Automatic Weighing Device

The following tables list the required accuracy standard for an inspection of a given device Non Automatic Device class. Individual tables are provided for **Acceptance** and **In-Service** as well as for **Metric** and **Avoirdupois** units of measure.

Metric Device type		Required accuracy class of the standard - Acceptance								
		E <sub>1</sub>	E <sub>2</sub>	F <sub>1</sub>	F <sub>2</sub>	M <sub>1</sub>	M <sub>1-2</sub>	M <sub>2</sub>	M <sub>2-3</sub>	M <sub>3</sub>
N A W D	I (when e ≥ 1 mg)	All	n ≤ 312 500	---	---	---	---	---	---	---
	II (when e ≥ 1 mg)	All	All	All	All <sup>1</sup>	---	---	---	---	---
	III (e ≥ 0.1 g)	All	All	All	All	All	n ≤ 8 333 and e ≥ 20 g	n ≤ 1 667	---	---
	III HD (e ≥ 2 kg)	All	All	All	All	All	n ≤ 36 666	n ≤ 18 333	---	---
	IIII (e ≥ 5 g)	All	All	All	All	All	e ≥ 200 g	All	e ≥ 500 g	All

#### NOTES:

- Class F<sub>2</sub> is equal to Measurement Canada's **Precious Metal Weight Kits**.
- Class M<sub>1</sub> is equal to Measurement Canada's **Inspector's Weight Kits**.
- n is the maximum number of scale intervals which can be verified on the indicated device type, with the indicated accuracy class standard.

<sup>1</sup>This section is under review. Until further notice, Precious Metal Weights (OIML F<sub>2</sub>) are suitable for inspection of all Class II devices.

Field Inspection Manual	Part: 4 - Appendix	Section: C	Page: 2 of 4
Non-Automatic Weighing Devices		Issued: 2010-04-01	Revision Number: 1

### Appendix C

Metric Device type		Required accuracy class of the standard - In Service								
		E <sub>1</sub>	E <sub>2</sub>	F <sub>1</sub>	F <sub>2</sub>	M <sub>1</sub>	M <sub>1,2</sub>	M <sub>2</sub>	M <sub>2,3</sub>	M <sub>3</sub>
<b>N A W D</b>	<b>I (when e ≥ 1 mg)</b>	All	n ≤ 625 000	n ≤ 133 000	---	---	---	---	---	---
	<b>II (when e ≥ 1 mg)</b>	All	All	All	All <sup>2</sup>	n ≤ 13 333 and e ≥ 10 mg	---	---	---	---
	<b>III (e ≥ 0.1 g)</b>	All	All	All	All	All	e ≥ 20 g	n ≤ 8 333	n ≤ 1 667 and e ≥ 50 g	n ≤ 1 333
	<b>III HD (e ≥ 2 kg)</b>	All	All	All	All	All	All	n ≤ 36 667	n ≤ 18 333	n ≤ 2 000
	<b>IIII (e ≥ 5 g)</b>	All	All	All	All	All	e ≥ 200 g	All	e ≥ 500 g	All

**NOTES:**

- Class F<sub>2</sub> is equal to Measurement Canada's *Precious Metal Weight Kits*.
- Class M<sub>1</sub> is equal to Measurement Canada's *Inspector's Weight Kits*.
- n is the maximum number of scale intervals which can be verified on the indicated device type, with the indicated accuracy class standard.

---

<sup>2</sup>This section is under review. Until further notice, Precious Metal Weights (OIML F<sub>2</sub>) are suitable for inspection of all Class II devices.

Field Inspection Manual	Part: 4 - Appendix	Section: C	Page: 3 of 4
Non-Automatic Weighing Devices		Issued: 2010-04-01	Revision Number: 1

### Appendix C

Avoirdupois Device type		Required accuracy class of the standard - Acceptance								
		E <sub>1</sub>	E <sub>2</sub>	F <sub>1</sub>	F <sub>2</sub>	M <sub>1</sub>	M <sub>1,2</sub>	M <sub>2</sub>	M <sub>2,3</sub>	M <sub>3</sub>
N A W D	I	NA	n ≤ 312 500	---	---	---	---	---	---	---
	II		All	All	All <sup>3</sup>	—	—	—	—	—
	III (e ≥ 0.0002 lb or 0.005 oz)		All	All	All	All	n ≤ 8 333 and e ≥ 0.05 lb	n ≤ 1 667	—	—
	III HD (e ≥ 5 lb)		All	All	All	All	n ≤ 36 666	n ≤ 18 333	---	---
	IIII (e ≥ 0.01 lb or 0.2 oz)		All	All	All	All	e ≥ 0.5 lb	All	e ≥ 1 lb	All

#### NOTES:

- Class F<sub>2</sub> is equal to Measurement Canada's *Precious Metal Weight Kits*.
- Class M<sub>1</sub> is equal to Measurement Canada's *Inspector's Weight Kits*.
- n is the maximum number of scale intervals which can be verified on the indicated device type, with the indicated accuracy class standard.

<sup>3</sup>This section is under review. Until further notice, Precious Metal Weights (OIML F<sub>2</sub>) are suitable for inspection of all Class II devices.

Field Inspection Manual	Part: 4 - Appendix	Section: C	Page: 4 of 4
Non-Automatic Weighing Devices		Issued: 2010-04-01	Revision Number: 1

### Appendix C

Avoirdupois Device type		Required accuracy class of the standard - In Service								
		E <sub>1</sub>	E <sub>2</sub>	F <sub>1</sub>	F <sub>2</sub>	M <sub>1</sub>	M <sub>1,2</sub>	M <sub>2</sub>	M <sub>2,3</sub>	M <sub>3</sub>
N A W D	I	NA	$n \leq 625\ 000$	$n \leq 133\ 000$	---	---	---	---	---	---
	II		All	All	All <sup>4</sup>	$n \leq 13\ 333$ and $e \geq 0.2\ \text{gr} \geq 0.0005\ \text{oz tr}$	---	---	---	---
	III ( $e \geq 0.0002\ \text{lb}$ or $0.005\ \text{oz}$ )		All	All	All	All	$e \geq 0.05\ \text{lb}$	$n \leq 8\ 333$	$n \leq 1\ 667$ and $e \geq 0.1\ \text{lb}$	$n \leq 1\ 333$
	III HD ( $e \geq 5\ \text{lb}$ )		All	All	All	All	All	$n \leq 36\ 667$	$n \leq 18\ 333$	$n \leq 2\ 000$
	IIII ( $e \geq 0.01\ \text{lb}$ or $0.2\ \text{oz}$ )		All	All	All	All	$e \geq 0.5\ \text{lb}$	All	$e \geq 1\ \text{lb}$	All

**NOTES:**

- Class F<sub>2</sub> is equal to Measurement Canada's *Precious Metal Weight Kits*.
- Class M<sub>1</sub> is equal to Measurement Canada's *Inspector's Weight Kits*.
- n is the maximum number of scale intervals which can be verified on the indicated device type, with the indicated accuracy class standard.

**REVISION:**

Rev.1 Suspend restriction on Class II devices inspected with Precious Metal Weight Kits (OIML Class F<sub>2</sub> weights)

---

<sup>4</sup>This section is under review. Until further notice, Precious Metal Weights (OIML F<sub>2</sub>) are suitable for inspection of all Class II devices.