



Industry
Canada

Industrie
Canada

CS-03 Part I
Issue 9, Amendment 4
December 2010

Spectrum Management and Telecommunications

Compliance Specification for Terminal Equipment, Terminal Systems,
Network Protection Devices, Connection Arrangements
and Hearing Aids Compatibility

Part I: Requirements for Terminal Equipment (TE) and Related Access Arrangements Intended for Direct Connection to Analogue Wireline Facilities

Contents

1.0	Introduction.....	1
1.1	Scope.....	1
1.2	Technical Requirements.....	1
1.3	Sequence of Equipment Testing.....	4
1.4	Operating States.....	5
1.5	Testing Configuration.....	5
1.6	Connecting Arrangements.....	9
1.7	Operational Check.....	9
1.8	Ringer Equivalence Numbers.....	9
2.0	Electrical and Mechanical Stresses.....	10
2.1	Mechanical Shock.....	10
2.2	Dielectric Strength.....	11
2.3	Hazardous Voltage Limitations.....	14
2.4	Surge Voltage.....	33
2.5	Power Line Surge.....	41
3.0	Network Protection Requirements.....	43
3.1	General.....	43
3.2	For Future Use.....	43
3.3	Extraneous AC Energy.....	43
3.4	Transmitted Signal Power.....	47
3.5	Billing Protection.....	65
3.6	Transverse Balance.....	76
3.7	On-hook Terminal Resistance and Impedance.....	83
3.8	Idle State Terminal Impedance-return Loss and Transducer Loss (Tie Trunk Interface).....	88
3.9	Automatic Dialling and Automatic Redialling.....	93
3.10	Stuttered Dial Tone Detection.....	95
3.11	Manual Programming of Memory Dialling Numbers.....	97
4.0	Special Test Circuits.....	98
4.1	Loop Simulator for Loop-start and Ground-start Circuits.....	98
4.2	Loop Simulator for Reverse Battery Circuits.....	99
4.3	Loop Simulator for 4-Wire Loop/Ground-start Circuits.....	100
4.4	Loop Simulator for 4-Wire Reverse Battery Circuits.....	101
4.5	Off-premises Loop Simulator.....	102
4.6	Alternative Off-hook Termination.....	103
4.7	E&M Signalling.....	104
4.8	Reference Information.....	106
5.0	TE Installation Wiring.....	107
5.1	Scope.....	107
5.2	General.....	107
5.3	Safety Requirements.....	107
5.4	Technical Requirements.....	107
5.5	Qualifications of Installation Supervision.....	108

1.0 Introduction

1.1 Scope

This part sets forth the minimum technical requirements for terminal equipment (TE) and related access arrangements intended for direct connection to analogue wireline facilities owned by Canadian local exchange carriers (LEC). These technical requirements are intended to protect LEC facilities and personnel from harm. Conformance to these requirements will not ensure compatibility with wireline transmission services.

The technical requirements in this part apply to:

(1) terminal equipment intended for direct connection:

- to the public switched telephone network, for use in conjunction with all analogue services other than party line service;
- to channels furnished in connection with foreign exchange lines; and
- to private line services for tie trunk interfaces and off-premises station lines;

(2) splitters and in-line filters connected to lines equipped with DSL equipment;

(3) secondary telecommunications protector devices (such as protectors or filters installed in power bars) intended for connection between the public switched telephone network interface and terminal equipment; and

(4) component devices intended for connection between the network interface and the terminal equipment (e.g. stuttered dial tone detectors), or for connection between telephone terminal handsets and terminal base units (e.g. receiver amplifiers), or for replacement of handsets or connection to handsets themselves.

1.2 Technical Requirements

1.2.1 Technical Requirements Table

The Technical Requirements Table (Table A) provides a cross-reference between the majority of TE interfaces and the requirements with which they shall comply. These are marked with a single asterisk (*).

An identified requirement shall not apply to equipment which is not capable of providing the function for which the requirement applies.

1.2.2 Technical Requirements for Component Devices

The technical requirements for station equipment component devices intended for direct connection to host equipment are given in Table A. The testing configuration is given in Section 1.5.6.4.

The technical requirements for component devices intended for connection to registered handset telephones are given in Table A. The testing configuration is given in Section 1.5.6.5.

**Table A - Technical Requirements for TE and Protective Circuitry
 to be Connected to Analogue Interfaces**

Requirements	LS	GS	RB	TTA	TTB	OPS	LADC
2.0 Electrical and Mechanical Stresses							
2.1 Mechanical Shock	*	*	*	*	*	*	*
2.2 Dielectric Strength	*	*	*	*	*	*	*
2.3 Hazardous Voltage Limitations							
2.3.1 Requirements	*	*	*	*	*	*	*
2.3.2 Type I E&M Leads				*	*		
2.3.3 Type II E&M Leads				*	*		
2.3.4 Off-premises Station & DID Interfaces Voltages			*			*	
2.3.5 Local Area Data Channel Interfaces							*
2.3.6 Ringdown Voice Band Private Line and Voice Band Metallic Channel Interface	*	*	*	*	*	*	*
2.3.7 Connection of Non-registered Equipment to Registered TE or Registered Protective Circuitry	*	*	*	*	*	*	*
2.3.8 Non-hazardous Voltage Source	*	*	*	*	*	*	*
2.3.9 Ringing Source Limitations						*	*
2.3.10 Hazards Due to Intentional Paths to Ground	*	*	*	*	*	*	*
2.4 Surge Voltage							
2.4.1 Telephone Line Surge - Type A	*	*	*	*	*	*	*

Requirements	LS	GS	RB	TTA	TTB	OPS	LADC
2.4.2 Telephone Line Surge - Type B	*	*	*	*	*	*	*
2.5 Power Line Surge							
2.5.1 Requirements	*	*	*	*	*	*	*
3.0 Network Protection Requirements							
3.1 General	*	*	*	*	*	*	*
3.3 Extraneous AC Energy							
3.3.1 Metallic AC Energy	*	*	*	*	*	*	*
3.3.2 Longitudinal AC Signals	*	*	*	*	*	*	*
3.4 Transmitted Signal Power							
3.4.1 In-band Transmitted Signal Power - Metallic	*	*	*	*	*	*	*
3.4.2 Limitations on Internal Signal Sources Primarily Intended for Network Control Signalling Contained in Voice and Data Equipment	*	*	*	*	*		
3.4.3 Requirements for Data Circuit TE	*	*	*	*	*	*	
3.4.4 Through Transmission	*	*	*	*	*	*	*
3.4.5 DC Conditions to Off-premises Stations (OPS) Lines						*	
3.4.6 Out-of-band Transmitted Signal Power - Metallic	*	*	*	*	*	*	*
3.4.7 For Future Use							
3.4.8 Audio Signal Limiting	*	*	*	*	*	*	
3.4.9 Method Used to Generate Audio Signals							
3.5 Billing Protection							
3.5.1 Call Duration	*	*					
3.5.2 Voice and Data Equipment	*	*					
3.5.3 Signalling Interference	*	*	*	*	*	*	
3.5.4 Answer Supervision			*				
3.6 Transverse Balance	*	*	*	*	*	*	*

Requirements	LS	GS	RB	TTA	TTB	OPS	LADC
3.7 On-hook Terminal Resistance and Impedance							
3.7.1 Metallic and Longitudinal DC Resistance (Loop-start Interface)	*						
3.7.2 DC Current during Ringing (Loop-start and Ground-start Interface)	*	*					
3.7.3 Metallic and Longitudinal Impedance during Ringing (Loop-start and Ground-start Interfaces)	*	*					
3.7.4 OPS Interface for PBX with DID - Ring Trip Requirements						*	
3.8 Idle State Terminal Impedance - Return Loss and Transducer Loss (Tie Trunk Interface)				*	*		
3.9 Automatic Dialling and Automatic Redialling	*	*	*	*	*	*	
3.10 Stuttered Dial Tone Detection	*						
3.11 Manual Programming of Memory Dialling Numbers	*	*					

Note: LS - Loop-start
 RB - Reverse Battery
 TTB - Tie Trunk Type B
 LADC - Local Area Data Channel
 GS - Ground-start
 TTA - Tie Trunk Type A
 OPS - Off-premises Station

1.3 Sequence of Equipment Testing

1.3.1 Overall Sequence

The tests shall be performed in the following order for single or multiple line equipment:

- Section 1.6 Connecting Arrangements
- Section 1.7 Operational Check
- Section 2.2 Dielectric Strength
- Section 3.0 Network Protection Requirements
- Section 2.3 Hazardous Voltage Limitations (without 2.3.10.1)
- Section 2.1 Mechanical Shock
- Section 2.4 Surge Voltage (Type B)
- Section 1.7 Operational Check
- Section 2.2 Dielectric Strength
- Section 3.0 Network Protection Requirements

Section 2.3	Hazardous Voltage Limitations (without 2.3.10.1)
Section 2.4	Surge Voltage (Type A)
Section 2.5	Power Line Surge
Section 1.7	Operational Check
Section 2.2	Dielectric Strength
Section 3.0	Network Protection Requirements
Section 2.3	Hazardous Voltage Limitations

Notes:

- (1) Section 2.2 specifies the requirements for:
 - (a) Environmental conditioning electrical stress prior to the tests of Section 3.0.
 - (b) Hazardous voltage isolation.
- (2) The steady state voltage stress tests specified in Section 2.2 shall be performed prior to the surge voltage requirements of Section 2.4.

1.4 Operating States

TE that is not intended to originate outgoing calls and/or answer incoming calls is considered to be permanently on-hook and shall meet all on-hook requirements, unless specifically exempted, in the respective requirements sections.

Devices with two operating states (i.e. those that have both off-hook and on-hook states) shall comply with the requirements for each of those states. The applicant shall provide, by the manufacturer's operating manual or otherwise, a description of the operating functions that the device is capable of performing in each of the off-hook and on-hook operating states and how the device is put into each of these states. The device shall not automatically change from an on-hook state to an off-hook state except in response to an incoming call, to initiate an outgoing call, or as provided in Sections 3.10 and 3.11.

If feature options are provided that may affect the compliance of parameter values with the requirements of this specification, then each such option shall be tested.

1.5 Testing Configuration

1.5.1 Multi-port TE

- (1) Multi-port TE configured for testing shall include all equipment components necessary to provide the functions described in the manufacturer's operating manual and which can affect compliance with this specification.
- (2) The Multi-port TE shall include:
 - (a) At least one of each type of trunk interface.

- (b) A minimum of one alerting device or alerting detection circuit across each trunk interface having incoming call capability.
 - (c) At least one of each type of station interface. The total number of station interfaces shall equal or exceed the total number of trunk interface types submitted for testing.
 - (d) At least one of each type of station apparatus, including the attendant position intended to be part of the system or a unit of registered station apparatus, to be used for test purposes to demonstrate compliance of the PBX with the requirements of this specification.
- (3) Each trunk interface and station interface submitted for testing shall be terminated in a simulator circuit, a test circuit or a station apparatus as appropriate. See Section 4.0.
 - (4) The Multi-port TE shall permit any trunk interface to be connected to any attendant's position and station interface intended to be accommodated or connected.
 - (5) Multi-port TE shall be tested with a power supply recommended by the manufacturer as being suitable to power the system.

1.5.2 Analogue Network Interfaces with Through Transmission from Digital Network Interfaces

- (1) TE having analogue interfaces with through transmission from digital interfaces shall be configured in a loop-back connection as shown in Figure 1.5.
- (2) Determine from the manufacturer's manual, the permissible voltage level that may be applied to receive 1.544 Mbps (DS-1) digital interface when connected to a transmit interface in a loop-back configuration. Install a suitable resistance pad or other device which may be used to achieve the required input voltage level (e.g. to reduce a 6 V output to match a 3 V input).
- (3) On each unit of TE, select a 1.544 Mbps (DS-1) digital interface which has through path connection to an analogue network interface. Connect the digital interfaces as shown in Figure 1.5, with the voltage level correction if equipped is as specified in (2).

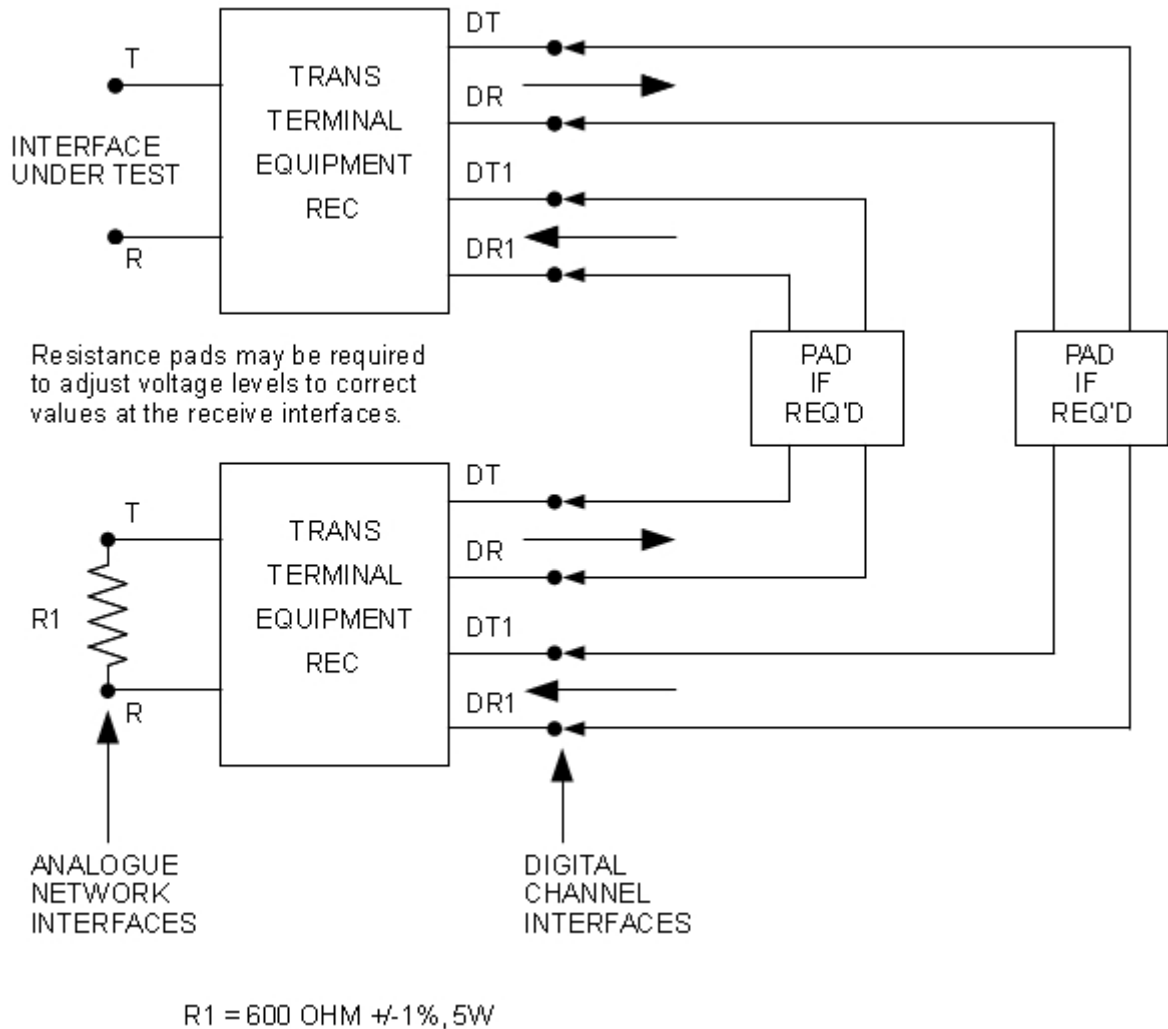

Figure 1.5: Loop-back Digital Channel Interface

1.5.3 Accessory Equipment in TE Packages

Accessory equipment may be included as part of a TE package. The accessory equipment shall be connected to the TE for testing, in accordance with the manufacturer's manual. Such TE packages shall be tested in all operating states for compliance with all applicable requirements of this specification.

1.5.4 Cordless Telephones

The following testing considerations shall apply when cordless telephones are tested to determine compliance with this specification:

- (1) Prior to the start of tests for compliance with CS-03 requirements, the handset battery shall be fully charged according to the manufacturer's instructions.

- (2) The test location shall be selected to minimize any effect on the test results from known sources of electromagnetic interference.
- (3) If applicable, base and handset antennae shall be vertically oriented. In cases where the base unit power cord is used as an antenna, only the power cord supplied with the unit shall be used for test purposes.

1.5.5 Devices Connected in Series with Tip and Ring

Devices connected in series with tip and ring shall be tested “stand alone” to determine compliance with the requirements of this specification.

1.5.6 Component Devices

1.5.6.1 General

This specification makes provision for a wide range of component devices intended to be connected to either:

- (1) host equipment, either directly or via metallic channel, or other types of point-to-point facilities; or
- (2) registered handset telephones.

1.5.6.2 Power Supplies for Component Devices

Component devices shall be tested with a power supply recommended by the manufacturer as being suitable to supply power to the device.

1.5.6.3 Accessory Equipment

Accessory equipment may be included as part of a component devices package. The accessory equipment shall be connected to the component devices for testing, in accordance with the manufacturer's manual. Such component devices packages shall be tested in all operating states for compliance with all applicable requirements of this specification.

1.5.6.4 Station Equipment Component Devices

Component devices intended for connection to an equipment interface shall be assembled together with the host equipment simulator and this assembly shall be tested as TE, using the requirements of Table A.

The following additional requirements shall be met:

- (1) The intended host equipment shall be a currently registered type and shall be clearly identified in the test report.
- (2) An attestation and analysis shall be provided to demonstrate that the host equipment simulator faithfully reproduces the test results that would be obtained with the host equipment.

1.5.6.5 Component Devices Intended for Connection to Registered Handset Telephones

Component devices intended for connection to registered handset telephones shall be tested using a single telephone as a test bed. The telephone selected to be the test bed shall meet the following requirements:

- (1) The telephone shall be representative of the telephones that the component device is intended to be used with.
- (2) The telephone shall consist of a handset connected by means of a cord with modular connectors to the base unit of the telephone.
- (3) The telephone shall be a currently registered device and shall be clearly identified in the test report.
- (4) The component device shall be fully operational when used with the telephone.

The component device shall be assembled together with the telephone set selected as the test bed. This assembly shall be tested as TE, using the requirements of Table A.

1.6 Connecting Arrangements

TE intended for direct electrical connection shall be equipped with a cord and plug or chassis-mounted connector in accordance with CS-03 Part III, identifying the connector codes used. Connectors referred to in Part III may sometimes be used for connections not associated with the network. In such cases the plug shall be labelled to indicate that it is not intended to be connected to the network.

TE submitted for testing shall include all the equipment components necessary to provide the functions described in the manufacturer's operating manual, and which can affect compliance with this specification.

1.7 Operational Check

When directly connected to a laboratory equivalent of the network and to station apparatus, as appropriate, the TE shall be fully operational with respect to the features which are described in the manufacturer's instruction manual and which are necessary to perform the tests in Section 3.0. When the operational checks are repeated after the application of the electrical stress of Section 2.0, it is permissible for the TE to be partly or fully inoperable.

1.8 Ringer Equivalence Numbers

The Ringer Equivalence Number (REN) for a TE is the value determined below as appropriate:

For individual equipment intended for operation on loop-start and ground-start telephone facilities, the following quotients shall be formed:

Five times the impedance limitation listed in Table 3.7(a), divided by the minimum measured AC impedance, as defined in Section 3.7.3.2, during the application of simulated ringing as listed in Table 3.7(a).

2.0 Electrical and Mechanical Stresses

2.1 Mechanical Shock

2.1.1 Requirements

TE and network protection devices, unpackaged, shall comply with all the requirements specified in Sections 2.0 and 3.0 both prior to and after the application of all of the mechanical stresses specified in this section, notwithstanding that some of these stresses may result in partial or total destruction of the equipment.

- (1) Hand-held items normally used at head height: 18 random drops from a height of 1.5 m onto concrete covered with 3 mm asphalt tile or similar surface.
- (2) Tabletop (desktop) equipment 0-5 kilograms: six random drops from a height of 750 mm onto concrete covered with 3 mm asphalt tile or a similar surface.

2.1.2 Method of Measurement

- (1) TE and protective circuitry equipment unpackaged:
 - (a) Hand-held items normally used at head height: 18 random drops from a height of 1.5 m onto concrete covered with 3 mm asphalt tile or similar surface.
 - (b) Tabletop (desktop) top equipment (0-5 Kg): these tests are made onto concrete covered with 3 mm asphalt tile or a similar surface; one 750 mm face drop on each normal or designated rest face; one 750 mm drop on all other faces; and one 750 mm corner drop on each corner.
- (2) The drop tests specified in the mechanical shock conditioning stresses shall be performed as follows:

Face Drop -	The unit shall be dropped such that the face which is to be struck is approximately parallel to the impact surface.
Corner Drop -	The unit shall be dropped such that upon impact, a line from the struck corner to the centre of gravity of the packaged equipment is approximately perpendicular to the impact surface.
Edgewise Drop -	The unit shall be positioned on a flat test surface. One edge of the rest face shall be supported with a block so that the rest face makes an angle of 20 degrees with the horizontal. The opposite edge shall be lifted the designated height above the test surface and dropped.

Cornerwise Drop - The unit shall be positioned on a flat test surface. One corner of the rest face shall be supported with a block so that the rest face makes an angle of 20 degrees with the horizontal. The opposite corner should be lifted the designated height above the test surface and dropped.

Random Drop - The unit shall be positioned prior to release to ensure as nearly as possible that for every six drops there is one impact on each of the six major surfaces, and that the surface which is to be struck is approximately parallel to the impact surface.

2.2 Dielectric Strength

2.2.1 Requirements

TE shall have a voltage applied to the following combination of points listed in Table 2.2. The test voltage shall be 50-60 Hz AC:

- (1) all telephone connections;
- (2) all power connections;
- (3) all possible combinations of exposed conductive surfaces on the exterior of such equipment or circuitry, including grounding connection points but excluding terminals for connection to other TE;
- (4) all terminals for connection to registered protective circuitry or non-registered equipment;
- (5) all auxiliary lead terminals;
- (6) all E&M lead terminals; and
- (7) all PR, PC, CY1 and CY2 leads.

Gradually increase the voltage from zero to the values listed in Table 2.2 over a 30-second time period, then maintain the voltage for one minute. The current through the points shall not exceed 10 mA peak at any time during this 90-second interval.

Equipment states necessary for compliance with the requirements of this section that cannot be achieved by normal means of power, shall be achieved artificially by appropriate means.

Table 2.2 - Voltage Applied for Various Combinations of Electrical Connections

Voltage source connected between:	Vac rms*
(1) and (2)	1500
(1) and (3) (see notes 1 and 2)	1000
(1) and (4) (see note 2)	1000
(1) and (5) (see note 2)	1000
(1) and (5) (see note 2)	1000
(1) and (6) (see note 2)	1000
(2) and (3) (see note 1)	1500
(2) and (4)	1500
(2) and (5)	1500
(2) and (6)	1500
(2) and (7)	1500
(3) and (5) (see notes 1 and 2)	1000
(3) and (6) (see notes 1 and 2)	1000
(4) and (5) (see note 2)	1000
(4) and (6) (see note 2)	1000
(5) and (6) (see note 2)	1000

*Value to which test voltage is gradually increased.

Notes:

(1) A telephone connection, auxiliary lead, or E&M lead that has an intentional DC conducting path to earth ground at operational voltages (such as a ground-start lead), may be excluded from this requirement in that operational state. Leads excluded for this reason shall comply with the requirements of Section 2.3.10.1.

A telephone connection, power lead, auxiliary lead, or E&M lead that has an intentional DC conducting path to earth ground for protection purposes at the leakage current test voltage (such as through a surge suppressor), may have the component providing the conducting path removed from the equipment for the leakage current test in that operational state. Components removed for this reason shall comply with the requirements of Section 2.3.10.2.

- (2) For multi-unit equipment interconnected by cables that is evaluated and registered as an interconnected combination or assembly, the specified 10 mA peak maximum leakage current limitation, other than between power connection points and other points, may be increased as described here to accommodate cable capacitance. The leakage current limitation may be increased to $(10N+0.13L)$ mA peak where L is the length of the interconnecting cable in the leakage path in metres and N is the number of equipment units that the combination or assembly will place in parallel across a telephone connection.
- (3) RF filters and surge protectors on the line side of power supplies may be disconnected before making dielectric strength measurements. As an alternative to disconnecting these filters and surge protectors, this measurement may be made using a DC voltage equal to the peak AC test voltage.

2.2.2 Method of Measurement

Warning - Adequate safety precautions should be observed!

- (1) Connect the TE to the test circuit of Figure 2.2.
- (2) Select the appropriate TE test points and connect to the output of the test setup.
- (3) Place the TE in the first test state.
- (4) Over a 30-second interval, the test voltage level shall be gradually increased from zero to the level required for the connections under test. The maximum voltage level shall be maintained for an additional 60 seconds.
- (5) Monitor the resulting current and the applied voltage level for the 90-second test period.
- (6) Record the maximum current measured during this period.
- (7) Adjust the source for zero-volt output.
- (8) Repeat steps (4) to (7) for all applicable operational states.
- (9) Repeat steps (2) to (8) for all specified combinations of electrical connections as listed in Table 2.2.

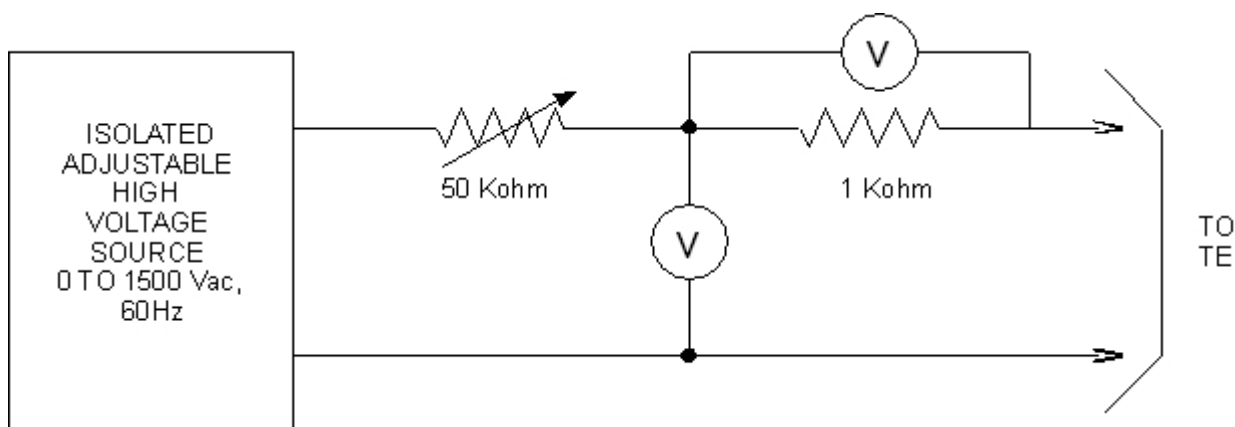

Figure 2.2: Dielectric Strength Test Circuit

Notes:

- (1) A 1500 Vac voltmeter or a resistive voltage divider and high-input impedance voltmeter may be used.
- (2) A true rms voltmeter may be used to measure a converted rms current limit. Alternatively, an oscilloscope may be used to measure peak current. Precautions should be taken for isolation of high-voltage differential or current probes.
- (3) The 50-kilohm current-limiting resistor is optional but is recommended to reduce the possibility of damage in case of insulation breakdown.

2.3 Hazardous Voltage Limitations

2.3.1 Requirements

Under no conceivable condition of TE failure during handling, operation or repair of such equipment or circuitry, shall the open circuit voltage on telephone connections exceed 70 V peak after one second, except for voltages for network control signalling, alerting and supervision.

2.3.2 Type I E&M Leads

TE on the “A” or “B” side of the interface (see Figures 4.7 (a) and 4.7 (b)) shall comply with the following requirements:

- (1) The DC current on the E lead shall not exceed 100 mA.
- (2) The maximum DC potentials to ground shall not exceed the values given in Table 2.3(a) when measured across a resistor of 20 kohms \pm 10 %.
- (3) The maximum AC potential between E&M leads and ground reference shall not exceed 5 V peak.

- (4) M lead protection shall be provided to ensure that voltages to ground do not exceed 60 V. For relay contact implementation, a power dissipation capability of 0.5 watts shall be provided in the shunt path.

Table 2.3(a) - Type I E&M

	E Lead	M Lead
TE on “B” side originates signals to network on E lead	± 5 V	± 5 V
TE on “A” side originates signals to network on M lead	-56.5 V; no positive potential w.r.t. ground	-56.5 V; no positive potential w.r.t. ground

- (5) If the TE contains an inductive component in the E lead, it must ensure that the transient voltage across the contact, as a result of a relay contact opening, does not exceed the following voltage and duration limitations:
- (a) 300 V peak;
 - (b) a rate of change of one volt per microsecond; and
 - (c) a 60 V level after 20 ms.

2.3.2.1 Method of Measurement

For TE intended to be connected to Type A or B tie trunks with Type I E&M signalling, which signals to the network on the E lead, A side:

- (1) E lead DC current to ground:

- (a) Connect the TE as shown in Figure 2.3(a).
- (b) Operate switch S1 to position “b”, switch S2 to position “a”, switch S3 to position “b”.
- (c) Set the multi-metre to the DC ammeter function.
- (d) Measure the DC current from the E lead to ground.

- (2) E lead DC voltage to ground:

- (a) Connect the TE as shown in Figure 2.3(a).
- (b) Operate switch S2 to position “a”, switch S3 to position “a”.
- (c) Set the multi-metre to the DC voltage function.
- (d) Operate switch S1 to position “b”.
- (e) Measure the DC potential between the E lead and ground with the E lead switch in the TE in both the open and closed states.
- (f) Repeat step (e) for all other off-hook states of the TE.

(3) E lead AC voltage to ground:

- (a) Connect the TE as shown in Figure 2.3(a).
- (b) Operate switch S2 to position “a”, switch S3 to position “a”.
- (c) Set the multi-metre to the AC voltage function.
- (d) Operate switch S1 to position “b”.
- (e) Measure the AC potential between the E lead and ground with the E lead switch in the TE in both the open and closed states.
- (f) Repeat step (e) for other off-hook states of the TE.

Note: Repeat steps (2) and (3) and measure the DC and AC voltages at the E lead on the “B” side.

(4) Contact Protection (only if E lead detector on the A side is inductive):

- (a) Verify by examination that protection is provided across the relay winding so as to limit the peak voltage to 300 volts.
 - (b) The rate of change of voltage is 1 V/ μ s.
 - (c) The voltage levels off to 60 volts or less after 10 ms.
- or:
- (a) Connect the TE to the test circuit of Figure 2.3(b).
 - (b) Open switch S1 and record the oscilloscope trace.

For TE intended to be connected to Type A or B tie trunks with Type I E&M signalling, which signals to the network on the M lead, A side:

(1) M lead DC voltage to ground:

- (a) Connect the TE as shown in Figure 2.3(a).
- (b) Operate switch S2 to position “a”, switch S3 to position “a”.
- (c) Set the multi-metre to the DC voltage function.
- (d) Operate switch S1 to position “a”.
- (e) Measure the DC potential between the M lead and ground with the M lead switch in the TE in both the open and closed states.
- (f) Repeat step (e) for other off-hook states of the TE.

(2) M lead AC voltage to ground:

- (a) Connect the TE as shown in Figure 2.3(a).
- (b) Operate switch S2 to position “a”, switch S3 to position “a”.
- (c) Set the multi-metre to the AC voltage function.
- (d) Operate switch S1 to position “a”.
- (e) Measure the AC potential between the M lead and ground with the E lead switch in the TE in both the open and closed states.
- (f) Repeat step (e) for other off-hook states of the TE.

Note: Repeat steps (1) and (2) and measure the DC and AC voltages at the M lead on the “B” side.

(3) M lead surge suppression:

Examine a schematic of the E&M circuit and determine if means are provided to limit the DC voltage to ground to 60 volts while giving a power dissipation of 0.5 watts.

2.3.3 Type II E&M Leads

TE shall comply with the following requirements:

- (1) For TE on the “A” side of the interface, the DC current in the E lead shall not exceed 100 mA. The maximum AC potential between the E lead and ground shall not exceed 5 V peak.
- (2) For TE on the “B” side of the interface, the DC current in the SB lead shall not exceed 100 mA. The maximum AC potential between the E lead and ground shall not exceed 5 V peak.
- (3) The maximum DC potentials to ground shall not exceed the values in Table 2.3(b) when measured across a resistor of 20 kohms \pm 10%.

Table 2.3(b) - Type II E&M

	E lead	M lead	SB lead	SG lead
TE on “B” side of the interface originates signals to network on E lead.	± 5 V	± 5 V	-56.5V; no positive potential w.r.t. ground	± 5 V
TE on “A” side of interface originates signals to network on M lead.	-56.5V; no positive potential w.r.t. ground	± 5 V	± 5 V	± 5 V

- (4) The maximum AC potential to ground shall not exceed 5V peak on the following leads, from sources in the TE:
 - (a) M, SG and SB leads for TE on the “A” side of the interface;
 - (b) E, SG and M leads for TE on the “B” side of the interface.
- (5) If the TE contains an inductive component in the E or M lead, it must ensure that the transient voltage across the contact as a result of a relay contact opening does not exceed the following voltage and duration limitations:
 - (a) 300 V peak;
 - (b) a rate of change of one volt per microsecond; and
 - (c) a 60 V level for more than 20 ms.

2.3.3.1 Method of Measurement

For TE intended to be connected to Type A or B tie trunks with Type II E&M signalling, which signals to the network on the E lead and SG lead, A side:

(1) E lead DC current to ground:

- (a) Connect the TE as shown in Figure 2.3(a).
- (b) Operate switch S1 to position “b”, switch S2 to position “a”, switch S3 to position “b”.
- (c) Set the multi-metre to the DC ammeter function, grounding the E lead.
- (d) Measure the DC current from the E lead to ground.

Note: Repeat the procedures in step (1) and measure the DC current with the SG lead grounded on the “B” side.

(2) E lead, SG lead, DC voltage to ground:

- (a) Connect the TE as shown in Figure 2.3(a).
- (b) Operate switch S2 to position “a”, switch S3 to position “a”.
- (c) Set the multi-metre to the DC voltage function.
- (d) Operate switch S1 to position “b”.
- (e) Measure the DC potential between the lead and ground with the lead switch in the TE in both the open and closed states.
- (f) Repeat step (e) for all other off-hook states of the TE.
- (g) Operate switch S1 to position “e”.
- (h) Repeat step (e).

(3) E lead, SG lead, AC voltage to ground:

- (a) Connect the TE as shown in Figure 2.3(a).
- (b) Operate switch S2 to position “a”, switch S3 to position “a”.
- (c) Set the multi-metre to the AC voltage function.
- (d) Operate switch S1 to position “b”.
- (e) Measure the AC potential between the lead and ground with the lead switch in the TE in both the open and closed states.
- (f) Repeat step (e) for all other off-hook states of the TE.
- (g) Operate switch S1 to position “e”.
- (h) Repeat step (e).

Note: Repeat steps (1) and (2) and measure the DC and AC voltages at the E lead and SG lead on the “B” side.

(4) Contact Protection (only if E lead detector on the A side is inductive):

- (a) Verify by examination that protection is provided across the relay winding so as to limit the peak voltage to 300 volts.
- (b) The rate of change of voltage is $1 \text{ V}/\mu\text{s}$.
- (c) The voltage levels off to 60 volts or less after 20 ms.
or:
 - (a) Connect the TE to the test circuit of Figure 2.3(b).
 - (b) Open switch S1 and record the oscilloscope trace.

Note: Repeat the measurements in step (4) for the M lead, B side.

For TE intended to be connected to Type A or B tie trunks with Type II E&M signalling, which signals to the network on the M lead and SB lead, A side:

(1) M lead, SB lead, DC voltage to ground:

- (a) Connect the TE as shown in Figure 2.3(a).
- (b) Operate switch S2 to position “a”, switch S3 to position “a”.
- (c) Set the multi-metre to the DC voltage function.
- (d) Operate switch S1 to position “a”.
- (e) Measure the DC potential between the M lead and ground with the M lead switch in the TE in both the open and closed states.
- (f) Repeat step (e) for all other off-hook states of the TE.
- (g) Operate switch S1 to position “d”.
- (h) Repeat step (e).

(2) M lead, SB lead, AC voltage to ground:

- (a) Connect the TE as shown in Figure 2.3(a).
- (b) Operate switch S2 to position “a”, switch S3 to position “a”.
- (c) Set the multi-metre to the AC voltage function.
- (d) Operate switch S1 to position “a”.
- (e) Measure the AC potential between the M lead and ground with the M lead switch in the TE in both the open and closed states.
- (f) Repeat step (e) for all other off-hook states of the TE.
- (g) Operate switch S1 to position “d”.
- (h) Repeat step (e).

Note: Repeat steps (1) and (2) and measure the DC and AC voltages at the M lead on the “B” side.

2.3.3.2 Summary of Measurements

Table 2.3(c) - E&M Leads to be Tested

Interface Type		Type I				Type II							
		A		B		A				B			
Side of the interface		E	M	E	M	E	SG	M	SB	E	SG	M	SB
Lead to be tested		E	M	E	M	E	SG	M	SB	E	SG	M	SB
1	DC Current to Ground	X				X							X
2	AC Volts to Ground	X	X	X	X	X	X	X	X	X	X	X	X
3	DC Volts to Ground	X	X	X	X	X	X	X	X	X	X	X	X
4	Open Circuit Volts toGground												
5	Surge Suppression		X										
6	Contact Protection	X				X						X	

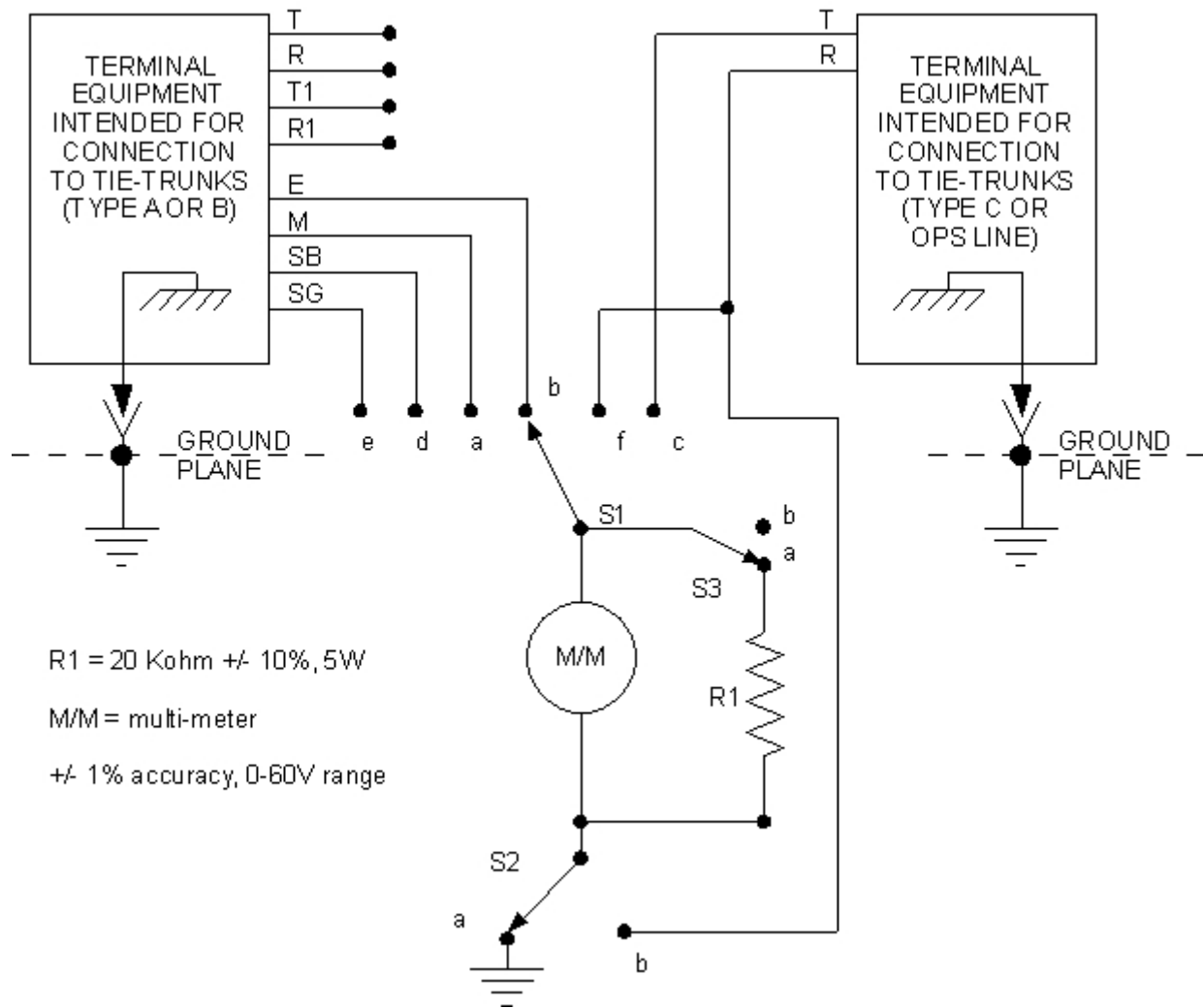

Figure 2.3(a): Metallic Potential Test Circuit

Notes:

- (1) The input resistance of the voltmeter shall not be less than 200 kohms.
- (2) When the TE makes provision for an external connection to ground (G), the TE shall be connected to ground. When the TE makes no provision for an external ground, the TE shall be placed on a ground plane which is connected to ground and has overall dimensions at least 50% greater than the corresponding dimensions of the TE. The TE shall be centrally located on the ground plane without any additional connection to ground.

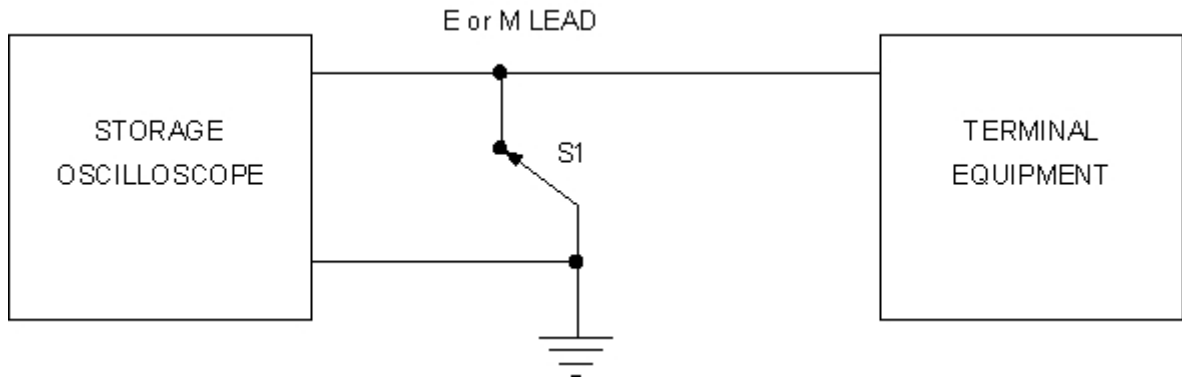

Figure 2.3(b): E or M Lead Contact Protection

Note: S1 consists of the contacts of a relay which are designed to be free of contact bounce, such as are provided in a mercury-wetted relay.

2.3.4 Off-premises Station and Direct Inward Dialling (DID) Interfaces Voltages

(1) Talking battery or voltages applied by a PBX (or similar systems) to OPS and DID interface leads for supervisory purposes must be negative with respect to ground, shall not exceed -56.5 volts DC, and shall not have a significant AC component.*

* The AC component should not exceed 5 volts peak where not otherwise specified in Section 3.4.

(2) Ringing signals applied by a PBX (or similar systems) to OPS interface leads shall comply with requirements in paragraph 2.3.9.4 of this section. Ringing voltages shall be applied between the ring conductor and ground.

2.3.4.1 Method of Measurement

For TE intended to be connected to OPS lines or DID Trunks:

(1) Tip to ring, tip to ground, ring to ground, DC measurements:

- (a) Connect the TE as shown in Figure 2.3(a).
- (b) Operate switch S1 to position “c”, switch S2 to position “b”, and switch S3 to position “b”.
- (c) Set the multi-metre function to DC volts.
- (d) Measure the DC potential across tip and ring.
- (e) Operate switch S2 to position “a”.
- (f) Measure the DC potential between tip and ground.
- (g) Operate switch S1 to position “f”.
- (h) Measure the DC potential between ring and ground.
- (i) Repeat steps (c) to (h) for all other on-hook states of the TE.

(2) Tip to ring, tip to ground, ring to ground, applied ringing, AC measurements (OPS Line):

- (a) Connect the TE as shown in Figure 2.3(a).
- (b) Operate switch S1 to position “c”, switch S2 to position “b”, and switch S3 to position “b”.
- (c) Set the multi-metre function to AC volts.
- (d) Measure the AC potential across tip and ring.
- (e) Operate switch S2 to position “a”.
- (f) Measure the AC potential between tip and ground.
- (g) Operate switch S1 to position “f”.
- (h) Measure the AC potential between ring and ground.
- (i) Repeat steps (c) to (h) for all other on-hook states of the TE including applied ringing.

Note: Perform the tests specified in Section 2.3.9 to verify compliance with ringing source requirements.

2.3.4.2 Summary of Measurements

(1) In the idle open circuit state, measure the DC voltage with the DC voltmeter connected between:

- (a) tip and ring;
- (b) tip and ground; and
- (c) ring and ground.

(2) In the idle open circuit state, measure the extraneous AC voltage with an AC voltmeter connected between:

- (a) tip and ring;
- (b) tip and ground; and
- (c) ring and ground.

(3) In the ringing open circuit state, confirm that the ringing signal is applied to the proper lead by measuring the AC voltage with the AC voltmeter connected between:

- (a) tip (OPS) and ground - for OPS leads only; and
- (b) ring (OPS) and ground - for OPS leads only.

(4) Perform tests specified in Section 2.3.9 to verify compliance with ringing source requirements.

2.3.5 Local Area Data Channel Interfaces

For Local Area Data Channel interfaces, during normal operating modes including terminal equipment initiated maintenance signals, approved terminal equipment shall ensure, except during the application of ringing (limitations specified in Section 2.3.9), with respect to telephone connections (tip, ring, tip-1, ring-1) that:

- (1) Under normal operating conditions, the rms current per conductor between short-circuited conductors, including DC and AC components, does not exceed 350 mA. For other than normal operating conditions, the rms current between any conductor and ground or between short circuited conductors, including DC and AC components, may exceed 350 mA for no more than 1.5 minutes;
- (2) The DC voltage between any conductor and ground does not exceed 60 V. Under normal operating conditions, it shall not be positive with respect to ground (though positive voltages up to 60 V may be allowed during brief maintenance states);
- (3) AC voltages are less than 42.4 VP between any conductor and ground. Terminal equipment shall comply while other interface leads are:
 - (a) Unterminated, and
 - (b) Individually terminated to ground.

Note: Combined AC and DC voltages between any conductor and ground shall be less than 42.4 VP when the absolute value of the DC component is less than 21.2 V; and less than $(32.8 + 0.454 \times V \text{ DC})$ when the absolute value of the DC component is between 21.2 and 60 V.

2.3.5.1 Method of Measurement

Warning - Adequate Safety Precautions Should Be Observed!

- (1) Place TE in first operating state.
- (2) Connect current meter between T and R leads of the TE and measure combined AC and DC short circuit current.
- (3) Repeat step (2) with current meter between T and ground and between R and ground.
- (4) Repeat steps (1) to (3) for the T1 and R1 pair of the TE if testing a 4-wire interface.
- (5) Connect DC voltmeter between T and ground and measure voltage.
- (6) Repeat step (5) with voltmeter between R and ground.
- (7) Repeat steps (5) and (6) for the T1 and R1 pair if testing a 4-wire interface.
- (8) Connect oscilloscope between T lead and ground, and measure AC peak and combined AC peak and DC voltages with other network leads unterminated.
- (9) Repeat step (8) with oscilloscope between R and ground.
- (10) Repeat steps (8) and (9) for the T1 and R1 pair if testing a 4-wire interface.
- (11) Repeat steps (8) to (10) for AC peak voltage only with other network leads individually terminated to ground.

(12) Repeat steps (2) to (11) for other modes of operation.

2.3.6 Ringdown Voice Band Private Line and Voice Band Metallic Channel Interface

During normal operation, TE intended for connection to ringdown voice band private line interfaces or voice band metallic channel interfaces shall ensure that:

- (1) Ringing voltage does not exceed the voltage and current limits specified in paragraph 2.3.9.4, and is:
 - (a) applied to the ring conductor with the tip conductor grounded for 2-wire interfaces; or
 - (b) simplexed on the tip and ring conductors with ground simplexed on the tip_1 and ring_1 conductors for 4-wire interfaces.
- (2) Except during the signalling mode or for monitoring voltage, there is no significant positive DC voltage (not over +5 volts) with respect to ground: (a) for 2-wire ports between the tip lead and ground and the ring lead and ground, and (b) for 4-wire ports between the tip lead and ground, the ring lead and ground, the tip_1 lead and ground, and the ring_1 lead and ground.
- (3) The DC current per lead under short-circuit conditions shall not exceed 140 mA.

2.3.6.1 Method of Measurement

Warning - Adequate safety precautions should be observed!

- (1) Inspect the appropriate circuit diagrams to verify the following:
 - (a) Ringing voltage is used for alerting only.
 - (b) Ringing voltage is applied to the ring lead with the tip lead grounded for 2-wire interfaces.
 - (c) Ringing voltage is simplexed on the tip and ring leads, and ground is simplexed on the T1 and R1 leads for 4-wire interfaces.
- (2) Perform tests specified in Section 2.3.9 to verify compliance with the ringing source requirements in the signalling state.
- (3) Place the TE in the idle state.
- (4) Connect a DC voltmeter between tip lead and ground of the TE and measure the voltage, noting the polarity.
- (5) Repeat step (4) for the ring lead.
- (6) Repeat step (4) for T1 and R1 leads of the TE if testing a 4-wire interface.
- (7) Repeat steps (4) to (6) with the TE in the talk state.
- (8) Place the TE in the idle state.

- (9) Connect a current metre between the tip and ring leads and measure the short circuit current.
- (10) Repeat step (9) between the tip lead and ground and between the ring lead and ground.
- (11) Repeat step (9) for T1 and R1 leads if testing a 4-wire interface.
- (12) Repeat steps (9) to (11) for the talk state.

2.3.7 Connection of Non-registered Equipment to Registered TE or Protective Circuitry

2.3.7.1 Conducting Paths to Telephone Connections, Auxiliary Leads and E&M Leads

Leads or any elements having a conducting path to telephone connections, auxiliary leads or E&M leads shall:

- (1) Be reasonably physically separated and restrained from, and be neither routed in the same cable as, nor use the same connector as leads or metallic paths connecting power connections.
- (2) Be reasonably physically separated and restrained from, and be neither routed in the same cable as, nor use adjacent pins on the same connector as metallic paths to lead to non-registered equipment, when specification details do not show that interface voltages are less than non-hazardous voltage source limits in Section 2.3.8.

2.3.7.2 Method of Measurement

Warning - Adequate safety precautions should be observed!

- (1) Inspect schematic diagram and identify leads for connection to the network interface, including telephone connections, auxiliary leads and E&M leads. Also identify power leads to non-registered TE.

Note: Leads in this case refer to any type of metallic connection.

- (2) Identify leads to non-registered TE with hazardous voltages.
- (3) Inspect equipment to verify that leads for connection to the network are adequately separated from power leads and from leads to non-registered TE with hazardous voltages.
- (4) Verify that leads for connection to the network are not routed in the same cable and do not use the same connector as power leads or leads to non-registered TE with hazardous voltages.
- (5) If leads for connection to the telephone network are in the same connector with leads to non-registered TE with hazardous voltages, verify that they are not on adjacent pins.

2.3.8 Non-hazardous Voltage Source

A voltage source is considered a non-hazardous voltage source if it conforms with the requirements of Section 2.2 and either 2.4 or 2.5 of this document, with all connections to the source, other than primary power connections, treated as “telephone connections”, and if such source supplies voltages no greater than the following under all modes of operation and of failure:

- (1) AC voltages less than 42.4 V peak;
- (2) DC voltages less than 60 V; and
- (3) combined AC and DC voltages less than 42.4 V peak when the absolute value of the DC component is less than 21.2 V, and less than $(32.8 + 0.454 \times V_{dc})$ when the absolute value of the DC component is between 21.2 and 60 V.

2.3.9 Ringing Source Limitations

Ringing sources for all Classes of OPS interfaces shall meet all of the following requirements:

2.3.9.1 Ringing Signal Frequency

The ringing signal shall use only frequencies whose fundamental component is equal to or below 70 Hz.

2.3.9.2 Ringing Signal Voltage

The ringing voltage shall be less than 300 V peak-to-peak and less than 200 V peak-to-ground across a resistive termination of at least 1 Mohm.

2.3.9.3 Ringing Signal Interruption Rate

The ringing voltage shall be interrupted to create quiet intervals of at least one second (continuous) duration, each separated by no more than 5 seconds. During the quiet intervals, the voltage to ground shall not exceed the voltage limits given in paragraph (1) of Section 2.3.4.

2.3.9.4 Ringing Signal Sources

Ringing voltage sources shall comply with the following requirements:

- (1) If the ringing current through a 500 ohm (and greater) resistor does not exceed 100 mA peak-to-peak, neither a ring trip device nor a monitoring voltage are required.
- (2) If the ringing current through a 1500 ohm (and greater) resistor exceeds 100 mA peak-to-peak, the ringing source shall include a current-sensitive ring trip device in series with the ring lead that will trip ringing as specified in Figure 2.3(c) and Table 2.3(d), in accordance with the following conditions:
 - (a) If the ring trip device operates as specified in Figure 2.3(c) and Table 2.3(d) with $R = 500$ ohms (and greater), no monitoring voltage is required.

- (b) If, however, the ring trip device only operates as specified in Figures 2.3(c) and Table 2.3(d) with $R = 1500$ ohms (and greater), then the ringing voltage source shall also provide a monitoring voltage between 19 Vdc and 56.5 Vdc, negative with respect to ground, on the tip or ring conductor.
- (3) If the ringing current through a 500 ohm (and greater) resistor exceeds 100 mA (peak-to-peak) but does not exceed 100 mA peak-to-peak with 1500 ohm (and greater) termination, the ringing voltage source shall include either a ring trip device that meets the operating characteristics specified in Figure 2.3(c) and Table 2.3(d) with 500 ohms (and greater), or a monitoring voltage as specified in (b) above.

Note: If the operating characteristics specified in Figure 2.3(c) and Table 2.3(d) are not met with both the 500 ohm and 1500 ohm terminations, then the TE under test fails.

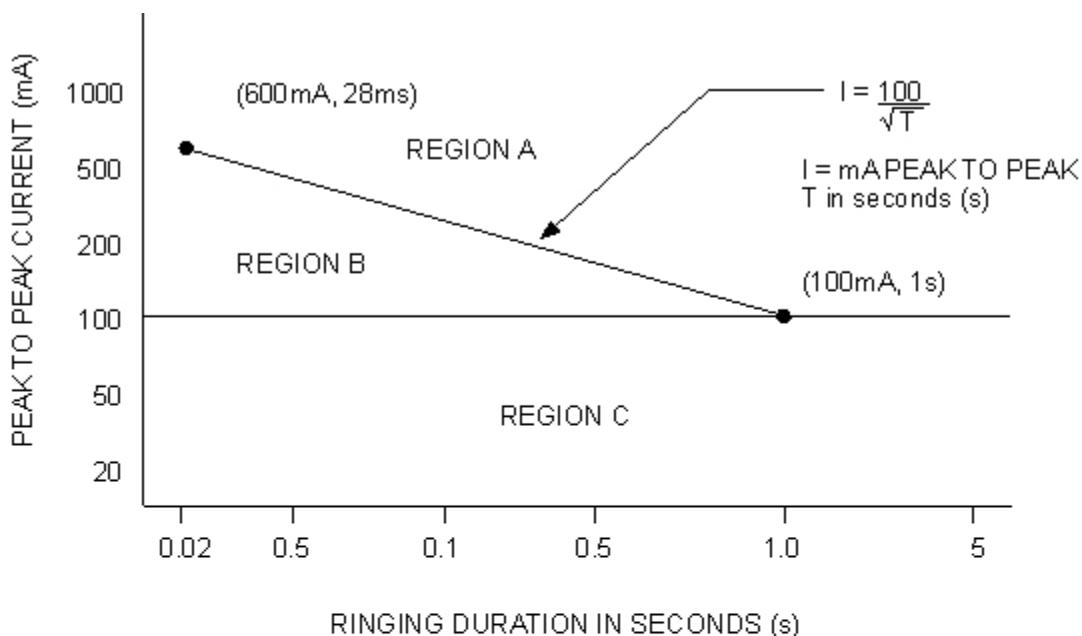

CURRENT THROUGH		REQUIREMENT
500 Ohm	1500 Ohm	
A	A	NOT PERMITTED
A	B	TRIP DEVICE AND MONITOR VOLTAGE
B	B	TRIP DEVICE
A or B	C	TRIP DEVICE AND MONITOR VOLTAGE
C	C	NONE

Figure 2.3(c): Ringing Protection

Table 2.3(d) - Summary of Ring Trip Requirements

Requirements (From 2.3.9.4)	Ringing Current (mA p.p)		Function Required		Ring Trip Device Operates per Figure 2.3(c)
	R=500 ohms & Greater	R=1500 ohms & Greater	Ring Trip	Monitor Voltage	
(1)	< 100	< 100	Optional	Optional	Optional
(2) (a)	N/A	> 100	Yes	Optional	Yes for both resistance
(2) (b)	N/A	> 100	Yes	Yes	Yes for R=1500 ohms & greater No for R=500 ohms & greater
(3)	> 100	< 100	Either ring trip device or monitor voltage required		Yes for R=500 ohms & greater, if ring trip device is used

2.3.9.5 Method of Measurement

Warning - Adequate safety precautions should be observed!

- (1) Connect the frequency counter to the tip and ring leads of the TE and measure the frequency of the ringing voltage.
- (2) If the TE is a 4-wire device, connect the frequency counter to the tip and ring leads of the TE tied together, and to the T1 and R1 leads of the TE, and measure the frequency of the ringing voltage.
- (3) Connect the TE to the test circuit of Figure 2.3(d) if the TE is a 2-wire device or to the test circuit of Figure 2.3(e) if the TE is a 4-wire device.

Note: A 10x probe should be used.

- (4) Set switch S1 to “a” and measure:
 - (a) peak-to-peak ringing voltage;
 - (b) peak-to-ground ringing voltage;
 - (c) ringing time interval;
 - (d) non-ringing time interval.
- (5) Set switch S1 to position “b” and initiate ringing.

- (6) Measure and record the peak-to-peak voltage.
- (7) If ringing is tripped, measure the duration of applied ringing.
- (8) Convert the voltage recorded in step (6) to peak-to-peak current in mA.
- (9) Set switch S1 to position “c” and repeat steps (5) to (8).
- (10) Refer to the table in Figure 2.3(c) to determine compliance with ringing voltage and the need for a tripping device and a monitoring voltage.

Note: The peak-to-peak current and the time duration of the current measured through the 500 ohm and 1500 ohm resistors in steps (5) to (9) are used in this determination.

- (11) If a monitoring voltage is required, connect the oscilloscope (DC coupled), using the 10X probe, to measure the DC voltage present during the ringing and non-ringing states.

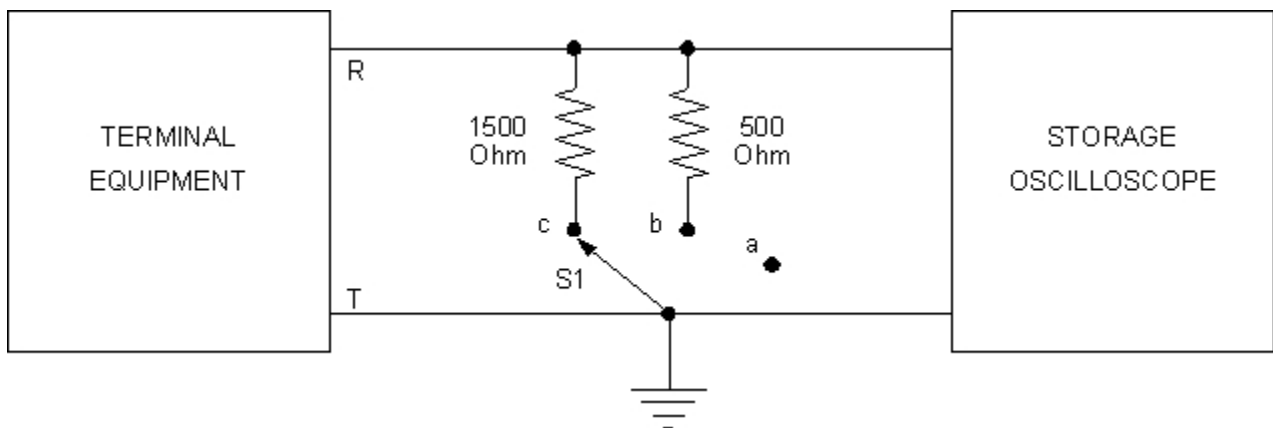

Figure 2.3(d): Ringing Sources, 2-Wire

Note: A 10x probe is normally used to obtain the reading. The input impedance of the probe should be equal to or greater than 1 Mohm.

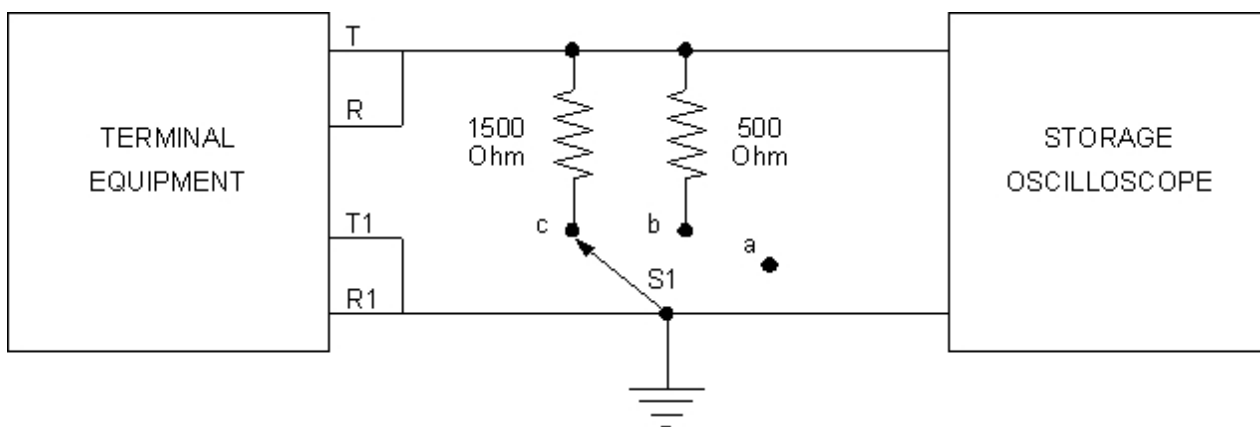

Figure 2.3(e): Ringing Sources, 4-Wire

Note: A 10x probe is normally used to obtain the reading. The input impedance of the probe should be equal to or greater than 1 Mohm.

2.3.10 Hazards Due to Intentional Paths to Ground

2.3.10.1 Connections with Operational Paths to Ground

TE having an intentional DC conducting path to earth ground at operational voltages that was excluded during the dielectric strength test of Section 2.2 shall have a DC current source derived from a low-voltage current source not exceeding 12 V, applied between the following points:

- (1) Telephone connections, including tip, ring, tip_1, ring_1, E&M leads and auxiliary leads; and
- (2) Earth grounding connections.

For each test point, gradually increase the current from zero to 1 A, then maintain the current for one minute. The voltage between (1) and (2) shall not exceed 0.1 V at any time.

Note: In the event that there is a component or circuit in the path to ground, the requirement shall be met between the grounded side of the component or circuit and the earth grounding connection.

2.3.10.1.1 Method of Measurement

- (1) Connect the TE to the test circuit of Figure 2.3(f).
- (2) Connect the current source between the intentionally grounded telephone connection and the earth grounding connection.
- (3) Gradually increase the current from zero to 1A and maintain this current for one minute.
- (4) Monitor and record the voltage drop across the connections under test. Verify that the voltage does not exceed 0.1 volt at any time.

(5) Repeat steps (2) to (4) for each applicable connection.

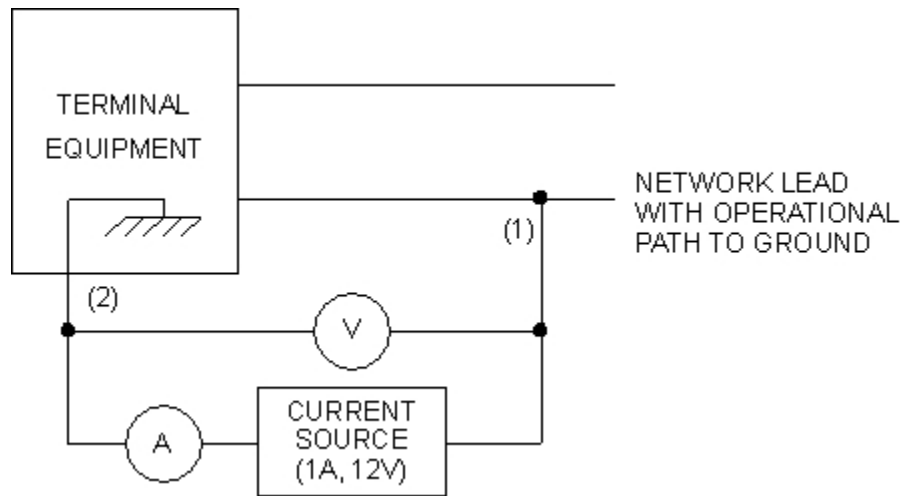

Figure 2.3(f): Intentional Operational Paths to Ground

2.3.10.2 Connections with Protection Paths to Ground

TE having an intentional DC conducting path to earth ground for protection purposes at the leakage current test voltage that was removed during the longitudinal steady state voltage test of 2.2.1 shall have a 60 Hz voltage source applied between the following points:

- (1) Simplex telephone connections, including tip and ring, tip_1 and ring_1, E&M leads and auxiliary leads; and
- (2) Earth grounding connections.

Gradually increase the voltage from zero to 120 Vrms for TE, or 300 Vrms for protective circuitry, and then maintain the voltage for one minute. The current between (1) and (2) shall not exceed 10 mA peak at any time.

As an alternative to carrying out this test on the complete equipment or device, the test may be carried out separately on components, sub-assemblies and simulated circuits outside the unit, provided the test results would be representative of the results of testing the complete unit.

2.3.10.2.1 Method of Measurement

- (1) Connect the TE to the test circuit of Figure 2.3(g)
- (2) Connect the voltage source between the telephone connection (1) and the earth grounding connection (2).

- (3) Gradually increase the voltage from zero to the specified level (120 Vrms for TE and 300 Vrms for protective circuit) and maintain this voltage for one minute.
- (4) Monitor and record the current between (1) and (2). Verify that the current does not exceed 10 mA peak at any time.
- (5) Repeat steps (2) to (4) for each applicable connection.

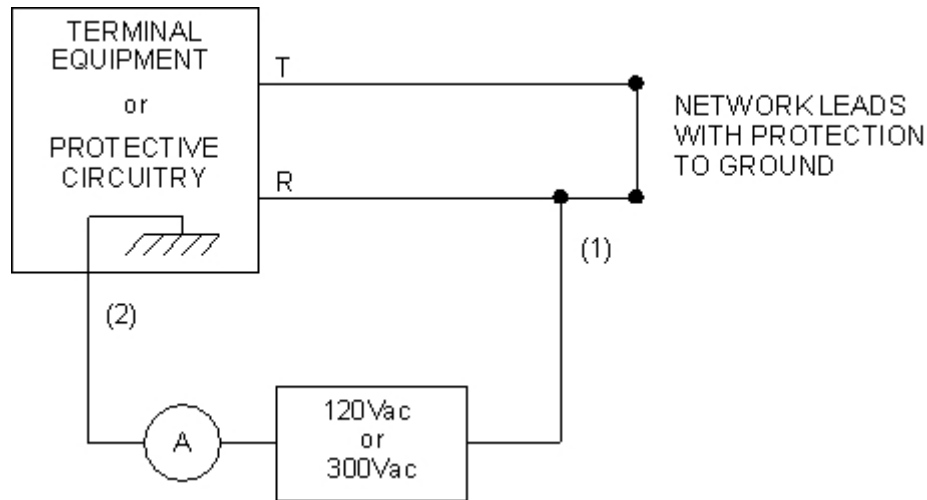

Figure 2.3 (g): Intentional Protective Paths to Ground

2.4 Surge Voltage

Warning - Adequate safety precautions should be observed!

For both Telephone Line Surge Type A and Telephone Line Surge Type B, surges shall be applied as follows:

- (1) With the equipment in states that can effect compliance with the requirements of this specification. If an equipment state cannot be achieved by normal means of power, it may be achieved artificially by appropriate means.
- (2) With equipment leads not being surged (including telephone connections, auxiliary leads and terminals for connection to non-registered equipment), terminated in a manner which occurs in normal use.
- (3) Under reasonably foreseeable disconnection of primary power sources, with primary power cords plugged and unplugged, if so configured.

2.4.1 Telephone Line Surge - Type A

2.4.1.1 Metallic Voltage Surge

Apply two metallic voltage surges (one of each polarity) to equipment between any pair of connections on which lightning surges may occur; this includes (1) tip to ring, (2) tip_1 to ring_1, and (3) for a 4-wire connection which uses simplex pairs for signalling, tip to ring_1 and ring to tip_1.

The surge shall have an open circuit voltage waveshape in accordance with Figure 2.4(a) and a short-circuit current waveshape in accordance with Figure 2.4(b).

The rise time (T_r) and the decay time (T_d) values for these conditions, as well as the peak voltage and the peak short-circuit current values, shall be in accordance with Table 2.4(a).

Table 2.4(a) - Metallic Voltage Surge - Type A

	Open Circuit Voltage	Short Circuit Current
Rise time (T_r)	8 μ s \pm 2 μ s	7.5 μ s \pm 2.5 μ s
Decay time (T_d)	710 μ s \pm 150 μ s	660 μ s \pm 100 μ s
Peak voltage	800 V + 80 V	-
Peak short circuit current	-	100 A + 15 A

2.4.1.2 Method of Measurement (Tip to Ring)

Warning – Initially, all switches in Figure 2.4(c) shall be in position “a”.

Configure the surge generator as outlined in Section 2.4.1.1. Connect the equipment to be surged to the generator terminals (see Figure 2.4(c)).

- (1) Set switch S3 to position “b”. Energize and fire the surge generator.
- (2) Check the terminal equipment operation and record the results.
- (3) Reverse the polarity of the surge and repeat steps (1) and (2).
- (4) Set switch S1 to position “b”. Repeat steps (1) to (3) for all equipment operating states.
- (5) Return all switches to position “a”.

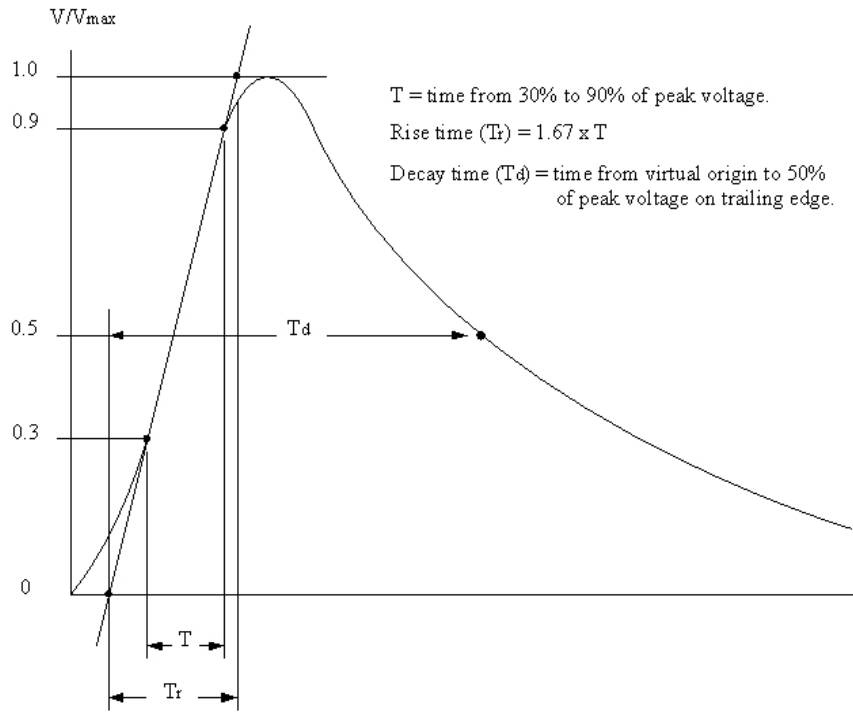

Figure 2.4(a): Open Circuit Voltage Waveshape, $T_r \times T_d$

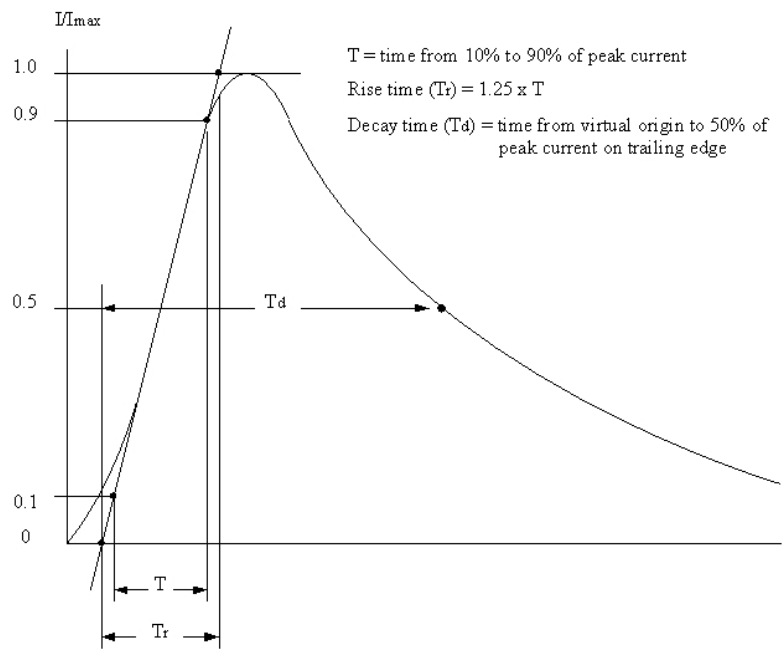

Figure 2.4(b): Open Circuit Current Waveshape, $T_r \times T_d$

2.4.1.3 Longitudinal Voltage Surge

Apply two longitudinal voltage surges (one of each polarity) to equipment from any pair of connections on which lightning surges may occur, including the tip and ring pair and the tip_1 and ring_1 pair, to each of the following:

- (1) Earth grounding connections; and
- (2) All leads intended for connection to non-registered equipment, connected together.

The surge shall have an open circuit voltage waveshape in accordance with Figure 2.4(a) and a short circuit current waveshape in accordance with Figure 2.4(b). The rise time (T_r) and the decay time (T_d) values for these conditions, as well as the peak voltage and the peak short circuit current values, shall be in accordance with Table 2.4(b).

Table 2.4(b) - Longitudinal Voltage Surge - Type A

	Open Circuit Voltage	Short Circuit Current
Rise time (T_r)	8 $\mu s \pm 2 \mu s$	7.5 $\mu s \pm 2.5 \mu s$
Decay time (T_d)	210 $\mu s \pm 50 \mu s$	185 $\mu s \pm 25 \mu s$
Peak voltage	1500 V to 1650	-
Peak short circuit current	-	200 A to 230 A

2.4.1.4 Method of Measurement (Tip and Ring together/and to Ground)

Configure the surge generator as outlined in Section 2.4.1.3. Connect the equipment to be surged to the generator terminals (see Figure 2.4(c)).

- (1) Set switch S3 to position “c” and switch S4 to position “b”. Energize and fire the surge generator.
- (2) Check the terminal equipment operation and record the results.
- (3) Reverse the polarity of the surge and repeat steps (1) and (2).
- (4) Set switch S1 to position “b”. Repeat steps (1) to (3) for all equipment operating states.
- (5) Return all switches to position “a”.

2.4.1.5 Method of Measurement (Tip and Ring Together/and to Other Leads)

Configure the surge generator as outlined in Section 2.4.1.3. Connect the equipment to be surged to the generator terminals. See Figure 2.4(c).

Note: In some cases the AC main power is not connected when surging other equipment leads.

- (1) Set switch S3 to position “d” and switch S4 to position “b”. Energize and fire the surge generator.
- (2) Check the terminal equipment operation and record the results.
- (3) Reverse the polarity of the surge and repeat steps (1) and (2).
- (4) Set switch S1 to position “b”. Repeat steps (1) to (3) for all equipment operating states.
- (5) Return all switches to position “a”.

2.4.1.6 Failure Modes Resulting from the Application of Type “A” Telephone Line Surges

TE and network protection devices shall be evaluated to determine if they can achieve an off-hook state after application of metallic and longitudinal surges. An off-hook condition is achieved by the ability to draw 16 mA or greater from a loop simulator circuit. If an off-hook state cannot be achieved, signal power, billing, and hearing aid compatibility tests need not be conducted.

Regardless of operating state, equipment and circuitry are allowed to be in violation of the transverse balance requirements of Section 3.6 and for limited distance modems TE, the longitudinal signal power requirements of Part VII Section 3.1.1 (3), provided that:

- (1) Such failure results from an intentional, designed failure mode which has the effect of connecting telephone or auxiliary connections with earth grounds; and
- (2) If such a failure-mode state is reached, the equipment is designed in such a manner that it would become substantially and noticeably unusable by the user, or an indication is given (e.g. an alarm) in order that such equipment can be immediately disconnected or repaired.

Note: The objective of this subsection is to allow for safety circuitry to either open circuit, which would cause a permanent on-hook condition, or to short circuit to ground as a result of an energetic lightning surge. Off-hook tests would be trivial if the off-hook state cannot be achieved. A short to ground has the potential for causing interference resulting from longitudinal unbalance, and therefore designs must be adopted that will cause the equipment to either be disconnected or repaired rapidly after such a state is reached, should it occur in service.

2.4.2 Telephone Line Surge - Type B

2.4.2.1 Metallic Voltage Surge

Apply two metallic voltage surges (one of each polarity) to equipment between any pair of connections on which lightning surges may occur, including: (1) tip to ring; (2) tip₁ to ring₁; and (3) for a 4-wire connection that uses simplex pairs of signalling, tip to ring₁ and ring to tip₁.

The surge shall have an open circuit voltage waveshape in accordance with Figure 2.4(a) and a short circuit current waveshape in accordance with Figure 2.4(b). The waveshapes are based on the use of ideal components in Figure 2.4(d) with S2 in position “M”. The rise time (Tr) and the decay time (Td) values for these conditions, as well as the peak voltage and the peak short circuit current values, shall be in accordance with Table 2.4(c).

Table 2.4(c) - Metallic Voltage Surge - Type B

	Open Circuit Voltage	Short Circuit Current
Rise time (Tr)	9 μ s \pm 2.7 μ s	5 μ s \pm 1.5 μ s
Decay time (Td)	720 μ s \pm 144 μ s	320 μ s \pm 64 μ s
Peak voltage	1000 V to 1100 V	-
Peak short circuit current	-	25 A to 27.5 A

2.4.2.2 Method of Measurement (Tip to Ring)

Warning - Initially, all switches in Figure 2.4(c) Shall be in position “a”.

Configure the surge generator as outlined in Section 2.4.2.1. Connect the equipment to be surged to the generator terminals (see Figure 2.4(c)).

- (1) Set switch S3 to position “b”. Energize and fire the surge generator.
- (2) Check the terminal equipment operation and record the results.
- (3) Reverse the polarity of the surge and repeat steps (1) and (2).
- (4) Set switch S1 to position “b”. Repeat steps (1) to (3) for all equipment operating states.
- (5) Return all switches to position “a”.

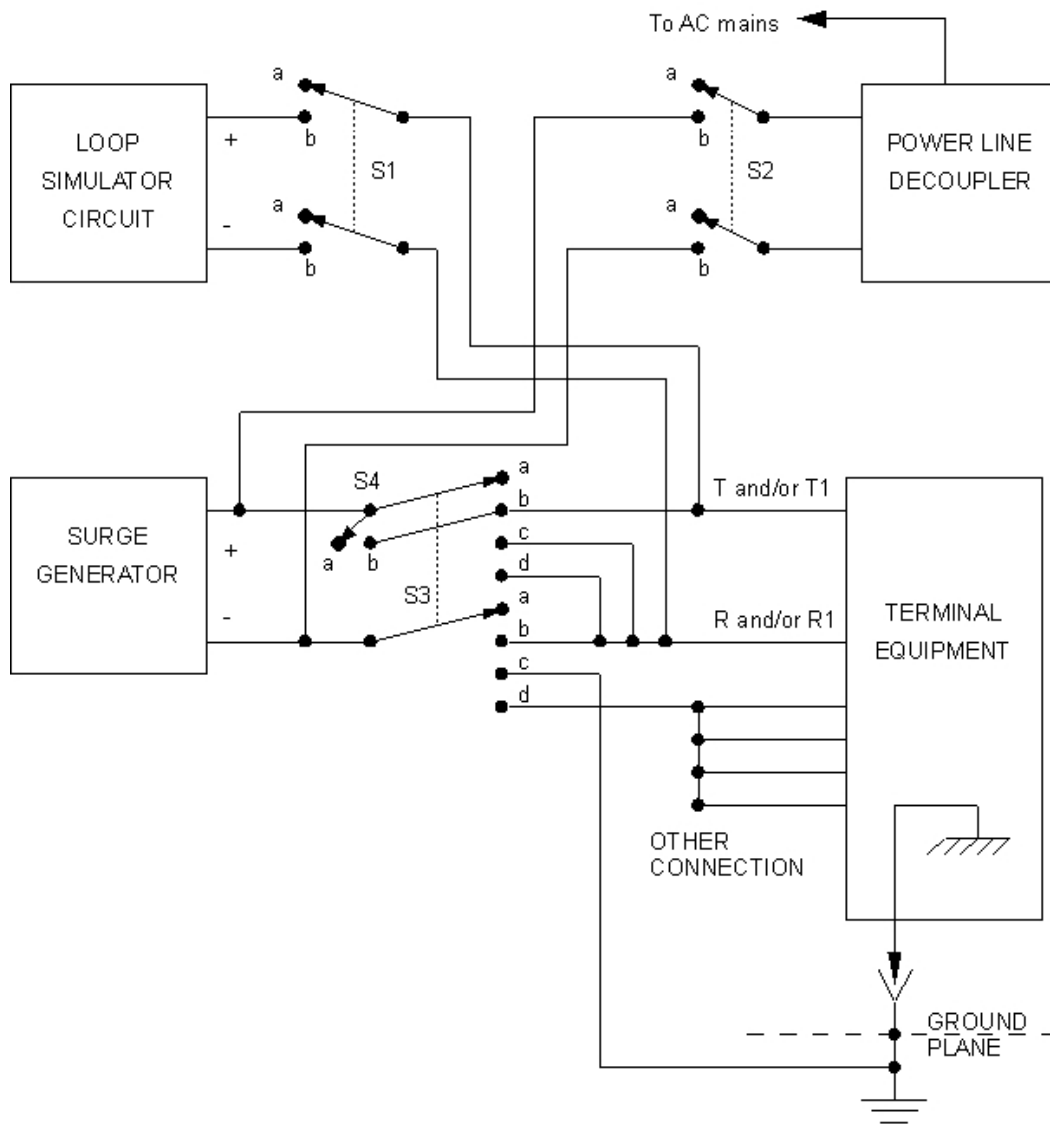

Figure 2.4(c): Surge Voltage Application

Note: When the TE makes provision for an external connection to ground (G), the TE shall be connected to ground. When the TE makes no provision for an external ground, the TE shall be placed on a ground plane that is connected to ground and has overall dimensions at least 50% greater than the corresponding dimensions of the TE. The TE shall be centrally located on the ground plane without any additional connection to ground.

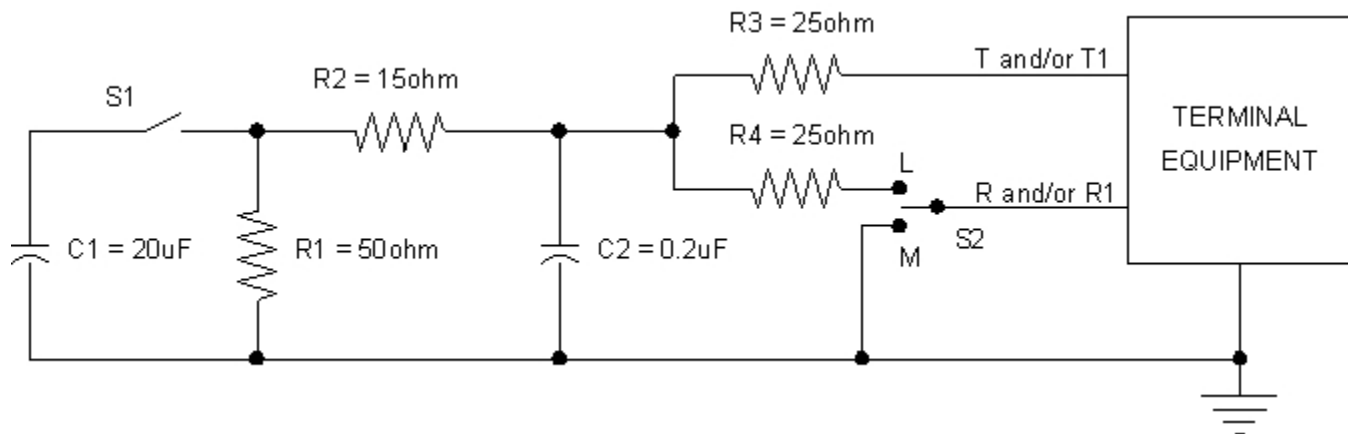

Figure 2.4(d): Simplified Surge Generator

2.4.2.3 Longitudinal Voltage Surge

Apply two longitudinal voltage surges (one of each polarity) to equipment from any pair of connections on which lightning surges may occur, including the tip and ring pair and the tip_1 and ring_1 pair, to each of the following:

- (1) Earth grounding connections, and
- (2) All leads intended for connection to non-registered equipment, connected together.

For each output lead of the surge generator, with the other lead open, the surge shall have an open circuit voltage waveshape in accordance with Figure 2.4(a) and a short circuit current waveshape in accordance with Figure 2.4(b). The waveshapes are based on the use of ideal components in Figure 2.4(d) with S2 in position “L”. The rise time (T_r) and the decay time (T_d) values for these conditions, as well as the peak voltage and the peak short circuit current values, shall be in accordance with Table 2.4(d).

Table 2.4(d) - Longitudinal Voltage Surge - Type B

	Open Circuit Voltage	Short Circuit Current
Rise time (T_r)	$9 \mu s \pm 2.7 \mu s$	$5 \mu s \pm 1.5 \mu s$
Decay time (T_d)	$720 \mu s \pm 144 \mu s$	$320 \mu s \pm 64 \mu s$
Peak voltage	1500 V to 1650 V	-
Peak short circuit current	-	37.5 A to 41.3 A

2.4.2.4 Method of Measurement (Tip and Ring together/and to Ground)

Configure the surge generator as outlined in Section 2.4.2.3. Connect the equipment to be surged to the generator terminals (see Figure 2.4(c)).

- (1) Set switch S3 to position “c” and switch S4 to position “b”. Energize and fire the surge generator.
- (2) Check the terminal equipment operation and record the results.
- (3) Reverse the polarity of the surge and repeat steps (1) and (2).
- (4) Set switch S1 to position “b”. Repeat steps (1) to (3) for all equipment operating states.
- (5) Return all switches to position “a”.

2.4.2.5 Method of Measurement (Tip and Ring together/and to other Leads)

Configure the surge generator as outlined in Section 2.4.2.3. Connect the equipment to be surged to the generator terminals (see Figure 2.4(c)).

Note: In some cases the AC mains power is not connected when surging other equipment leads.

- (1) Set switch S3 to position “d” and switch S4 to position “b”. Energize and fire the surge generator.
- (2) Check the terminal equipment operation and record the results.
- (3) Reverse the polarity of the surge and repeat steps (1) and (2).
- (4) Set switch S1 to position “b”. Repeat steps (1) to (3) for all equipment operating states.
- (5) Return all switches to position “a”.

2.4.2.6 Failure Modes Resulting from the Application of Type “B” Telephone Line Surges

Registered terminal equipment and registered protective circuitry shall withstand the energy of surge type B without causing permanent opening or shorting of the interface circuit and without sustaining damage that will affect compliance with this specification.

2.5 Power Line Surge

Warning - Adequate safety precautions should be observed!

2.5.1 Requirements

Apply six power line surges (three of each polarity) to equipment between the phase and neutral terminals of the AC power line while the equipment is being powered. The surge shall have an open circuit voltage waveshape in accordance with Figure 2.4(a), and a short circuit current waveshape in accordance with Figure 2.4(b). The rise time (T_r) and the decay time (T_d) values for these conditions, as well as the peak voltage and the peak short circuit current values, shall be in accordance with Table 2.5.

Table 2.5 - Power Line Surge

	Open Circuit Voltage	Short Circuit Current
Rise time (T_r)	1.5 μ s \pm 0.5 μ s	1.5 μ s \pm 0.5 μ s
Decay time (T_d)	14.5 μ s \pm 4.5 μ s	14.5 μ s \pm 4.5 μ s
Peak voltage	2500 V to 2750 V	-
Peak short circuit current	-	1000 A to 1250 A

Surges are applied:

- (1) With the equipment in all states that can effect compliance with the requirements of this specification. If an equipment state cannot be achieved by normal means of power, it may be achieved artificially by appropriate means.
- (2) With equipment leads not being surged (including telephone connections, auxiliary leads and terminals for connection to non-registered equipment), terminated in a manner that occurs in normal use.

2.5.2 Method of Measurement

Using the power line decoupler in series with the equipment, configure the generator as outlined in Figure 2.4(c).

- (1) Set switches S3 and S4 to position “a”.
- (2) Set switch S2 to position “b”. Energize and fire the surge generator.
- (3) Check terminal equipment operation and record the results.
- (4) Set switch S1 to position “b”. Reverse the polarity of the surge and repeat steps (1) and (2).
- (5) Repeat steps (1) to (4) for all equipment operating states.
- (6) Return all switches to position “a”.

3.0 Network Protection Requirements

3.1 General

3.1.1 Laboratory Environment

All tests to determine conformity with this specification shall be conducted in a laboratory environment at normal room temperature and humidity.

3.2 For Future Use

Reserved for future use.

3.3 Extraneous AC Energy

3.3.1 Metallic AC Energy

The power delivered into a 2-wire loop simulator circuit or into the transmit and receive pairs of a 4-wire loop simulator or into a 600 ohm termination (where appropriate) in the on-hook state, by loop-start or ground-start equipment, shall not exceed -55 dBm within the frequency band from 200 Hz to 3995 Hz. Network protective circuitry shall also ensure that for any input level up to 10 dB above the overload point, the power to a 2-wire loop simulator circuit or the transmit and receive pairs of a 4-wire loop simulator circuit or into a 600 ohm termination (where appropriate) does not exceed the above limits.

3.3.1.1 Method of Measurement

- (1) Connect the TE to the test circuit as shown in Figure 3.3(a).
- (2) Set the filter to obtain a 200 Hz to 3995 Hz band and arrange the true rms voltmeter in dBm to read power averaged over 3 seconds.
- (3) Verify that the signal level is less than the limit.

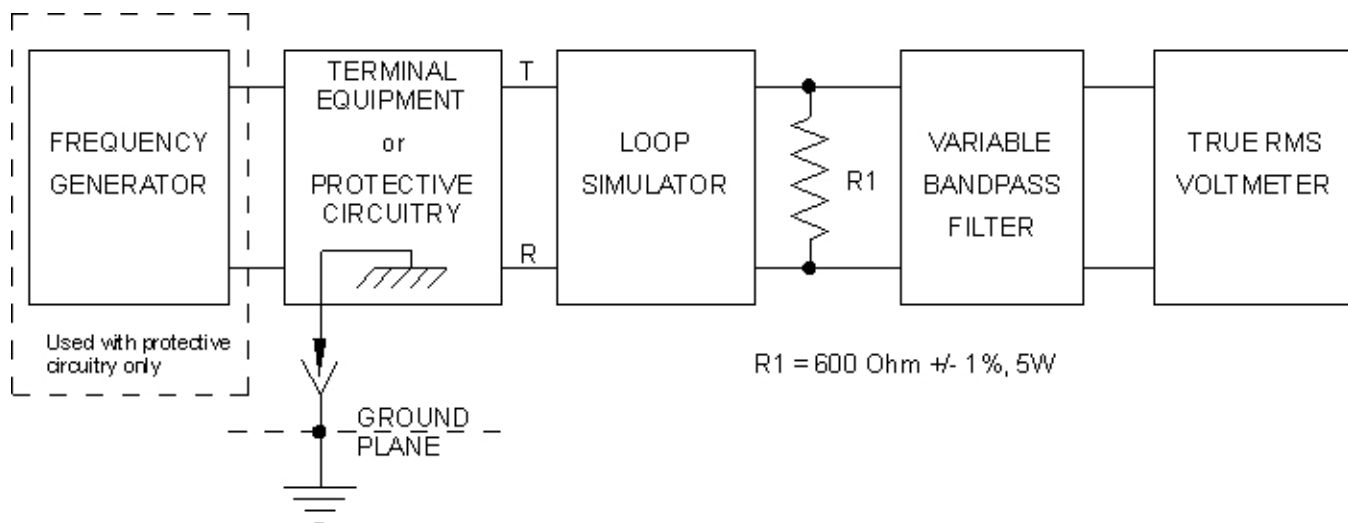

Figure 3.3(a): Metallic AC Signal Measurement

Note: When the TE makes provision for an external connection to ground (G), the TE shall be connected to ground. When the TE makes no provision for an external ground, the TE shall be placed on a ground plane which is connected to ground and has overall dimensions at least 50% greater than the corresponding dimensions of the TE. The TE shall be centrally located on the ground plane without any additional connection to ground.

3.3.2 Longitudinal AC Signals

3.3.2.1 Longitudinal Voltage in the 100 Hz to 4 kHz Range

The weighted rms voltage (see Note in Section 3.3.2.2) averaged over 100 ms that is the result of all of the component longitudinal voltages in the 100 Hz to 4 kHz band after weighting according to the transfer function of $F/4000$, where F is the frequency in hertz, shall not exceed the maximum indicated in Table 3.3(a).

Table 3.3(a)

Frequency range	Maximum rms Voltage	Impedance
100 Hz to 4 kHz	- 30 dBV	500 ohms

3.3.2.2 Longitudinal Voltage in the 4 kHz to 270 kHz Range

The rms value of the longitudinal voltage component in the specified frequency bands shall not exceed the limits given in Table 3.3(b).

Table 3.3(b)

Centre Frequency (f) of 8 kHz Band	Max. Voltage (see Note) in all 8 kHz Bands	Longitudinal Terminating Impedance
8 kHz to 12 kHz	$-(18.4 + 20 \log f)$ dBV	500 ohms
12 kHz to 42 kHz	$(3 - 40 \log f)$ dBV	90 ohms
42 kHz to 266 kHz	-62 dBV	90 ohms

Note: Average magnitudes may be used for signals that have peak-to-rms ratios of 20 dB and less. The rms limitations must be used instead of average values if the peak-to-rms ratio of the interfering signal exceeds this value.

3.3.2.3 Longitudinal Voltage in the 270 kHz to 6 MHz Range

The rms value of the longitudinal voltage components in the frequency range of 270 kHz to 6 MHz shall not exceed -30 dBV. This requirement applies with a longitudinal termination impedance of 90 ohms.

3.3.2.4 Method of Measurement (Longitudinal)

- (1) If the TE has analogue interfaces with through transmission from digital interfaces, connect the TE as shown in Figure 1.5.
- (2) Connect the TE to the test circuit as shown in Figure 3.3(b). Place the TE in the on-hook state.
- (3) For multiple network interfaces, including TE with two or more interfaces (e.g. two-line telephone sets, as well as KTS, PBX etc.), the following applies:
 - (a) One of the interfaces not under test shall be put in the off-hook state.
 - (b) One of the interfaces not under test shall have a ringing signal applied continuously. In the case of TE with two or more network interfaces, one interface not under test shall have a 130 V ringing signal applied continuously during the testing of the other interface(s).
 - (c) One of the interfaces not under test shall be placed on hold (including audio input-on-hold, if provided).
- (4) Set the resistance value to $R1 = R2 = 300$ ohms, and $R3 = 350$ ohms.
- (5) With S1 in position “a”, arrange the true rms voltmeter to read the voltage in dBV in the 100 Hz to 4 kHz band. The weighting network shall have a transfer function of $F/4000$, where F is the frequency in Hz.
- (6) Record the voltmeter reading and add a +3.1 dB correction factor to the measurement value.

- (7) Change the resistance values to $R1 = R2 = 150$ ohms, and $R3 = 425$ ohms.
- (8) Change S1 to position “b” and using either a spectrum analyzer or an rms voltmeter and appropriate filters, measure the signal level in the 4 kHz to 12 kHz band. Add +1.4 dB to the measured value to compensate for the longitudinal termination.
- (9) Change the resistance values to $R1 = R2 = 67.5$ ohms, and $R3 = 56.3$ ohms.
- (10) Using either a spectrum analyzer or an rms voltmeter and filter, set the bandwidth to 8 kHz, sweep the 12 kHz to 270 kHz band and record the results. Add a correction factor of +4 dB to the results to compensate for the difference between the point of measurement and the actual longitudinal impedance (refer to the note below).

Note: If the spectrum analyzer has no 8 kHz bandwidth setting, a 10 kHz bandwidth may be used. However, it will be necessary to apply a -1 dB correction factor, or make additional measurements, or both, to compensate for the wider bandwidth used.

- (11) Compare the results with the allowed limits (refer to the note below).

Note: If a 10 kHz bandwidth is used and a failure condition is noted, it may be necessary to check that reading using a higher resolution if the spectral content had an uneven distribution. The total rms voltage over an 8 kHz band can be calculated by the following expression:

$$V_t = (V_1^2 + V_2^2 + V_3^2 + \dots + V_m^2)^{1/2}$$

where V_t is total rms voltage over any 8 kHz band and $V_1, V_2, V_3, \dots, V_n$ are the spectral components within that band.

If the spectral content of a band is evenly distributed, then the equivalent rms power in an 8 kHz band can be found by subtracting 1 dB from the measured power using a 10 kHz bandwidth.

- (12) With S1 in position “c” and the bandpass filter arranged to pass the 270 kHz to 6 MHz band, measure the peak voltage. Multiply the peak voltage by 0.707 to obtain the rms voltage.
- (13) For registered terminal equipment or protective circuits with provision for through transmission from other equipment, apply one of the following excitation signals (as applicable for the off-hook state):
 - (a) a 1004 Hz signal that results in a power output of -13 dBm delivered into a 600 ohm load at the network interface; or
 - (b) a standard signal or bit stream, simulating normal use of a given type of TE.
- (14) Place the TE in an off-hook state. For loop-start and ground-start trunk interfaces, adjust the DC feed to provide a current equal to the value recorded in Section 3.5.2.2 step (4). Repeat steps (4) to (13).

- (15) Place the TE in an off-hook state. Adjust the DC feed to provide a current of 70 mA (or maximum current, whichever is less). Repeat steps (4) to (12).

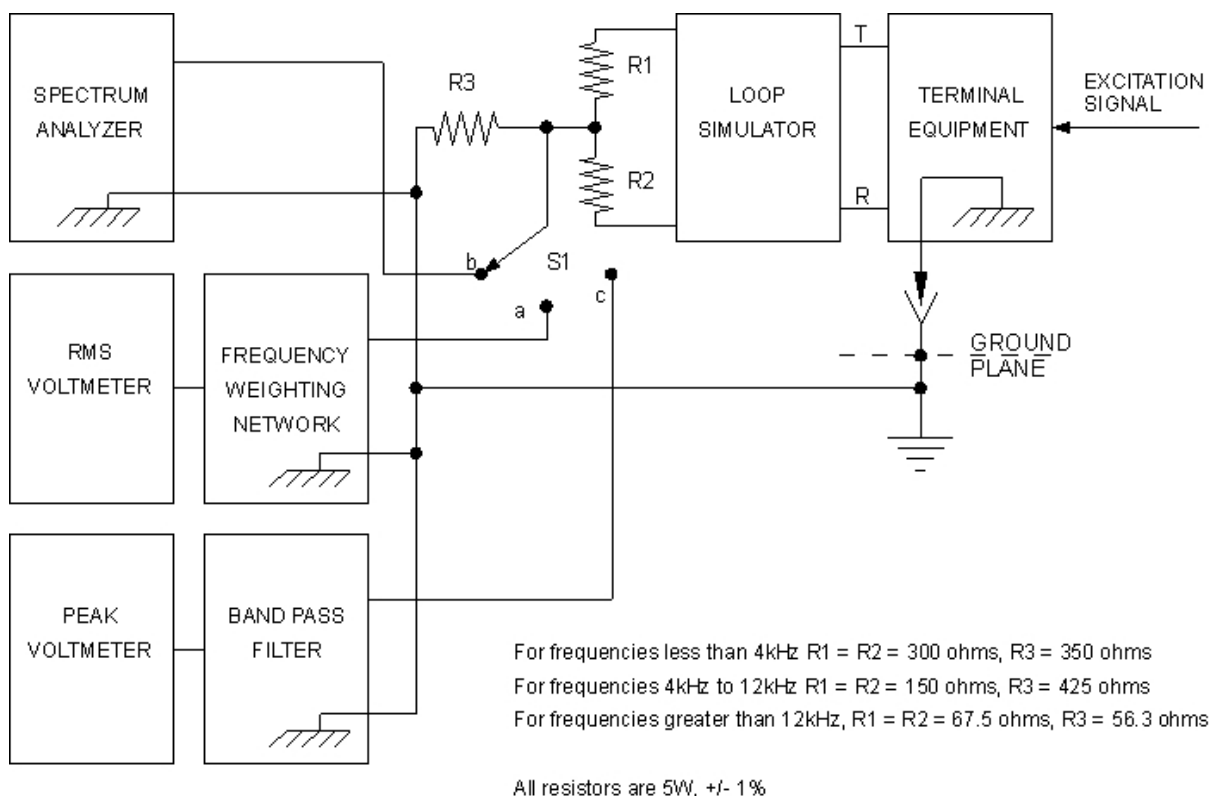

Figure 3.3(b): Longitudinal Signal Power Measurement Method

Note: When the TE makes provision for an external connection to ground (G), the TE shall be connected to ground. When the TE makes no provision for an external ground, the TE shall be placed on a ground plane which is connected to ground and has overall dimensions at least 50% greater than the corresponding dimensions of the TE. The TE shall be centrally located on the ground plane without any additional connection to ground.

3.4 Transmitted Signal Power

3.4.1 In-band Transmitted Signal Power - Metallic

- (1) The power of all signal energy in the frequency band from 200 Hz to 3995 Hz, delivered by the TE or network protection device to the appropriate simulator (other than non-permissive data equipment or data protective circuitry), shall not exceed -9 dBm when averaged over any 3-second interval.
- (2) For 2-wire and 4-wire lossless tie trunk interfaces, the maximum power of other than live voice signals, delivered to a 600 ohm termination, shall not exceed -11 dBm when averaged over any 3-second interval.

- (3) For OPS lines, the maximum power delivered to an OPS line simulator circuit shall not exceed -9 dB with respect to one milliwatt when averaged over any 3-second interval.
- (4) For test equipment, the maximum signal power delivered to a loop simulator circuit shall not exceed 0 dBm when averaged over any 3-second interval.
- (5) For voice band private lines using ringdown or in-band signalling, the maximum power of other than live voice signals delivered to a 600 ohm termination shall not exceed -13 dBm when averaged over any 3-second interval.
- (6) For voice band private lines using in-band signalling in the band 2600 ± 150 Hz, the maximum power delivered to a 600 ohm termination shall not exceed -8 dBm during the signalling mode. The maximum power delivered to a 600 ohm termination in the on-hook steady state supervisory condition shall not exceed -20 dBm. The maximum power of other than live voice signals delivered to a 600 ohm termination during the non-signalling mode and for other in-band systems shall not exceed -13 dBm when averaged over any 3-second interval.

3.4.1.1 Method of Measurement (Voice and Data Circuit TE)

3.4.1.1.1 Voice TE

The voice TE shall be tested as specified in Section 3.4.1.1.3 for any of the following message sources:

- (1) Pre-recorded voice signals as described in Section 3.4.9.1.
- (2) Messages stored permanently within the TE by the manufacturer.
- (3) Messages recorded from the telephone network which can be transmitted back to the network.
- (4) Tone signals originating within the TE.

3.4.1.1.2 Data Circuit TE

The data circuit TE shall be tested as specified in Section 3.4.1.1.3. Where the equipment is designed to operate in response to an external signal (electrical, optical or mechanical), the input signal shall be appropriate for the equipment being tested and shall simulate the worst case that may normally be expected.

3.4.1.1.3 Method of Measurement

- (1) Connect the TE to the test circuit as shown in figures 3.4(a) through 3.4(c).
- (2) Operate the DC feed and ring-up circuit to bring the TE off-hook and apply 70 mA (or maximum current, whichever is less).

- (3) Set the filter cut-off frequencies to achieve a 100 Hz to 4000 Hz bandpass and arrange the voltmeters to read power in dBm averaged over 3 seconds.
- (4) Operate the TE at maximum gain to transmit each of its possible output signals. Where data circuit TE is provided with external or programmable gain control, operate these controls to provide maximum gain for each of its possible signals.
- (5) Facsimile equipment shall be tested in accordance with the IEEE Test Chart 167A-1975 (Figures 7 and 8) to demonstrate compliance with the requirements of Section 3.4.1. In such tests, the facsimile equipment should be conditioned to scan the test pattern repeatedly so that the transmitted signal level measurements can be made.
- (6) Record the maximum power level reading in dBm at minimum and maximum loop currents attainable with the loop simulator, if applicable.
- (7) Repeat steps (4) to (6) for other operating states, if applicable.

Note: When data circuit TE is intended to operate with programming resistors for signal level control, the values of the programmed levels given in Table 3.4(a) shall be verified.

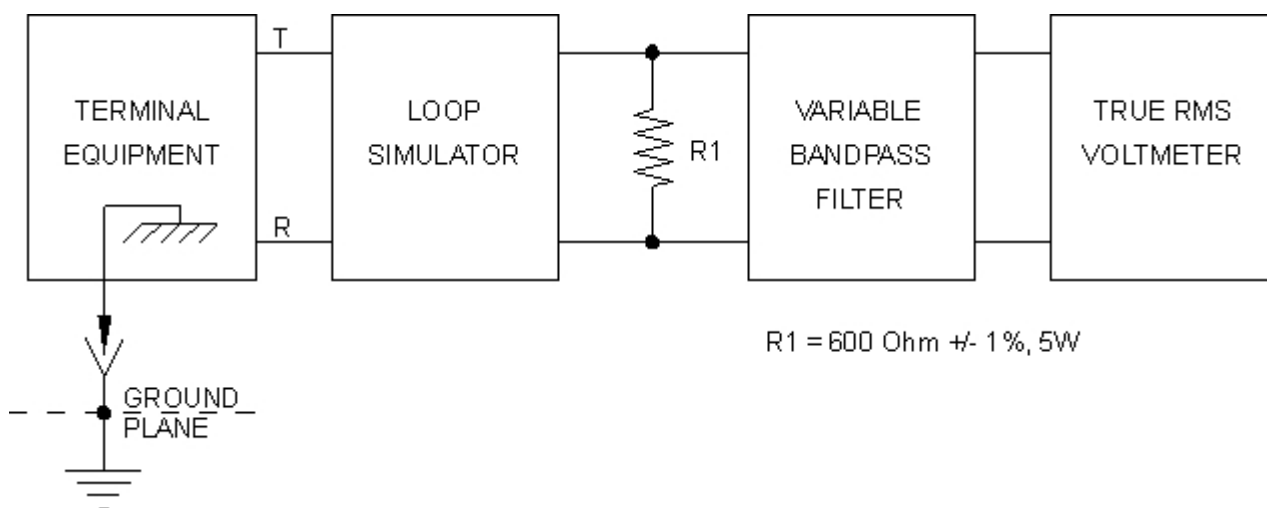

Figure 3.4(a): Transmitted Signal Power Measurement, 2-Wire

- Notes:** (1) When the TE makes provisions for an external connection to ground (G), the TE shall be connected to ground. When the TE makes no provision for an external ground, the TE shall be placed on a ground plane which is connected to ground and has overall dimensions at least 50% greater than the corresponding dimensions of the TE. The TE shall be centrally located on the ground plane without any additional connection to ground.
- (2) Select the appropriate loop simulator for the interface of the terminal equipment.

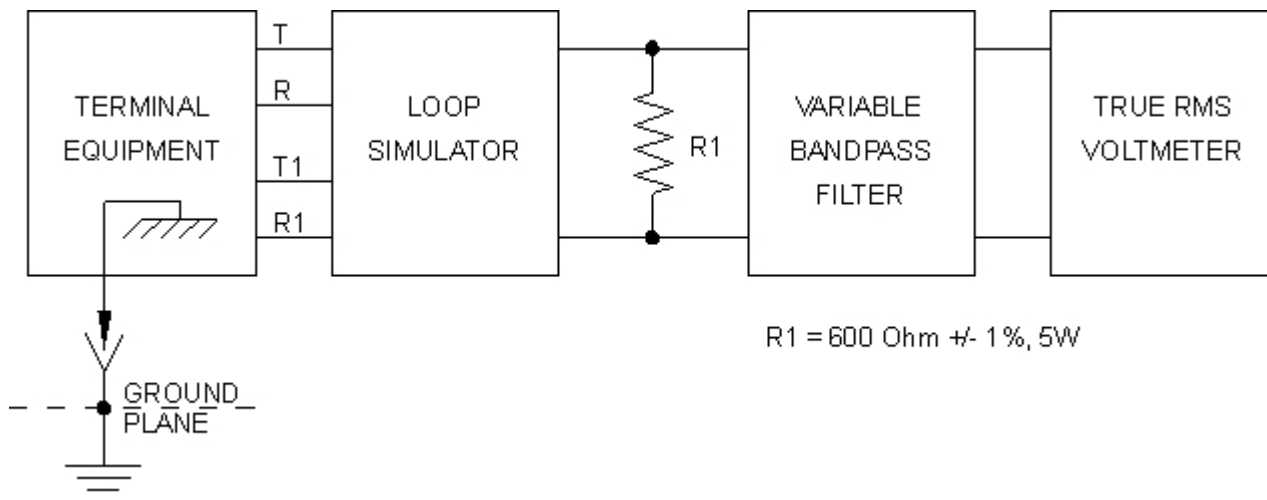
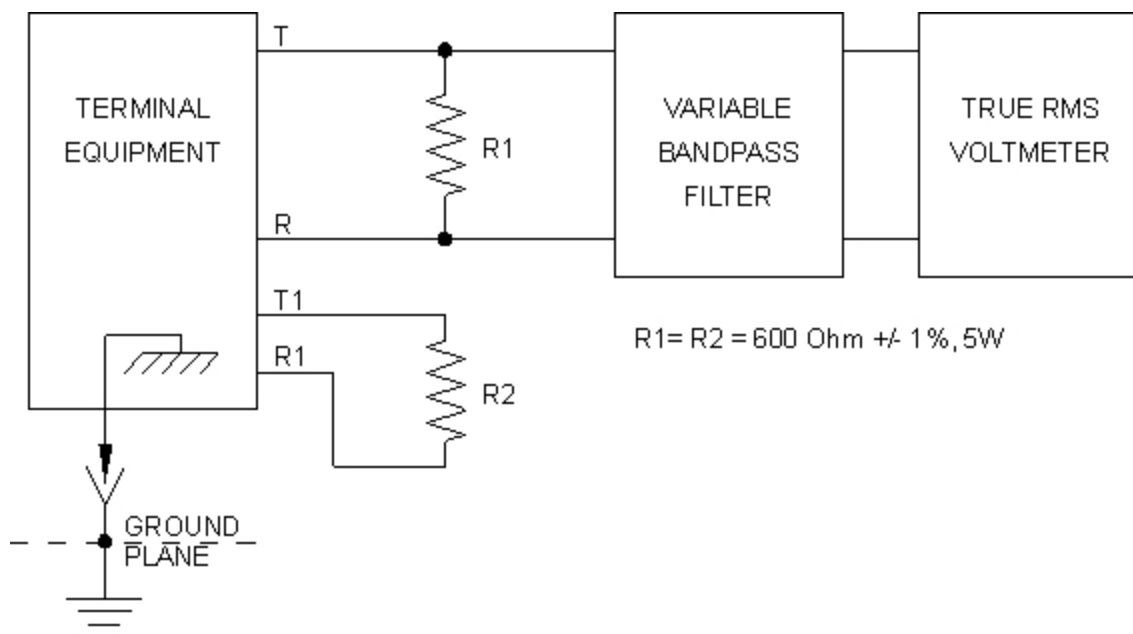

Figure 3.4(b): Transmitted Signal Power Measurement, 4-Wire

- Notes:** (1) When the TE makes provisions for an external connection to ground (G), the TE shall be connected to ground. When the TE makes no provision for an external ground, the TE shall be placed on a ground plane which is connected to ground and has overall dimensions at least 50% greater than the corresponding dimensions of the TE. The TE shall be centrally located on the ground plane without any additional connection to ground.
- (2) Select the appropriate loop simulator for the interface of the terminal equipment.



Note: The figure shown is for a 4-wire interface; for 2-wire interface, the T1 and R1 are not present.

Figure 3.4(c): Transmitted Signal Power Measurement, E&M Tie

- Notes:** (1) When the TE makes provisions for an external connection to ground (G), the TE shall be connected to ground. When the TE makes no provision for an external ground, the TE shall be placed on a ground plane which is connected to ground and has overall dimensions at least 50% greater than the corresponding dimensions of the TE. The TE shall be centrally located on the ground plane without any additional connection to ground.
- (2) Select the appropriate loop simulator for the interface of the terminal equipment.

3.4.2 Limitations on Internal Signal Sources, Primarily Intended for Network Control Signalling, Contained in Voice and Data Equipment

- (1) For all operating conditions of the TE, except tie trunk applications, the maximum power in the frequency band below 3995 Hz delivered to a loop simulator circuit shall not exceed the following when averaged over any 3-second interval:
- (a) 0 dBm when DTMF is used for network control;
 - (b) 0 dBm when DTMF is used for end-to-end signalling via manual entry of a keypad or repertory dialler. The term “repertory dialler” does not accommodate devices capable of generating more than 40 DTMF digits per manual keystroke;
 - (c) -9 dBm in all other cases.
- (2) For tie trunk applications, the maximum power delivered to a 600 ohm termination for TE under all operating conditions shall not exceed -4 dBm over any 3-second interval.

3.4.2.1 Method of Measurement

Refer to the test method given in Section 3.4.1.1.

3.4.3 Requirements for Data Circuit TE

Data circuit TE intended for electrical connection to a network interface shall not transmit rms signal power, in the frequency band from 200 Hz to 3995 Hz that exceeds 0 dBm, when averaged over any 3-second interval. The following additional special case requirements take precedence over the general requirement. Data Circuit TE shall be capable of operation in at least one of the states discussed in (1), (2), or (3) below. The output power level of the data circuit TE shall not be easily alterable by the end user to levels that exceed the signal power limits specified herein.

- (1) Data circuit TE intended to operate with a programming resistor for signal level control, shall not exceed the programmed levels given in Table 3.4(a).
- (2) Data circuit TE intended to be coupled acoustically to the network or intended to connect electrically by means of a voice-type miniature 6-position plug, shall not transmit signals from 200 Hz to 3995 Hz that exceed -9 dBm when averaged over any 3-second interval.

- (3) Data circuit TE intended to operate in the fixed loss loop (FLL) state shall not transmit signal power that exceeds -4 dBm in the frequency band from 200 Hz to 3995 Hz when averaged over any 3-second interval.

Note: Limits on signal power shall be met at the interface for all 2-wire network ports and, where applicable to offered services, both transmit and receive pairs of all 4-wire network ports. Signal power measurements shall be made using terminations as specified in each of the following limitations. The transmit and receive pairs for 4-wire network ports shall be measured with the pair not under test, connected to a termination equivalent to that specified for the pair under test. Through-gain limitations apply only in the direction of transmission toward the network.

Voice band signal power requirements for analogue interfaces apply to the 200 Hz to 3995 Hz band.

Table 3.4(a)

Programming Resistor (Rp)*	Programmed Data Equipment Signal Power Output **
Short circuit	0 dBm
150 ohms	-1 dBm
336 ohms	-2 dBm
569 ohms	-3 dBm
866 ohms	-4 dBm
1240 ohms	-5 dBm
1780 ohms	-6 dBm
2520 ohms	-7 dBm
3610 ohms	-8 dBm
5490 ohms	-9 dBm
9200 ohms	-10 dBm
19800 ohms	-11 dBm
Open circuit	-12 dBm

* Tolerance of Rp is + 1%

** Tolerance of programmed data jack signal power output is + 1 dB. These values shall be averaged over any 3-second interval.

3.4.3.1 Method of Measurement

- (1) Connect the TE to the test circuit as shown in Figure 3.4(d).
- (2) Operate the DC feed and ring-up circuit to bring the TE off-hook and apply 70 mA (or maximum current, whichever is less).
- (3) Set the filter cut-off frequencies to achieve a 100 Hz to 4000 Hz bandpass and arrange the voltmeters to read power in dBm averaged over 3 seconds.
- (4) Operate the TE with a short between the PR and PC port.
- (5) Record the maximum power level reading in dBm at minimum and maximum loop currents attainable with the loop simulator, if applicable.
- (6) Repeat step (5) with all other programmable resistor (R_p) values in table 3.4(a), if applicable.

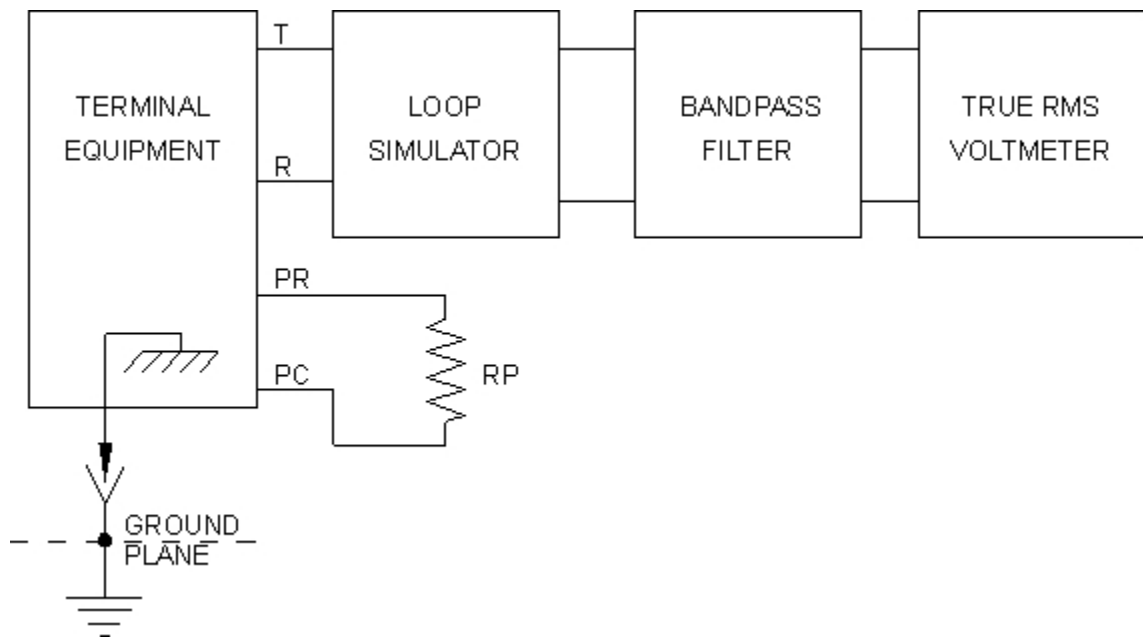

Figure 3.4(d): Transmitted Signal Power Measurement with Programming Resistor

Note: For programmed data equipment, measurements should be made with the value of the programming resistor (R_p) set for each of the following values: short circuit, 150 ohms, 336 ohms, 569 ohms, 866 ohms, 1240 ohms, 1780 ohms, 2520 ohms, 3610 ohms, 5490 ohms, 9200 ohms, 19800 ohms, and open circuit.

3.4.4 Through Transmission

3.4.4.1 Requirements

- (1) The loss in any through transmission path of TE at any frequency in the 600 Hz to 4000 Hz band shall not exceed by more than 3 dB the loss at any frequency in the 3995 Hz to 4005 Hz band when measured into an appropriate simulator circuit from a source that appears as 600 ohms across tip and ring.
- (2) For single-port and multi-port TE and network protection devices with provision for through transmission from other TE, excluding data equipment:
 - (a) Where through transmission equipment provides a DC electrical signal to equipment connected therewith (e.g. for powering of electro-acoustic transducers), the DC conditions shall be provided that meet the requirement below, unless the combination of the through transmission equipment and equipment connected therewith is registered as a combination that conforms to sections 3.4.1 and 3.4.2.
 - (1) The open circuit voltage shall not exceed 56.5V.
 - (2) The short circuit current shall not exceed 140 mA.
 - (3) The current provided into a 430 ohm resistor, or the maximum external resistive load supported by the equipment, if greater, shall be greater than 20mA.
 - (b) Through transmission equipment to which remotely connected data TE may be connected shall not be equipped with or connected to either a universal or programmed data jack used in data configurations.
- (3) For single-port and multi-port TE and network protection devices, with provision for through transmission from ports to other equipment which is separately registered for the public switched network or ports to other network interfaces:
 - (a) TE and network protection devices shall have no adjustments which will allow net amplification to occur in either direction of transmission in the through transmission path within the 200 Hz to 3995 Hz band which will exceed the allowable net amplification as specified in Table 3.4(b).
 - (b) The insertion loss in through connection paths for any frequency in the 800 Hz to 2450 Hz band shall not exceed the loss at any frequency in the 2450 Hz to 2750 Hz band by more than 1 dB (maximum loss in the 800 Hz to 2450 Hz band minus minimum loss in the 2450 Hz to 2750 Hz band plus 1 dB).

Table 3.4(b) - Allowable Net Amplification Between Ports

To	Tie Trunk Type Ports			Integrated Services Trunk Ports	Off-premises Station Ports (2-wire)	Analogue Public Switched Network Ports (2-wire)	Subrate 1.544 Mbps Digital PBX-CO Trunk Ports (4-wire)
	Lossless (2/4-wire)	Subrate 1.544 Mbps Satellite (4-wire)	Subrate 1.544 Mbps Tandem (4-wire)				
Lossless Tie Trunk Port (2/4-wire)	0 dB	2 dB	2 dB	2 dB	2 dB	-	-
Subrate 1.544 Mbps Satellite Tie Trunk Port (4-wire)	1 dB	-	3 dB	3 dB	3 dB	-	-
Subrate 1.544 Mbps Tandem Tie Trunk Port (4-wire)	-2 dB	0 dB	0 dB	0 dB	0 dB	-	-
Integrated Services Trunk Ports	-2 dB	0 dB	0 dB	0 dB	0 dB	-	-
Registered Digital TE	-2 dB	0 dB	0 dB	0 dB	0 dB	0 dB	0 dB
On-premises Station Port with Registered TE (see Note 2)	-2 dB	0 dB	0 dB	0 dB	0 dB	0 dB	0 dB
Off-premises Station Port (2-wire)	2 dB	4 dB	4 dB	4 dB	4 dB	4 dB	4 dB
Analogue Public Switched Network Ports (2-wire)	-	-	-	-	3 dB	3 dB	-
Subrate 1.544 Mbps Digital PBX-CO Trunk Ports (4-wire)	-	-	-	-	0 dB	-	-

Notes:

- (1) The source impedance for all measurements shall be 600 ohms. All ports shall be terminated in appropriate loop or private line channel simulator circuits or 600 ohm terminations.
- (2) These ports are for 2-wire on-premises station ports to separately registered TE.

- (3) These through gain limitations are applicable to multi-port systems where channels are not derived by time or frequency compression methods. TE employing such compression techniques shall ensure that equivalent compensation for through gain parameters is evaluated and included in the test report.
- (4) TE and network protection devices may have net amplification exceeding the limitations of this subsection provided that, for each network interface type to be connected, the absolute signal power levels specified in this section are not exceeded.
- (5) The indicated gain is in the direction that results when moving from the horizontal entry toward the vertical entry.
- (6) TE or network protection devices with the capability for through transmission from voice band private line channels or voice band metallic channels to other telephone network interfaces shall ensure, for each telephone network interface type to be connected, that the absolute signal power levels specified in this section are not exceeded.
- (7) TE or network protection devices with the capability for through transmission from voice band private line channels or voice band metallic private line channels to other telephone network interfaces shall ensure, for each telephone network interface type to be connected, that signals with energy in the 2450 Hz to 2750 Hz band are not through transmitted unless there is at least an equal amount of energy in the 800 Hz to 2450 Hz band within 20 milliseconds of application of signal.

3.4.4.2 Method of Measurement

When the interface impedances are not evident from the information provided by the applicant, the testing facility will contact the applicant and request that this information be provided so that appropriate correction factors can be calculated for the through transmission loss measurements.

- (1) Connect the TE to the test circuit shown in Figure 3.4(e).
- (2) Set switch S1 and switch S2 to position “a”. Adjust the filter to pass the band of frequencies below 3995 Hz.

Note: If the device under test is band limited, the appropriate filter adjustment shall be made.

- (3) Establish a through transmission path in the direction of the network interface under test.
- (4) Set the output level of the white noise generator so that the voltmeter indicates -11 dBV at the network interface. This level is to be maintained for all tests.
- (5) Set switch S1 to position “b” and measure the signal present at the input side of the TE.
- (6) Calculate the gain of the through transmission path from the output level set in step (4) and the input level measured in step (5).

- (7) Set the filter to pass the 600 Hz to 3995 Hz band of frequencies. Measure the level of signal present at the input side of the TE.
- (8) Set switch S1 to position “a” and measure the level of the signal present at the output side of the TE. Calculate the gain in the 600 Hz to 3995 Hz band.
- (9) Set switch S1 and S2 to position “b”, set the oscillator frequency to 4 kHz, and adjust the output of the oscillator to match the level measured in step (7).
- (10) Set switch S1 to position “a” and measure the signal level present at the network interface. Calculate the gain at 4 kHz.
- (11) Use the results from steps (8) and (10) determine the difference in gain between the two bands.
- (12) Substitute the voltmeter for the spectrum analyzer in Figure 3.4(e).
- (13) Set S2 to position “a” and switch S1 to position “b”. Use the spectrum analyzer to measure the signal in the 800 Hz to 2450 Hz band, as described in Section 3.5.3. Measure and record the signal present at the input side of the TE.
- (14) Set switch S1 to position “a”. Measure and record the signal present at the output side of the TE. Calculate the gain in the 800 Hz to 2450 Hz band.
- (15) Set switch S1 to position “b”. Measure and record the signal in the 2450 Hz to 2750 Hz band at the input side of the TE.
- (16) Set switch S1 to position “a”. Measure and record the signal level present at the output side of the TE. Calculate the gain in the 2450 Hz to 2750 Hz band.
- (17) Use the results from steps (14) and (16) to determine the difference in gain between the two frequency bands.
- (18) Repeat steps (1) to (17) for any through transmission path network interface. Through transmission paths that can provide connections between two network interfaces shall be evaluated in both directions.

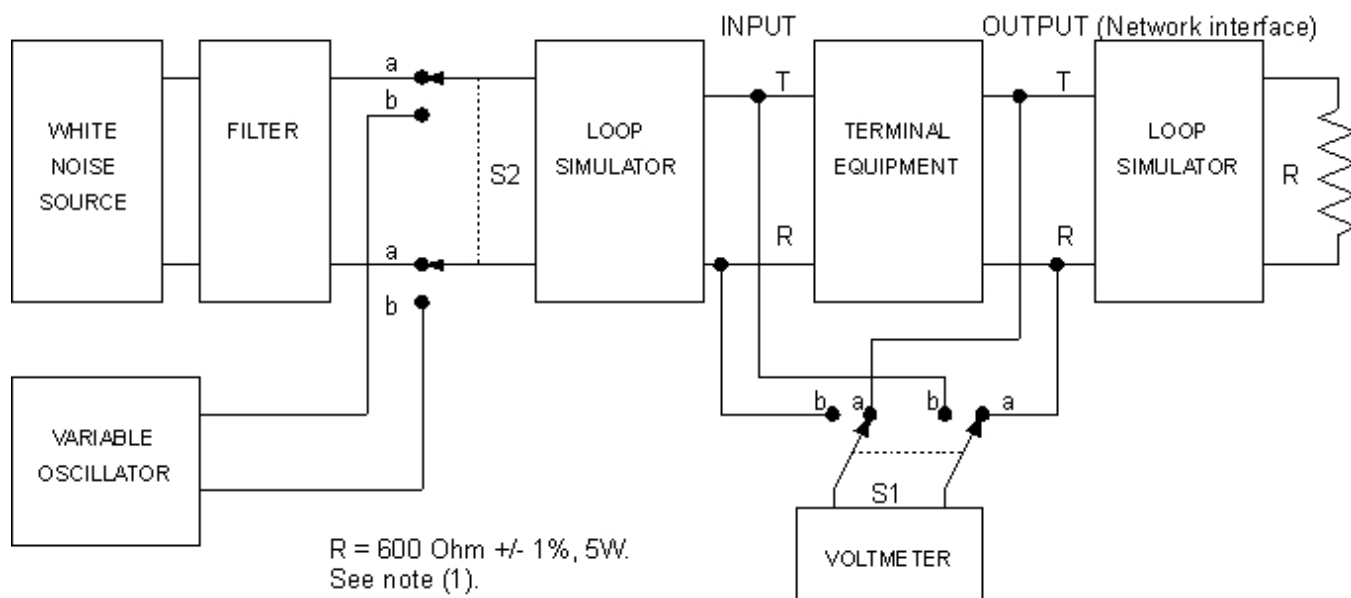

Figure 3.4(e): Measurement of Through Path Transmission

Notes:

- (1) The alternative termination network of Figure 4. 6 may be substituted for R during the off-hook measurements for the requirements of Section 3.4.4.
- (2) Battery must be switched out of the feed when testing a station or reverse-battery trunk interface.

3.4.4.3 Method of Measurement (DC Conditions)

- (1) Connect the TE to the test circuit as shown in Figure 3.4(f).
- (2) With S1 and S2 in position “a” measures the open circuit voltage.
- (3) With S1 and S2 in position “b” measures the short circuit current.
- (4) Switch S2 to position “c” and measure the current through the 430 ohm resistor.
- (5) If the TE supports a greater resistive load, adjust the resistor to this value and measure the current.

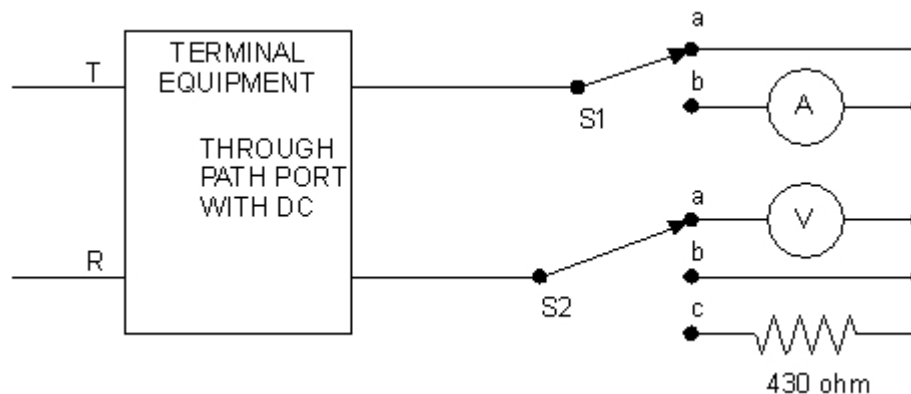

Figure 3.4 (f): Measurement of Through Path DC Conditions

3.4.5 DC Conditions to Off-premises Stations (OPS) Lines

Registered terminal equipment and registered protective circuitry shall provide the following range of DC conditions to off-premises station (OPS) lines:

- (1) DC voltages applied to the OPS interface for supervisory purposes and during network control signalling shall meet the limits specified in Section 2.3.4.
- (2) DC voltages applied to the OPS interface during the talking state shall meet the following requirements:
 - (a) The maximum open circuit voltage across the tip (T (OPS)) and ring (R (OPS)) leads for all classes shall not exceed 56.5 V.
 - (b) Except for Class A OPS interfaces, the maximum DC current into a short circuit across tip (T(OPS)) and ring (R(OPS)) leads shall not exceed 140 mA.
 - (c) Except for Class A OPS interfaces, the DC current into the OPS line simulator circuit shall be at least 20 mA for the following conditions (see Figure 4.5):

Table 3.4(c)

Condition	R + RL	
	Class B	Class C
1	600	1300
2	1800	2500

3.4.5.1 Method of Measurement

- (1) Connect the TE to test circuit as in Figure 3.4(g).
- (2) Place the TE into the talking state.

- (3) For Class B and Class C OPS interfaces, close switch S1, and measure the short circuit current between T(OPS) and R(OPS).
- (4) Open switch S1.
- (5) Place the OPS simulator into condition “1”.
- (6) Adjust R as given in Table 3.4(c) for Class B and Class C OPS interfaces.
- (7) Record the current flowing in the circuit.
- (8) Place the simulator circuit into condition “2” and repeat steps (6) and (7).

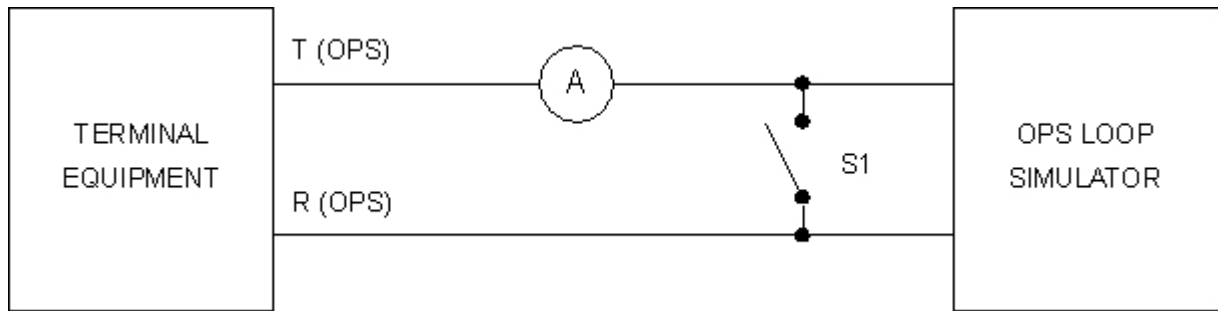

Figure 3.4(g): OPS DC Conditions

Note: Loop current is measured with a current meter in series with an OPS loop simulator. Refer to Figure 4.5.

3.4.6 Out-of-band Transmitted Signal Power - Metallic

- (1) For all operating conditions of TE and network protective circuitry which incorporate signal sources other than sources intended for network control signalling, the maximum power delivered by such sources in the 3995 Hz to 4005 Hz band to an appropriate simulator circuit shall be 18 dB below the maximum permitted power specified in sections 3.4.1 to 3.4.4 of this section for the voice band.

(2) 4 kHz to 270 kHz

The signal level within the specified frequency band, when averaged over 100 ms between tip and ring of the TE, shall not exceed the limits given in Table 3.4(d).

Table 3.4(d)

Centre Frequency (f) of 8 kHz Band	Maximum Voltage in all 8 kHz Bands	Metallic Terminating Impedance
8 kHz to 12 kHz	- (6.4 + 12.6 log f) dBV	300 ohms
12 kHz to 90 kHz	(23 - 40 log f) dBV	135 ohms
90 kHz to 266 kHz	-55 dBV	135 ohms

(3) 270 kHz to 30 MHz

The rms value of the metallic voltage components in the frequency range of 270 kHz to 30 MHz shall, averaged over 2 μs, not exceed -15 dBV. This limitation applies with a metallic termination having an impedance of 135 ohms.

3.4.6.1 Method of Measurement (Metallic)

- (1) If the TE has analogue interfaces with through transmission from digital interfaces, connect the TE as shown in Figure 1.5.
- (2) Connect the TE to the test setup as shown in Figure 3.4(h). Place the TE in the on-hook state.
- (3) If the TE has multiple network interfaces (e.g. two-line telephone sets as well as KTS, PBX, etc.) proceed as follows:
 - (a) One of the interfaces not under test shall be put in the off-hook state.
 - (b) One of the interfaces not under test shall have a ringing signal applied continuously. In the case of TE with two or more network interfaces, one interface not under test shall have a 130 V ringing signal applied continuously during the testing of the other interface(s).
 - (c) One of the interfaces not under test shall be placed on hold (including audio input-on-hold, if provided).
- (4) With R1 equal to 600 ohms and using either a spectrum analyzer or an rms voltmeter with a bandpass filter, set switch S1 in position “a” and measure the signal level (dBm) in the 3995 Hz to 4005 Hz band. Ensure that the results are 20 dB lower than the value measured in sections 3.4.1 to 3.4.4.

- (5) With R1 equal to 300 ohms and using either a spectrum analyzer or an rms voltmeter with a bandpass filter, set switch S1 in position “a” and measure the signal level (dBV) in the 4 kHz to 12 kHz band.
- (6) Replace R1 with a 135 ohm resistor. Using a spectrum analyzer with the bandwidth set to 8 kHz, sweep the frequency band from 12 kHz to 270 kHz and record the results.

Note: If the spectrum analyzer available does not have an 8 kHz bandwidth setting, a 10 kHz bandwidth may be used. Apply a -1 dB correction factor or make additional measurements, or both, to compensate for the wider bandwidth used.

- (7) Measure the metallic signal power in the frequency range of 270 kHz to 30 MHz using a wideband power meter in conjunction with a 270 kHz to 30 MHz bandpass filter. Alternatively, use a spectrum analyzer with band power markers set for 270 kHz to 30 MHz and record the worst-case result.

Note: If a 10 kHz bandwidth is used and a failure condition is noted, it may be necessary to check the reading using a higher resolution if the spectral content had an uneven distribution. The total rms voltage over an 8 kHz band can be calculated by means of the following formula:

$$V_t = (V_1^2 + V_2^2 + V_3^2 + \dots + V_m^2)^{1/2}$$

where V_t is total rms voltage over any 8 kHz band and $V_1, V_2, V_3, \dots, V_m$ are the spectral components within that band.

If the spectral content of a band is evenly distributed, the equivalent rms power in an 8 kHz band can be found by subtracting 1 dB from the measured power using a 10 kHz bandwidth.

- (8) Compare the results with the allowed limits.
- (9) Place the TE in the off-hook state. For loop-start and ground-start trunk interfaces, adjust the DC feed to obtain both a minimum and maximum loop current. Repeat steps (3) to (8) for each current setting.

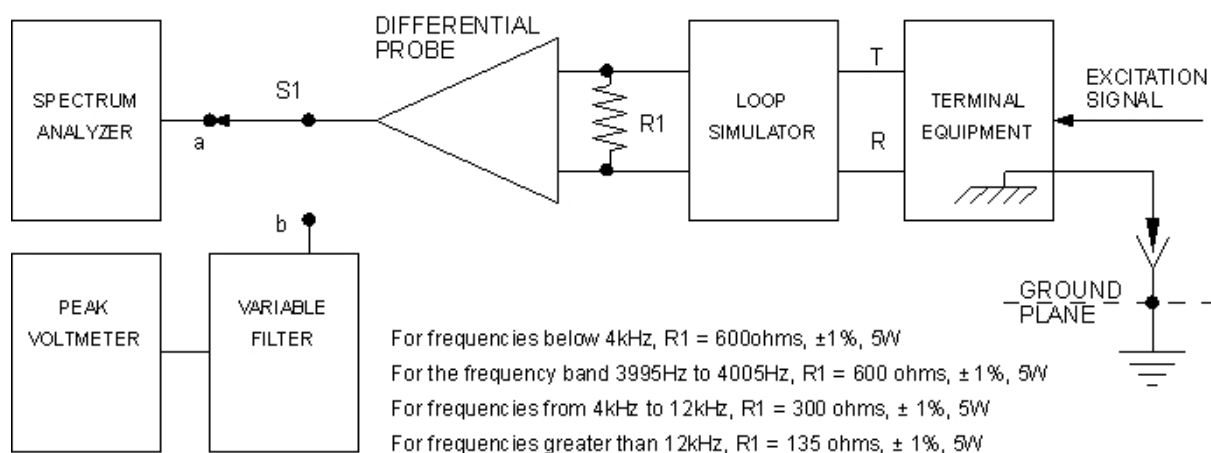

Figure 3.4(h): Out-of-band Signal Level Measurement

- Notes:** (1) When the TE makes provision for an external connection to ground (G), the TE shall be connected to ground. When the TE makes no provision for an external ground, the TE shall be placed on a ground plane which is connected to ground and has overall dimensions at least 50% greater than the corresponding dimensions of the TE. The TE shall be centrally located on the ground plane without any additional connection to ground. The differential probe is used to isolate the ground from the measurement.
- (2) The roll-off used in bandpass filters of the CODECs in digital TEs causes the signal power in the 3995 Hz to 4005 Hz to be at least 30 dB down from the reference values at 10000 Hz. Hence this requirement does not apply to digital EUT.

3.4.7 For Future Use

3.4.8 Audio Signal Limiting

3.4.8.1 Requirements

- (1) For network protection devices with signal limiting from an internal source, the requirements of sections 3.4.1(1), 3.4.1(2) and 3.4.1(3), as appropriate, shall be met with the source activated.
- (2) For network protection devices with signal limiting from an external source, the overload point shall be determined and the requirements of sections 3.4.1(1), 3.4.1(2) and 3.4.1(3), as appropriate, shall be met with an input level 10 dB above the overload point but not exceeding 70 V rms.
- (3) The requirements of Section 3.4.6 shall be met at the measurement levels determined by overload point and, where an external source is provided, over the input frequency range of 200 Hz to 20 kHz.
- (4) Where an audio output is provided from an external source, the requirements of sections 3.4.4 and 3.5.3 shall be met for this through transmission path.
- (5) The protective circuitry shall have no user-accessible adjustments that will allow these parameters to be exceeded.

3.4.8.2 Method of Determining the Overload Point

- (1) Connect a sine wave input of 1004 Hz to the audio input (audio-input or on-hold port) and monitor the input and output (network interface) levels.
- (2) Set the signal at a level at which through transmission gain is not significantly affected by moderate changes in level.
- (3) Increase the input level until the through transmission gain has dropped by 0.4 dB or until 70 V rms is reached, whichever input level is the lesser. The input level at which this occurs is defined as the overload point.

3.4.9 Method Used to Generate Audio Signals

3.4.9.1 Method 1 - Pre-recorded Voice Signals

An acoustic signal generated by the method shown in Figure 3.4(e) at a sound pressure level of 0 dB Pa (94 dB SPL) FLAT weighted, shall be recorded on the announcement recording tape using the microphone supplied with the answering device or shall be connected directly to the network by means of an acoustic input device. The loudspeaker and sound level meter microphone in the test circuit in Figure 3.4(e) must be located at least 1 m from any reflecting surface, such as tables, workbenches, wall, etc. The circuit shall be calibrated as follows:

- (1) Disable OSC. No. 4 (0% modulation).
- (2) Disable OSC. No. 2 and OSC. No. 3.
- (3) Enable OSC. No. 1 and adjust its output for a Sound Level Meter reading between -9 and -4 dB Pa (85 and 90 dB SPL) FLAT weighted.
- (4) Disable OSC. No. 1. Enable OSC. No. 2 and adjust OSC. No. 2 output to produce the same reading on the Sound Level Meter as was noted in step (3) for OSC. No.1.
- (5) Disable OSC. No. 2. Enable OSC. No.3 and adjust OSC. No.3 output to produce the same reading on the Sound Level Meter as was noted in step (3) for OSC. No. 1.
- (6) Enable OSC. No. 1, OSC. No. 2, OSC. No. 3 and adjust OSC. No. 4 to obtain approximately 50% amplitude modulation.
- (7) Adjust the variable attenuator for a Sound Level Meter reading of 0 dB Pa (94 dB SPL FLAT). With the acoustic field so adjusted, the Sound Level Meter microphone is replaced by the microphone (or other acoustic input device) of the TE. Recording of transmission is then performed.

For TE with capabilities for recording messages from the network which can be transmitted back to the network, the reference testing signal shall be obtained as follows. After calibrating the test circuit shown in Figure 3.4(i) by the method given in steps (1) to (7), remove the speaker from the circuit and use the connected rms level meter to measure the output signal, -12 dBV (-14.2 dBm, 600 ohms), at point A.

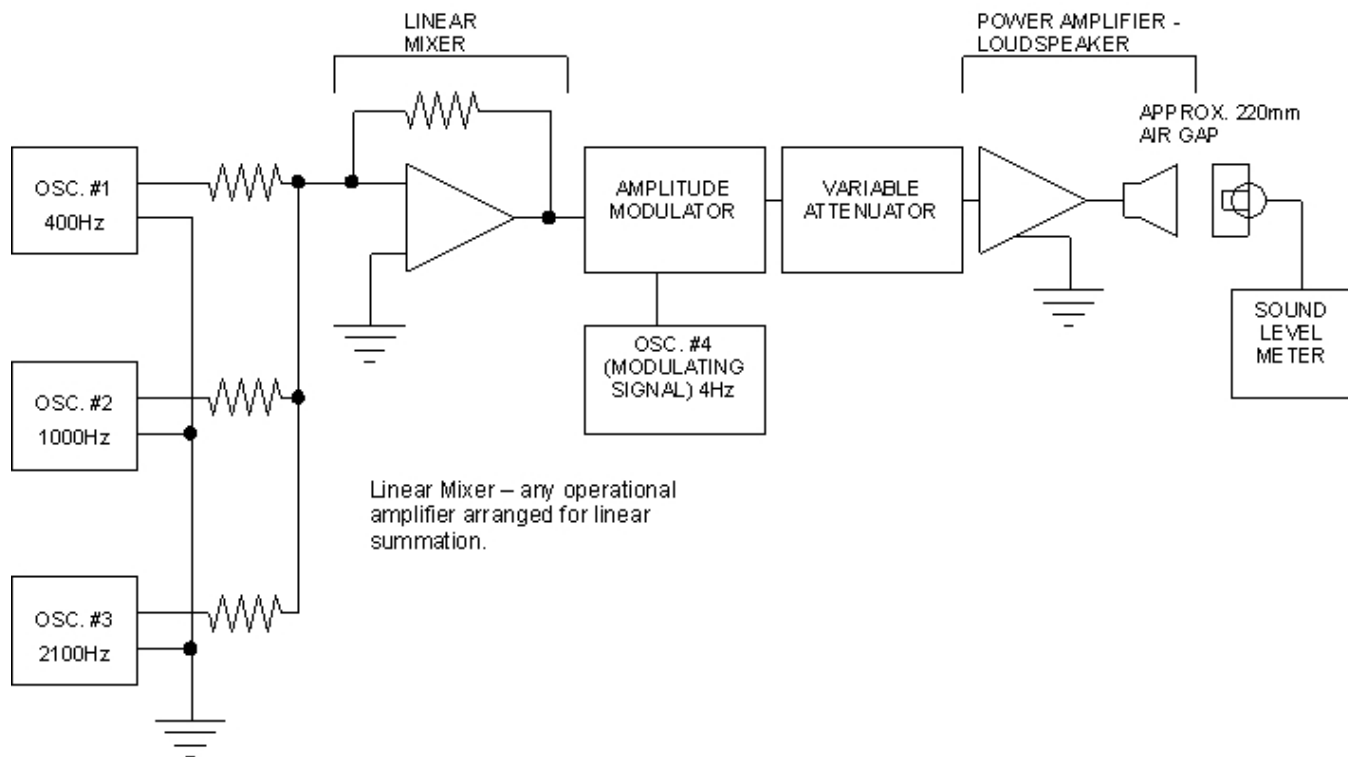

Figure 3.4(i): Circuit Used for Generating Audio Signals

3.5 Billing Protection

3.5.1 Call Duration

3.5.1.1 Requirements

Registered data terminal equipment and registered protective circuitry shall comply with the following requirements when answering an incoming call, except in the off-hook state during which the signals are transmitted and/or received as electro-acoustic transducers only.

Note: The preceding paragraph is applicable to registered terminal equipment and registered protective circuitry employed with digital services where such digital services are interconnected with the analogue telephone network.

- (1) Registered protective circuitry connected to associated data equipment will meet the following signal power limitations for at least the first 2 seconds after the off-hook condition is presented to the telephone network in response to an incoming call:
 - (a) The total power of signals that appear at the protective circuitry/telephone network interface for delivery to the telephone network, when measured with the appropriate loop simulator circuit or a 600 ohm termination, will be limited to -55 dBm within the voice band; and

- (b) Signals that appear at the protective circuitry-associated data equipment interface for delivery to associated data equipment shall be limited as follows: for any received signal power up to 0 dBm (within the voice band), the power of signals delivered to associated data equipment shall be no greater than the signal power that would be delivered as a result of received signal power of -55 dBm.
- (2) Registered terminal equipment for data applications shall ensure that, when an incoming telephone call is answered, the answering terminal equipment prevents both transmission and reception of data for at least the first two seconds after the answering terminal equipment transfers to the off-hook condition. For the purpose of this requirement, a fixed sequence of signals that is transmitted (and originated within) and/or received by the approved terminal equipment each time it answers an incoming call shall not be considered data, provided that such signals are for one or more of the following purposes:
- (a) Disabling echo control devices;
 - (b) Adjusting automatic equalizers and gain control;
 - (c) Establishing synchronization; or
 - (d) Signalling the presence and, if required, the mode of operation of the data terminal at the remote end of a connection.

3.5.1.2 Method of Measurement

- (1) For protective circuitry for data equipment that has access to the public switched network:
- (a) Connect the TE to the test circuit of Figure 3.5(a).
 - (b) Set the frequency generator for 1000 Hz and 0 dBm.
 - (c) Set the oscilloscope to trigger on transition from the on-hook to the off-hook state of the TE.
 - (d) Apply the ringing signal to the terminal equipment.
 - (e) Record the signal level that is transmitted to the network after the TE goes off-hook. Check for compliance during the first 2 seconds after going off-hook.
 - (f) Connect the TE to the test circuit of Figure 3.5(b).
 - (g) Set the frequency generator to 1000 Hz and -55 dBm. The specified -55 dBm limit for transmission is considered to be equivalent to no transmission and applies in both transmit and receive conditions.
 - (h) Place the TE in the off-hook state. Measure the signal power that would be delivered to the data equipment from the network through the TE in response to a received signal power of -55 dBm. Return the TE to its on-hook state.

- (i) Increase the input signal 0 dBm.
- (j) Set the oscilloscope to trigger on transition from the on-hook to the off-hook state of the TE.
- (k) Apply the ringing signal to the TE.
- (l) Measure the signal power that would be received by the data equipment from the network through the TE. The signal level measured in this step (l) should be no greater than the signal level in step (h).

Note: The 2-second delay before transmission of the data signal, after the off-hook condition is presented to the telephone network in response to an incoming call, is to allow billing equipment to be connected and prepared for proper billing.

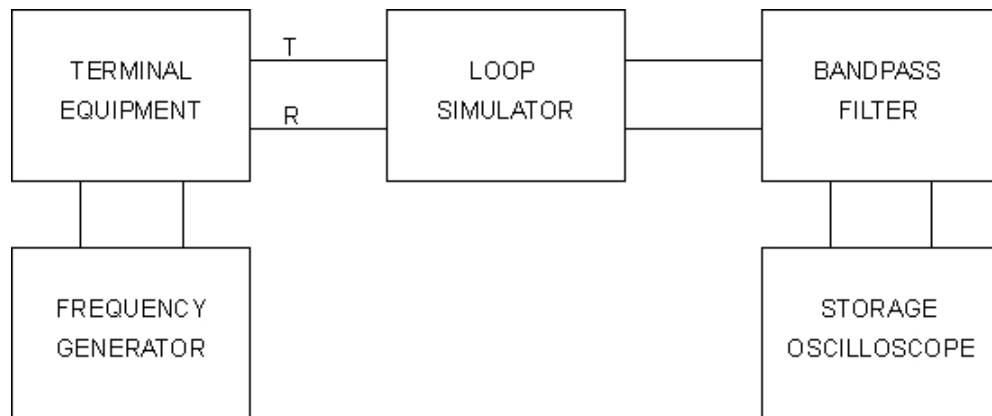

Figure 3.5(a): Call Duration, PC, Transmit

Note: Select the appropriate loop simulator for the interface of the TE.

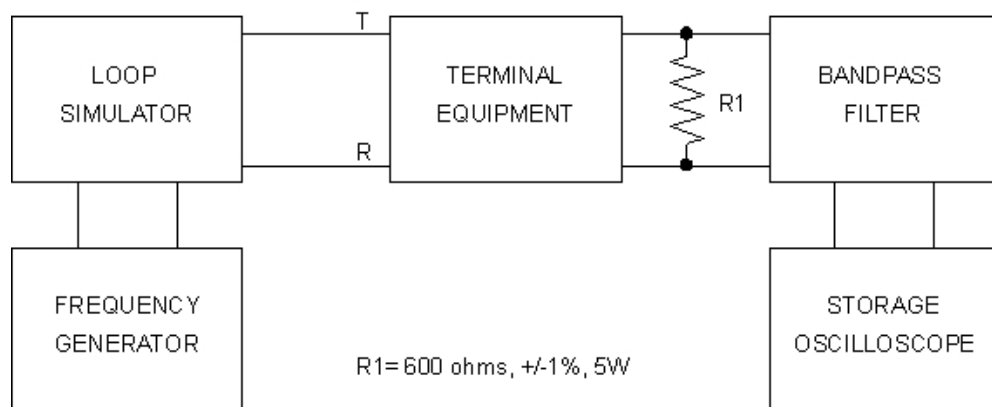

Figure 3.5(b): Call Duration, PC, Receive

Note: Select the appropriate loop simulator for the interface of the TE.

(2) For data equipment that accesses the public switched network:

- (a) Connect the TE to the test circuit of Figure 3.5(c).
- (b) Set the oscilloscope to trigger on the transition from the on-hook to the off-hook state.
- (c) Apply the ringing signal to the TE.
- (d) Monitor the signal transmitted by the TE for at least 2 seconds after the on-hook to off-hook transition, under normal operating conditions. Verify that data transmission is delayed for the required time. If a signal is observed in less than the required time, verify that it is one of the allowed signals.
- (e) Connect the TE to the test circuit of Figure 3.5(d).
- (f) Set the TE to receive data.
- (g) Set the oscilloscope to trigger on the transition from the on-hook to the off-hook state of the TE.
- (h) Apply the ringing signal to the TE.
- (i) Monitor the TE to verify that it does not respond to the incoming data for the time specified in the test requirement after going off-hook.

Note: The 2-second delay after transmission of the data signal, after the off-hook condition is presented to the telephone network in response to an incoming call, is to allow billing equipment to be connected and prepared for proper billing.

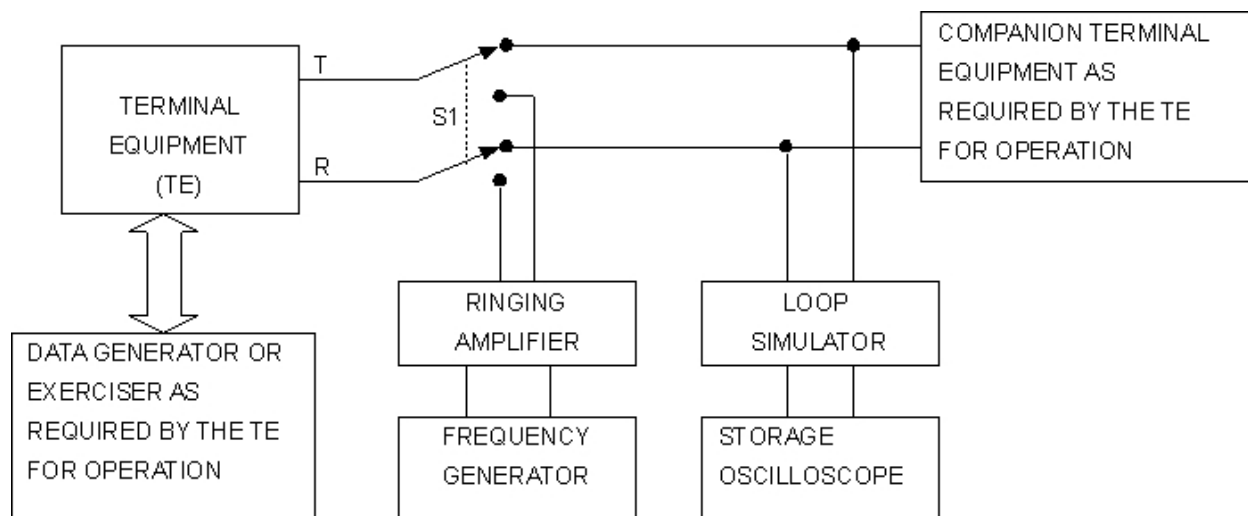

Figure 3.5(c): Call Duration, TE, Transmit

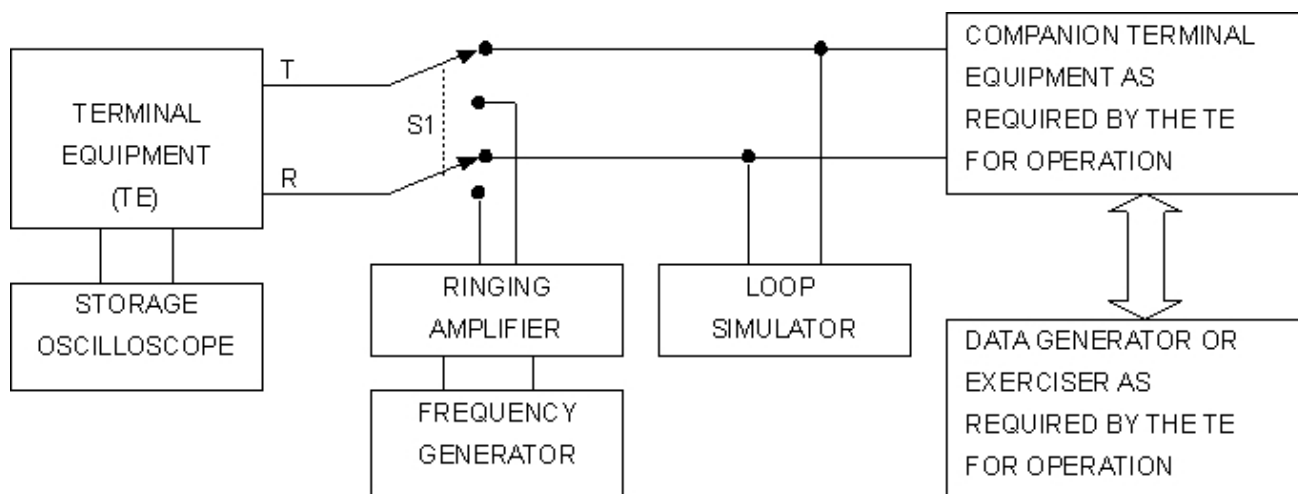

Figure 3.5(d): Call Duration, EUT, Receive

3.5.2 Voice and Data Equipment

3.5.2.1 Requirements

The loop current through the TE, when connected to a 2-wire or 4-wire loop simulator circuit with the 600 ohm resistor and 500 microfarad capacitor of the 2-wire loop simulator circuit or both pairs of the 4-wire loop simulator circuit disconnected shall, for at least 5 seconds after the equipment goes to the off-hook state which would occur when answering an incoming call:

- (1) Be at least as great as the current obtained in the same loop simulator circuit with a 200 ohm resistor connected across the tip and ring of the 2-wire loop simulator circuit or connected across the tip/ring and tip_1/ring_1 conductors (tip and ring connected together and tip_1 and ring_1 connected together) of the 4-wire loop simulator circuit in place of the TE; or
- (2) Not decrease by more than 25 % from its maximum value attained during this 5-second interval, unless the equipment is returned to the on-hook state during the above 5-second interval.
- (3) The above requirements also apply in the hold state.

3.5.2.2 Method of Measurement

To test for compliance with section:

3.5.2.1 (1) follow steps (1) to (11);

3.5.2.1 (2) follow steps (1) to (3) and (12) to (21).

- (1) Connect the TE as shown in Figure 3.5(e) and with switch S1 in position “a”, S2 in position “a”, and S3 in position “a”.

- (2) Adjust the DC voltage of B1 to 42.5 Vdc. Operate switch S3 to position “c”. Using an ohmmeter, adjust the total resistance to 1740 ohms by varying R. Operate switch S3 to position “a” and operate switch S1 to position “b”.
- (3) With B2 set at 52.5 Vdc, unless otherwise specified in the manufacturer’s manual, operate switch S2 momentarily to position “b” to apply ringing voltage.
- (4) Bring the TE to the off-hook state as defined in the manufacturer’s manual. Monitor the DC current for the first 5 seconds after transferring from the on-hook to the off-hook state. Record the minimum current. Return the TE to the on-hook state.
- (5) Operate switch S3 to position “b” and repeat steps (3) and (4).
- (6) Replace the TE with a 200 ohm, $\pm 1\%$, 5 W resistor. Operate switch S3 to position “a” and operate switch S1 to position “b”. Allow time for the current to settle before recording the value. Measure and record the DC current. Operate switch S3 to position “b” and measure and record the DC current.

Note: If the current drawn by the TE in step (4) is equal to or greater than the DC current measured with the 200 ohm resistor, then the requirement is met.

- (7) Reconnect the TE as shown in Figure 3.5(e). Adjust the DC voltage of B1 to 52.5 Vdc. Operate switch S1 to position “a” and operate switch S3 to position “c”. Using an ohmmeter, adjust the total resistance to 1200 ohms by varying R. Operate switch S3 to position “a” and then operate switch S1 to position “b”.
- (8) Repeat steps (3) to (6).
- (9) Reconnect the TE as shown in Figure 3.5(e). Leave the DC voltage of B1 set at 52.5 Vdc. Leave switch S1 in position “a” and then operate switch S3 to position “c”. Using an ohmmeter, adjust the total resistance to 400 ohms by varying R. Operate switch S3 to position “a” and then operate switch S1 to position “b”.
- (10) Repeat steps (3) to (6).
- (11) Repeat steps (1) to (10) for all remaining off-hook states of the TE.

Note: This is the end of the test method for demonstrating compliance with Section 3.5.2.1 (1). Steps (12) to (21) are for demonstrating compliance with Section 3.5.2.1 (2).

- (12) Connect the TE as shown in Figure 3.5(e). Adjust the DC voltage of B1 to 42.5 Vdc. Operate switch S1 to position “a” and operate switch S3 to position “c”. Using an ohmmeter, adjust the total resistance to 1740 ohms by varying R. Operate switch S3 to position “a” and operate switch S1 to position “b”.

- (13) With B2 set at 52.5 Vdc unless otherwise specified in the manufacturer's manual, operate switch S2 momentarily to position "b" to apply ringing voltage.
- (14) Monitor the values of DC current flow through the TE for a 5-second interval immediately following the transition from on-hook to off-hook and record the minimum and maximum values. Calculate the % change.
- (15) Operate switch S3 to position "b" and repeat steps (13) and (14).
- (16) Adjust the DC voltage of B1 to 52.5 Vdc. Operate switch S1 to position "a" and operate switch S3 to position "c". Using an ohmmeter, adjust the total resistance to 1200 ohms by varying R. Operate switch S3 to position "a" and operate switch S1 to position "b".
- (17) Operate switch S3 to position "b" and repeat steps (13) to (15).
- (18) Leave the DC voltage of B1 set at 52.5 Vdc. Operate switch S1 to position "a" and operate switch S3 to position "c". Using an ohmmeter, adjust the total resistance to 400 ohms by varying R. Operate switch S3 to position "a" and operate switch S1 to position "b".
- (19) Operate switch S3 to position "b" and repeat steps (13) to (15).
- (20) Return switches S1 and S3 to their respective positions "a".
- (21) Repeat steps (12) to (20) for all of the remaining off-hook states of the TE.

Note: This is the end of the test method for demonstrating compliance with Section 3.5.2.1(2).

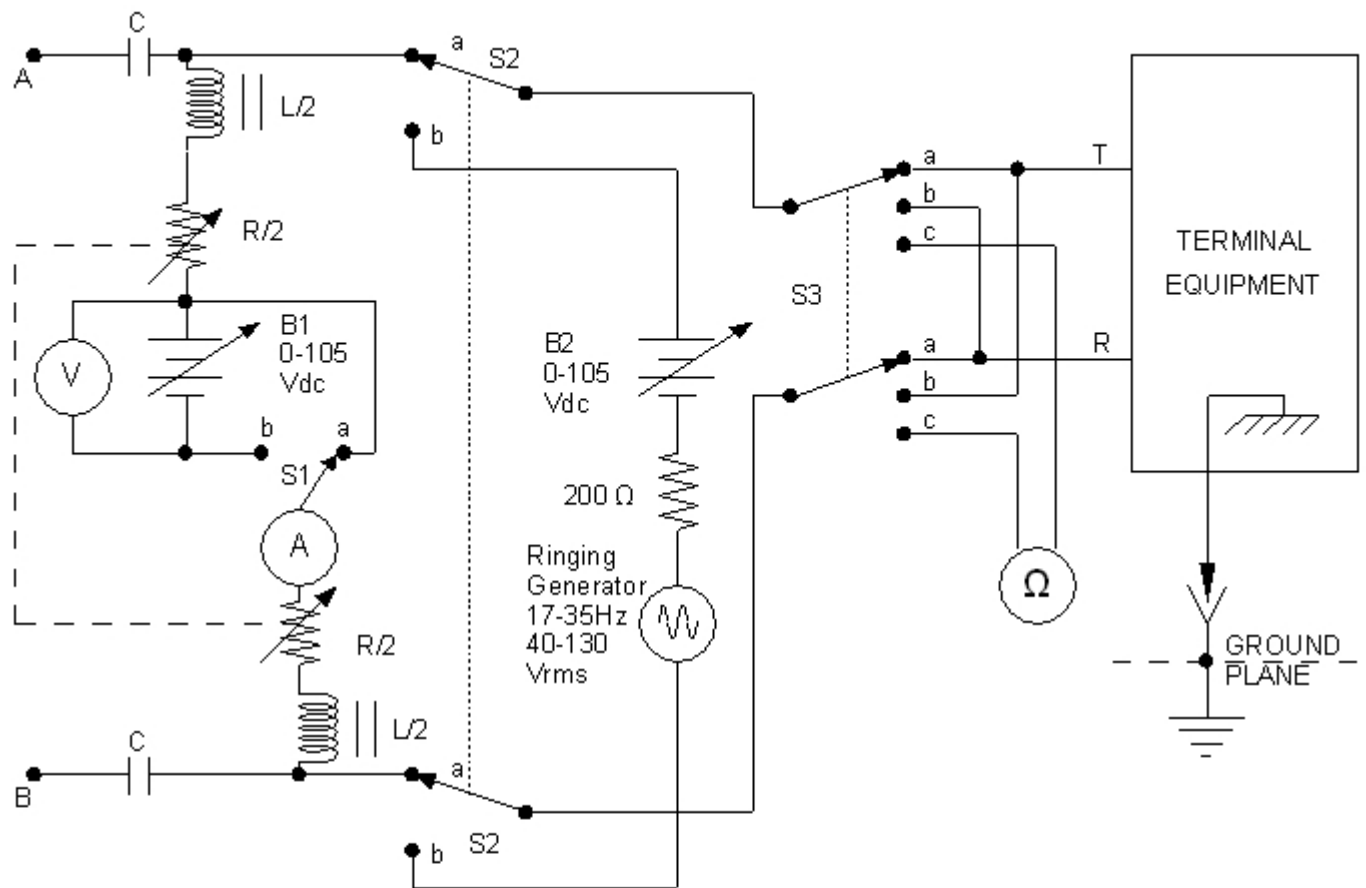

- LEGEND:**
- L – Inductor, 10H (min.) at 120 mADC, 200 ohm $\pm 10\%$ resistance
 - C – Non-electrolytic capacitor, 500 μ F, 300 Vdc, matched within 1%
 - B1 & B2 – Power supply, 0-105 Vdc, 500 mA
 - R – Linear potentiometer, 3 kohms, 8W
 - A – Ammeter, $\pm 1\%$ accuracy, 0 – 150 mA range
 - S1 – Switch
 - S2 – Ring-up key, momentary make
 - S3 – Polarity reversal / ohmmeter switch
 - V – Voltmeter, $\pm 1\%$ accuracy, 0-105 Vdc
 - Ω – Ohmmeter, $\pm 1\%$ accuracy, 2 kohm range

Figure 3.5(e): Billing Protection Measurement

3.5.3 Signalling Interference

3.5.3.1 Requirements

The signal power delivered to the network interface by the TE and from signal sources internal to network protection devices in the 2450 Hz to 2750 Hz band shall be less than or equal to the power present simultaneously in the 800 Hz to 2450 Hz band for the first 2 seconds after going to the off-hook state.

3.5.3.2 Method of Measurement

- (1) Connect the TE to the test circuit as shown in Figure 3.5(f).
- (2) Set the Signal Analyzer to capture the maximum signal power in the 800 Hz to 2750 Hz band (power level in dBm measured against 600 ohms with a 2-second average).
- (3) Initiate a call to the TE.
- (4) Using band power markers, measure the maximum signal power in the 800 Hz to 2450 Hz band and in the 2450 Hz to 2750 Hz band after the TE goes off-hook for the first 2 seconds.
- (5) Compare the energy in the 2450 Hz to 2750 Hz band to the energy in the 800 Hz to 2450 Hz band. The 2450 Hz to 2750 Hz band shall be less than or equal to the power present simultaneously in the 800 Hz to 2450 Hz band.
- (6) Compute the ratio: $\frac{\text{Guard Band Vac}}{\text{Signalling Band Vac}}$
- (7) Repeat Steps (3) to (5) for all other call answering modes, if applicable.

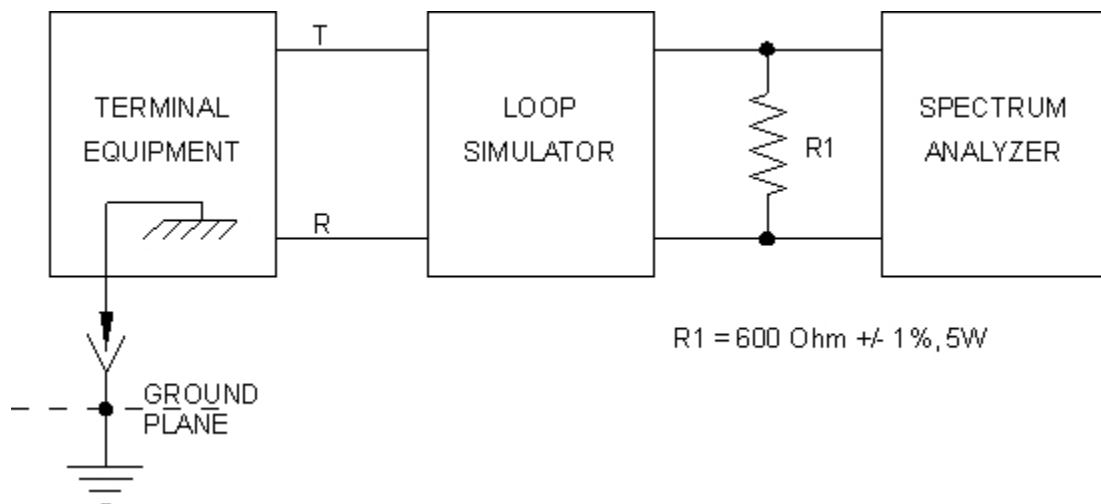

Figure 3.5(f): Single Frequency Restriction Method of Measurement

Note: When the TE makes provision for an external connection to ground (G), the TE shall be connected to ground. When the TE makes no provision for an external ground, the TE shall be placed on a ground plane which is connected to ground and has overall dimensions at least 50% greater than the corresponding dimensions of the TE. The TE shall be centrally located on the ground plane without any additional connection to ground.

3.5.4 Answer Supervision - Operating Requirements for Direct Inward Dialling (Reverse Battery Trunk Interface)

3.5.4.1 Requirements

For TE connected to reverse battery trunk interface, the off-hook state shall be applied within 0.5 seconds of the time that:

- (1) The TE permits the acceptance of further digits that may be used to route the incoming call to another destination.
- (2) The TE transmits signals towards the calling party, except the call progress tones (e.g. busy, reorder, and audible ring) and the call is:
 - (a) Answered by the called, or another station;
 - (b) Answered by the attendant;
 - (c) Routed to a customer-controlled or defined recorded announcement, except for “number invalid”, “not in service” or “not assigned”;
 - (d) Routed to a dial prompt; or
 - (e) Routed back to the PSTN or other destination and the call is answered. If the status of the answered call cannot reliably be determined by the TE through means such as detection of answer supervision or voice energy, removal of audible ring, etc., the off-hook state shall be applied after an interval of not more than 20 seconds from the time of such routing.

The off-hook state shall be maintained for the duration of the call.

3.5.4.2 For Network Protection Devices

- (1) Network protection devices shall block transmissions incoming from the network until an off-hook signal is received from the TE.
- (2) Network protection devices shall provide an off-hook signal within 0.5 seconds following the receipt of an off-hook signal from the TE and shall maintain this off-hook signal for the duration of the call.

3.5.4.3 Method of Measurement

- (1) Connect the companion terminal equipment and the digital DC voltmeter to the tip and ring leads of the TE as shown in Figure 3.5(g).
- (2) Connect the digital DC voltmeter across the tip and ring leads of the TE.

- (3) Connect the companion terminal equipment (e.g. a telephone) to the called station under test.
- (4) Connect channel 1 of the storage oscilloscope (between ring lead and ground) to the TE.
- (5) Connect channel 2 of the storage oscilloscope (between ring lead and ground) to the called station under test.
- (6) Originate a direct inward dialling call from the companion terminal equipment.
- (7) Monitor the TE line loop polarity with the digital DC voltmeter.
- (8) Observe and record, with the storage oscilloscope, the elapsed period between the time that the called PBX station goes off-hook to answer the call and the time that the TE transmitted the line reversed answer supervision signal to the network.
- (9) Ensure that the line reversed answer supervision state is maintained for the duration of the call.
- (10) Repeat steps (6) to (9) for each call answering mode (i.e. answered by the attendant, answered by a recorded message, forwarded call to another trunk, etc.).

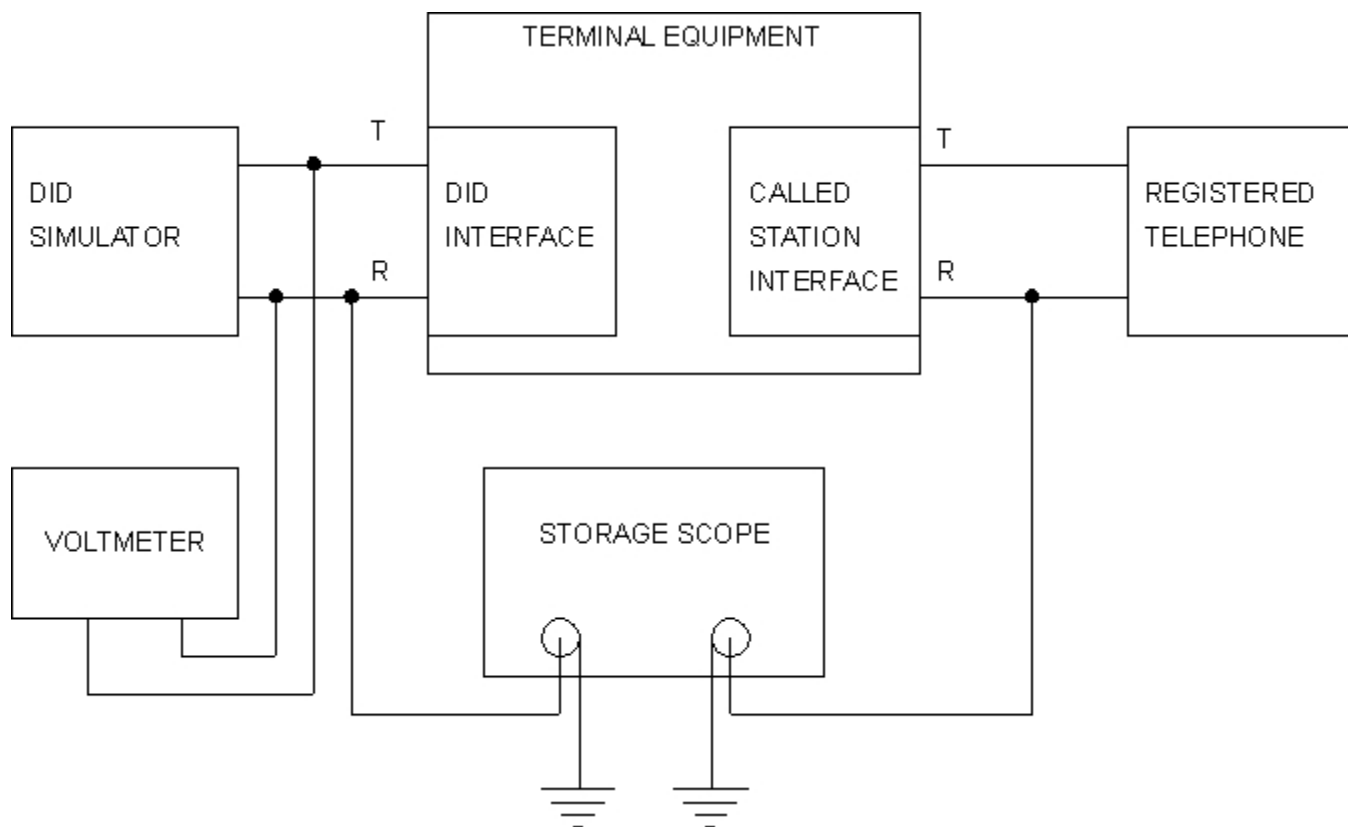

Figure 3.5(g): Analogue Direct Inward Dialling

3.6 Transverse Balance

3.6.1 Requirements and Application

The metallic-to-longitudinal balance coefficient, Transverse Balance m_{-l} , is expressed as:

$$\text{Balance}_{M-L}(\text{dB}) = 20 \log (V_M/V_L)$$

Where V_L is the longitudinal voltage produced across a longitudinal termination Z_l , and V_M is the metallic voltage across the tip and ring or tip_1 and ring_1 interface of the input port when a voltage (at any frequency between $f_1 < f < f_2$, see Table 3.6) is applied from a balanced source with a metallic impedance Z_0 (see Table 3.6). The source voltage should be set such that $V_M = E$ volts (see Table 3.6) when a termination of Z_0 is substituted for the TE.

Table 3.6

Parameters	Analogue Voice Band
Longitudinal Termination - Z_l	500 Ω
Metallic Source Impedance - Z_0	600 Ω
Lower Frequency - f_1	200 Hz
Upper Frequency- f_2	4000 Hz
Metallic Voltage for Test - E	0.775 V

The minimum transverse balance coefficient specified in this section (as appropriate) shall be equalled or exceeded for all 2-wire network ports, OPS line ports and the transmit pair (tip and ring) and receive pair (tip_1 and ring_1) of all 4-wire network ports at all values of DC loop current that the port under test is capable of drawing when attached to the appropriate loop simulator circuit.

An illustrative test circuit that satisfies the above conditions is shown in Figure 3.6(a).

The minimum transverse balance requirements specified below shall be equalled or exceeded under all reasonable conditions of the application of earth ground to the equipment or protective circuitry under test.

3.6.2 Analogue Voice Band Equipment

All analogue voice band equipment shall be tested in the off-hook state. The transverse balance requirement in the off-hook state is 40 dB throughout the range of frequencies specified in Table 3.6. For some categories of TE, additional requirements also apply to the on-hook state. When both off-hook and on-hook requirements apply, they are:

Off-hook	200 Hz	≤	Freq	≤	4000 Hz	≥	40 dB
On-hook	200 Hz	≤	Freq	≤	1000 Hz	≥	60 dB
	1000 Hz	<	Freq	≤	4000 Hz	≥	40 dB

- (1) For analogue one-port 2-wire TE with loop-start, ringdown, or in-band signalling; or for voice band metallic channel applications, both off-hook and on-hook requirements apply.
- (2) For analogue one-port equipment with ground-start and reverse-battery signalling, only off-hook requirements apply.
- (3) For analogue network protection devices for 2-wire applications with loop-start, ringdown, or in-band signalling; or for voice band metallic channel applications, both off-hook and on-hook requirements apply.
- (4) The requirements of transverse balance shall be met while in the hold state. Any internal source of audio may be inhibited for this test and any external source may be connected to a quiet termination.

Criteria shall be met with either terminal of the interface to other equipment connected to earth ground. The interface to other equipment shall be terminated in an impedance which will be reflected to the TE connection as 600 ohms in the off-hook state of the protective circuit, and the interface should not be terminated in the on-hook state. Figures 3.6(c) and (d) show the interfaces of the protective circuitry being tested and the required arrangement at the interface to other equipment.

- (5) For analogue network protection devices with ground-start and reverse-battery signalling, only off-hook requirements apply.

These criteria shall be met with either terminal of the interface to other equipment connected to earth ground. The interface to other equipment shall be terminated in an impedance which will be reflected to the telephone connection as 600 ohms in the off-hook state of the protective circuit. Figures 3.6(c) and (d) show the interface of the protective circuitry under test and the required arrangement at the interface to the other equipment.

- (6) For analogue multi-port equipment with loop-start signalling, both off-hook and on-hook requirements apply.

These criteria shall be satisfied for all ports when the ports are terminated in their appropriate networks, as will be identified below, and when interface connections other than the ports are terminated in circuits appropriate to that interface. The minimum transverse balance coefficients shall also be satisfied for all values of DC loop current that the TE is capable of drawing through each of its ports when these ports are attached to the loop simulator circuit specified in these rules. The termination for all ports, other than the particular one whose transverse balance coefficient is being measured, shall have a metallic impedance of 600 ohms and a longitudinal impedance of 500 ohms. Figure 3.6(e) shows this termination.

- (7) For analogue multi-port equipment with ground-start and reverse-battery signalling, only off-hook requirements apply.

These criteria shall be satisfied for all ports when all ports not under test are terminated in their appropriate networks, as will be identified below, and when interface connections other than the ports are terminated in circuits appropriate to that interface. The minimum transverse balance coefficients shall be satisfied for all values of DC loop current that the TE is capable of drawing through each of its ports when these ports are attached to the loop simulator circuit specified in these rules. The termination for all ports, other than the particular one whose transverse balance coefficient is being measured, shall have a metallic impedance of 600 ohms and a longitudinal impedance of 500 ohms. Figure 3.6(e) shows this termination.

- (8) For analogue TE and network protection devices for 4-wire network ports, both the off-hook and on-hook requirements apply.

The pair not under test shall be terminated in a metallic impedance of 600 ohms. Other conditions are as follows:

- (a) For analogue protective circuitry with loop-start, ground-start, reverse battery, ringdown, or in-band signalling; or for voice band metallic channel applications.

These criteria shall be met with either terminal of the interface to other equipment connected to earth ground. The interface to other equipment shall be terminated in an impedance that will result in 600 ohms at each of the transmit and receive pairs of the 4-wire telephone connection in the off-hook state of the protective circuit, and the interface should not be terminated in the on-hook state. Figure 3.6(c) shows the interface of the network protection devices being tested and the required arrangement at the interface to other equipment.

- (b) For analogue multi-port equipment with loop-start, ground-start, and reverse battery, ringdown, or in-band signalling; or for voice band metallic channel applications.

These criteria shall be satisfied for all network ports when the ports are terminated as defined below, and when interface connections other than the network ports are terminated in circuits appropriate to the interface. The criteria shall also be satisfied for all values of DC loop current when the port is connected to the appropriate 4-wire loop simulator circuit. The terminations for both pairs of all network ports not under test shall have a metallic impedance of 600 ohms and a longitudinal impedance of 500 ohms. Figure 3.6(e) shows this termination.

- (9) For analogue multiple-line equipment (or similar systems) with Class B or Class C off-premises interfaces, only off-hook requirements apply.

These criteria shall be satisfied for all off-premises station interface ports when these ports are terminated in their appropriate networks for their off-hook state, and when all other interface connections are terminated in circuits appropriate to that interface. The minimum transverse balance coefficients shall also be satisfied for all values of DC loop current that the registered PBX is capable of providing through off-premises station ports when these ports are attached to the off-premises line simulator circuit specified.

3.6.3 Method of Measurement

- (1) Connect a 600 ohm resistor to the test circuit of Figure 3.6(a).
- (2) Set the frequency generator to 200 Hz.
- (3) Adjust the frequency generator to an output level of 0.775 V rms as measured by the frequency selective voltmeter set at 10 Hz bandwidth and balanced input, across the 600 ohm calibration resistor.
- (4) Connect the frequency selective voltmeter across the 500 ohm longitudinal termination resistor.
- (5) Adjust variable capacitors C3 and C4 until the minimum level across the 500 ohm resistor is obtained. This represents the highest degree to which the bridge can be balanced at the frequency being measured referenced to the level set in step (3). The result of this balance calibration must be at least 20 dB greater than the balance requirement for the TE at that frequency (See Figure 3.6(a) Note (2)).
- (6) Remove the 600 ohm resistor and connect the balance test set to the TE as shown in Figure 3.6(b), or (c), or (d).
- (7) Vary the loop current, for off-hook conditions, over the available range of loop current (maximum 70 mA), observing the worst-case balance (maximum voltage across the 500 ohm resistor).
- (8) Return the loop simulator to the condition resulting in the worst-case balance noted in step (7).
- (9) Measure the voltage across the tip and ring of the TE. This is the metallic reference voltage (V_M).
- (10) Measure the voltage across the 500 ohm resistor. This is the longitudinal voltage (V_L).
- (11) Calculate the balance using the following formula:

$$\text{Balance (dB)} = 20 \log (V_M/V_L)$$

- (12) Reverse the tip and ring connections of the TE and repeat steps (9) to (11). The lesser of the two results is the transverse balance of the TE at 200 Hz.

- (13) Repeat steps (3) to (12) for at least each of the following frequencies: 500, 1000, 2000, 3000, and 4000 Hz, with the resolution bandwidth set for 10 Hz for the 500 Hz measurement and 30 Hz for all other frequencies.
- (14) Repeat steps (2) to (13) for all applicable TE states.

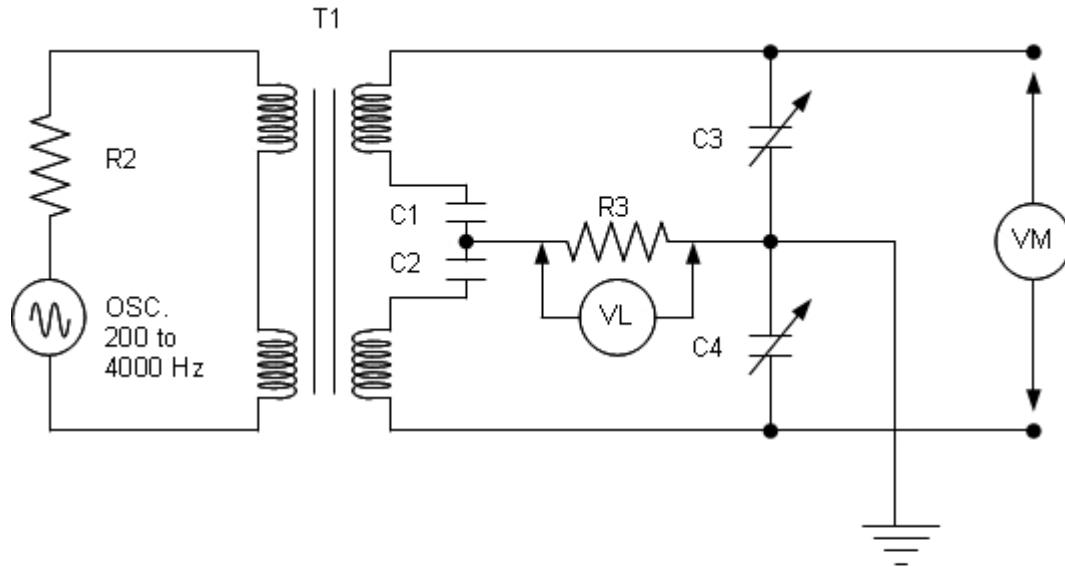

- LEGEND:** T1 – 600 Ohm, 1:1, Line Matching Transformer.
 C1, C2 – 8 μ F, 400 Vdc, matched to within 0.1%.
 C3, C4 – 100 to 500 pF adjustable trimmer capacitors.
 OSC. – Oscillator with a source resistance $R_1 \leq 600$ ohm.
 R2 – Selected such that $Z_{osc} + R_2 = 600$ ohms.
 R3 – 500 Ohms.

Figure 3.6(a): Transverse Balance Measurement Test Set

Notes:

- (1) V_M should not be measured at the same time as V_L .
- (2) Use trimmer capacitors C3 and C4 to balance test circuit to 20 dB greater balance than the equipment standard for all frequencies specified, with a 600 ohm resistor substituted for the equipment under test.
- (3) Exposed conductive surfaces on the exterior of the equipment under test should be connected to the ground plane for this test.

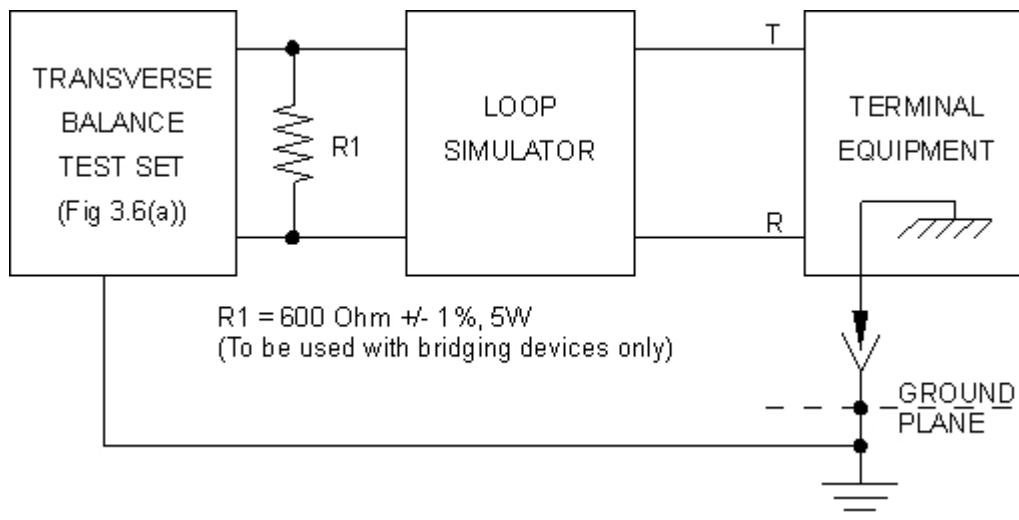

Figure 3.6(b): Transverse Balance Method of Measurement (TE)

Note: When the TE makes provision for an external connection to ground (G), the TE shall be connected to ground. When the TE makes no provision for an external ground, the TE shall be placed on the ground plane which is connected to ground and has overall dimensions at least 50% greater than the corresponding dimensions of the TE. The TE shall be centrally located on the ground plane without any additional connection to ground.

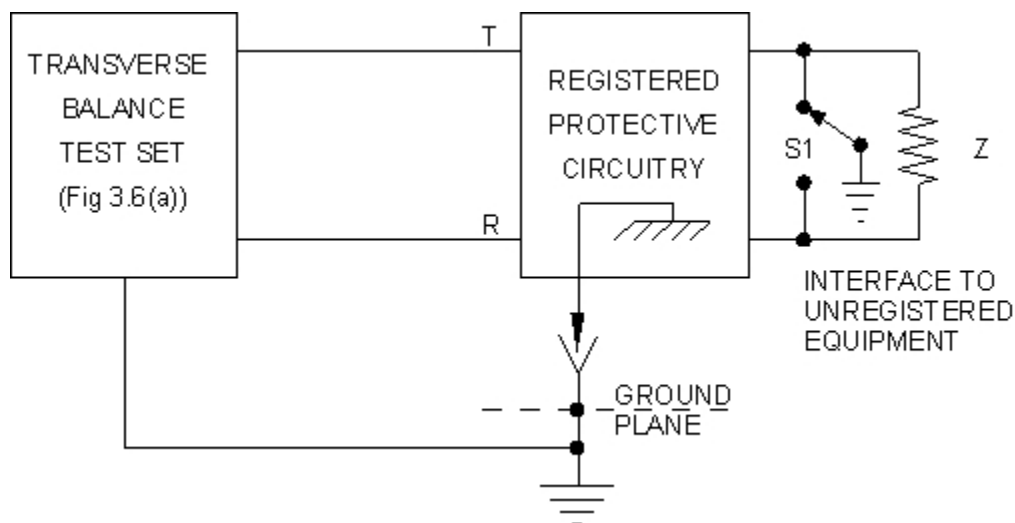

Figure 3.6(c): Required Termination for Connections to Unregistered Equipment, 2-Wire TE

Note: Z is selected so that the reflected impedance at tip and ring is 600 ohms, depending on the service type of the TE.

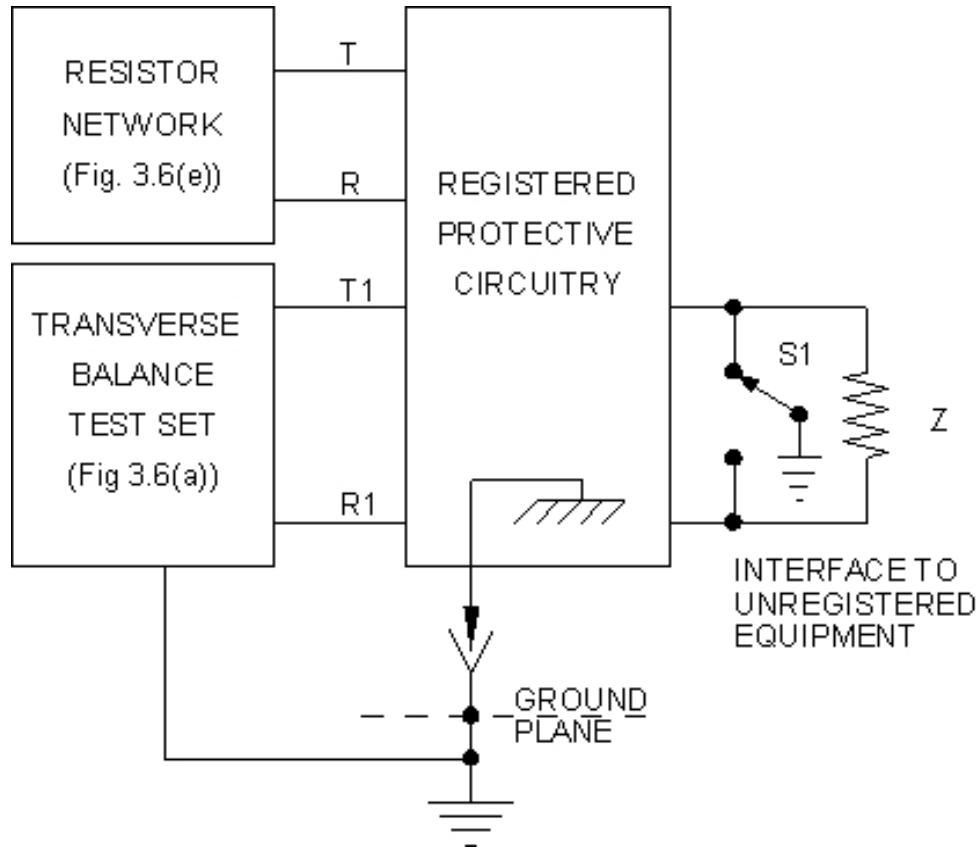
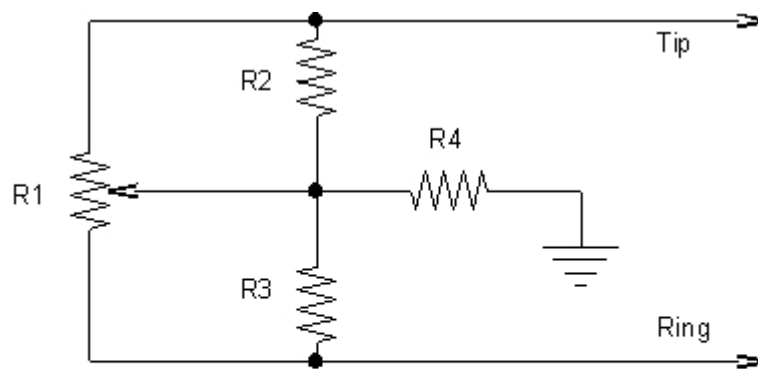

Figure 3.6(d): Required Termination for Connections to Unregistered Equipment, 4-Wire TE

Note: Z is selected so that the reflected impedance at tip and ring is 600 ohms, depending on the service type of the TE.



WHERE:

$R2 = R3 = 300 \text{ ohm}$, $R4 = 350 \text{ ohm}$, $R1 = 300 \text{ kohm}$
For Analogue Voice Band.

Figure 3.6(e): Off-hook Termination of Multi-port Equipment for Ports not under Test

3.7 On-hook Terminal Resistance and Impedance

3.7.1 Metallic and Longitudinal DC Resistance (Loop-start Interface)

3.7.1.1 Requirements

- (1) On-hook resistance, metallic and longitudinal (up to 100 Vdc).

The on-hook DC resistance between the tip and ring conductors of a loop-start interface, and between each of the tip and ring conductors and earth ground, shall be greater than 5 Mohms for all DC voltages up to and including 100 volts.

- (2) On-hook resistance, metallic and longitudinal (100 V to 200 Vdc).

The on-hook DC resistance between tip and ring conductors of a loop-start interface, and between each of the tip and ring conductors and earth ground, shall be greater than 30 Kohms for all DC voltages between 100 and 200 V.

3.7.1.2 Method of Measurement

- (1) Connect the TE to the test circuit of Figure 3.7(a).
- (2) Set switches S1 and S2 to position “a” and the voltage to 1 Vdc, allowing time for the circuit to stabilize.
- (3) Slowly increase the voltage to 100 volts and observe the current as the voltage is increased:
 - (a) If the current is less than 0.2 μ A over this range, measure and record the current at 1 volt. Use this value to calculate the minimum DC resistance from 1 to 100 volts.
 - (b) If the current increases suddenly at any point, record the voltage and current at these points. Calculate the DC at these points.
 - (c) In addition to any points recorded in step (b), measure and record the current and voltages of 1, 10, 20, 30, 40, 50, 60, 70, 80, 90, and 100 volts. Calculate the DC resistance at these voltages.
- (4) Slowly increase the voltage from 100 to 200 volts and observe the current as the voltage is increased:
 - (a) If the current is less than 3.3 mA over this range, measure and record the current at 100 volts. Use this value to calculate the minimum DC resistance from 100 to 200 volts.
 - (b) If the current increases suddenly at any point, record the voltage and current at these points. Calculate the DC resistance at these points.

- (c) In addition to any points recorded in step (b), measure and record the current at voltages of 100, 150, and 200 volts.
- (5) Reverse the polarity of the test circuit and repeat steps (2) to (4).
- (6) Connect the TE to the test circuit in Figure 3.7(a). Set switches S1 to position “a” and S2 to position “b”.
- (7) Repeat steps (2) to (5), with connections made to the tip and ground leads of the TE.
- (8) Set switches S1 and S2 to position “b”.
- (9) Repeat steps (2) to (5), with connections made to the ring and ground leads of the TE.

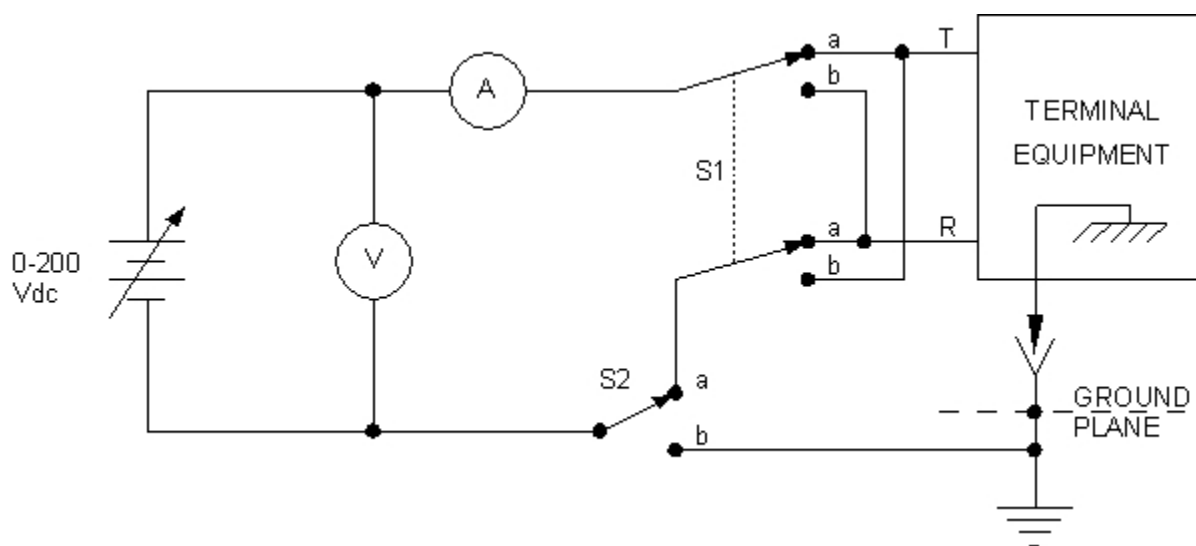

Figure 3.7(a): On-hook Terminal Resistance Measurement

Note: When the TE makes provision for an external connection to ground (G), the TE shall be connected to ground. When the TE makes no provision for an external ground, the TE shall be placed on a ground plane which is connected to ground and has overall dimensions at least 50% greater than the corresponding dimensions of the TE. The TE shall be centrally located on the ground plane without any additional connection to ground.

3.7.2 DC Current during Ringing (Loop-start and Ground-start Interfaces)

3.7.2.1 Requirements

- (1) During the application of simulated ringing (as listed in Table 3.7(a)) to a loop-start interface, the total DC current shall not exceed 3.0 mA.

- (2) During the application of simulated ringing (as listed in Table 3.7(a)) to a ground-start interface, the total DC current shall not exceed 3.0 mA.

3.7.2.2 Method of Measurement of DC Current During Ringing

- (1) Connect the TE to the test circuit of Figure 3.7(b).
- (2) Set the test equipment to supply the lowest frequency and voltage listed in Table 3.7(a).
- (3) Record the DC current.
- (4) Increase the ringing voltage to the maximum value.
- (5) Record the maximum DC current.
- (6) Repeat steps (3) to (5) for the other frequency.
- (7) Reverse the connections of the TE to the test circuit and repeat steps (2) to (6).

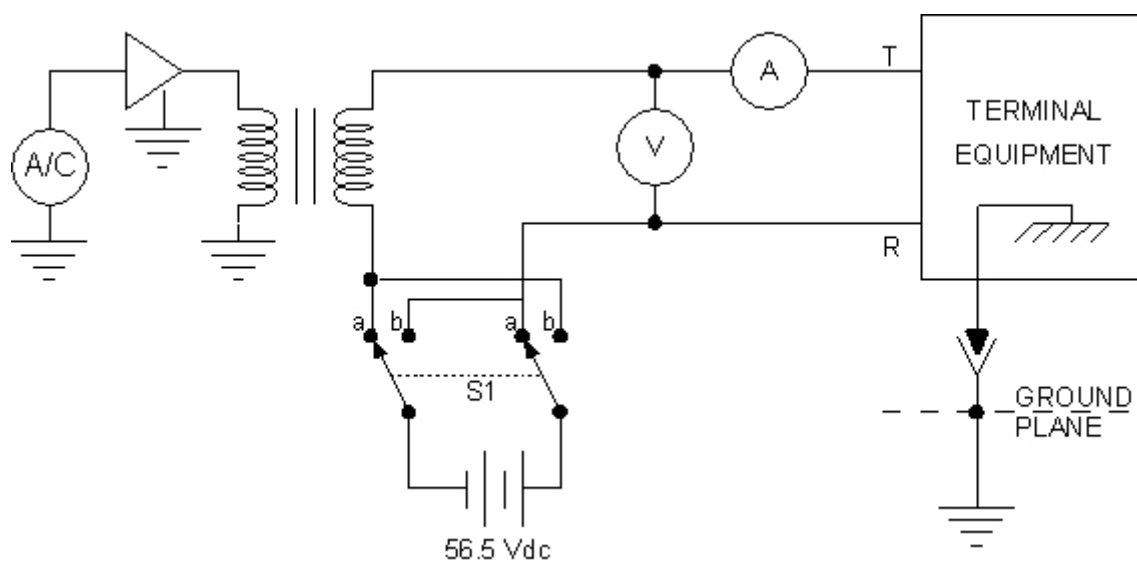

Figure 3.7(b): On-hook Metallic Impedance Measurement

3.7.3 Metallic and Longitudinal Impedance During Ringing (Loop-start and Ground-start Interfaces)

3.7.3.1 Requirements

- (1) During the application of simulated ringing (as listed in Table 3.7(a)) to a loop-start or a ground-start interface, the impedance between the tip and ring conductors (defined as the quotient of applied AC voltage divided by resulting true rms current) shall be greater than the value specified in Table 3.7(a).

- (2) During the application of simulated ringing (as listed in Table 3.7(a)) to a loop-start interface, the impedance between each of the tip and ring conductors and ground shall be greater than 100 kohms.

Table 3.7(a)

Range of Compatible Ringing Frequencies (Hz)	Simulated Ringing Voltage Superimposed on 56.5 volts DC	Impedance Limitation (ohms)
20 ± 3	40 to 130 volts rms	1400
30 ± 3	40 to 130 volts rms	1000

3.7.3.2 Method of Measurement for Ringing Impedance

- (1) Connect the TE to the test circuit of Figure 3.7(b).
- (2) Set the frequency generator to the lowest frequency and voltage listed in Table 3.7(a).
- (3) Record the current.
- (4) Calculate the AC impedance of the TE.
- (5) Increase the ringing voltage to the maximum as indicated in Table 3.7(a).
- (6) Record the current.
- (7) Calculate the AC impedance of the TE.
- (8) Repeat steps (2) to (7) for the other frequency.
- (9) Reverse the connections of the TE to the test circuit and repeat steps (2) to (8).

Loop-start only:

- (10) Connect the TE to the test circuit of Figure 3.7(c).
- (11) Repeat steps (2) to (9).

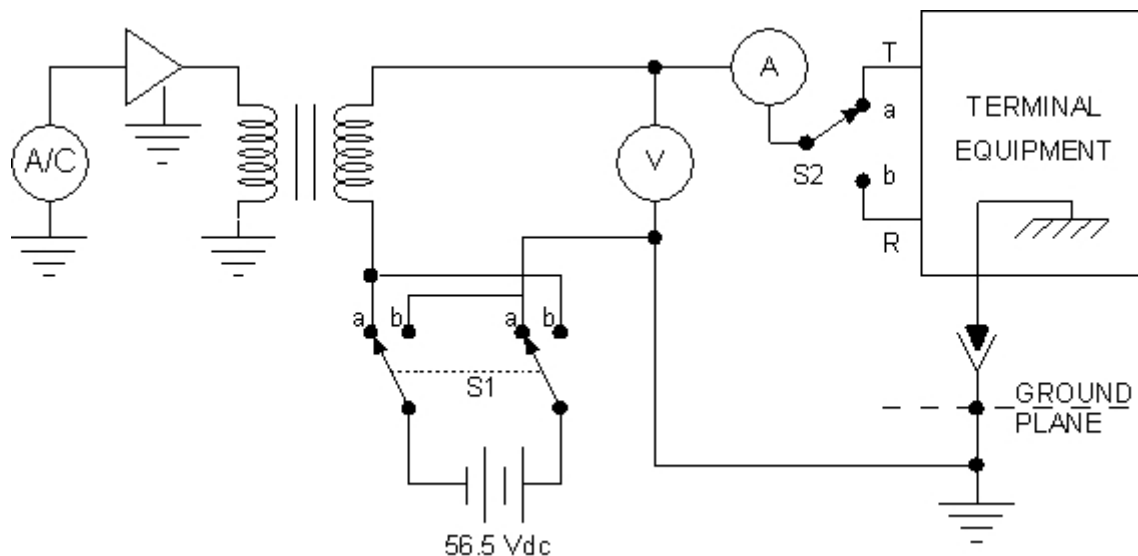

Figure 3.7(c): On-hook Longitudinal Impedance Measurement

3.7.4 OPS Interface for PBX with DID - Ring Trip Requirements

PBX ringing supplies whose output appears on the off-premises interface leads shall not trip when connected to the following tip to ring impedance that terminates the off-premises station loop: a terminating impedance composed of the parallel combination of a 15 kohms resistor and an RC in series circuit (resister and capacitor) whose AC impedance is as specified in Table 3.7(b).

Table 3.7(b)

Ringing freq (Hz)	AC impedance (ohms)	
	Class B or C	Class A
20 ± 3	$7000/N$	1400
30 ± 3	$500/N$	1000

N = Number of ringer equivalence, as specified by the manufacturer, which can be connected to the off-premises station loop.

3.7.4.1 Method of Measurement

- (1) Calculate the value for R and C according to Section 3.7.4.
- (2) Connect the TE to the circuit of Figure 3.7(d).
- (3) Cause the TE to generate ringing toward the termination.

(4) Verify that ringing has not tripped.

Note: The PBX equipment is to be tested while it is ringing an off-premise station.

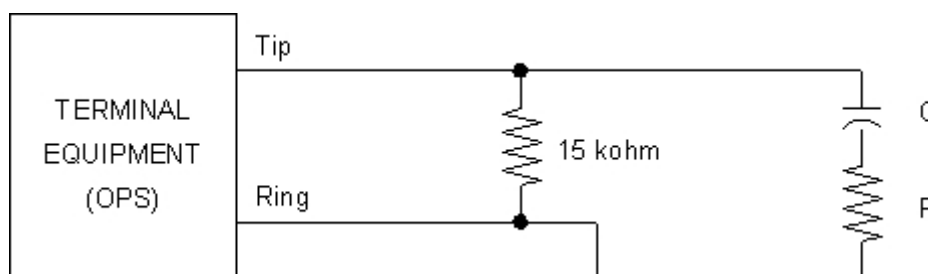

Figure 3.7(d): OPS Ring Trip

3.8 Idle State Terminal Impedance-return Loss and Transducer Loss (Tie Trunk Interface)

3.8.1 Requirements

Limitation on idle circuit stability parameters: for idle state operating conditions of TE and network protective devices, the following limitations shall be met:

(1) For the 2-wire interface:

$$RL \geq \begin{cases} 9 - 3 \frac{\log(f/200)}{\log(2.5)} \text{ dB} & ; \text{ for } 200 \text{ Hz} \leq f \leq 500 \text{ Hz} \\ 6 \text{ dB} & ; \text{ for } 500 \text{ Hz} \leq f \leq 3200 \text{ Hz} \end{cases}$$

(2) For the 4-wire lossless interface:

$$tl_f \geq \begin{cases} 10 - 4 \frac{\log(f/200)}{\log(2.5)} \text{ dB} & ; \text{ for } 200 \text{ Hz} \leq f \leq 500 \text{ Hz} \\ 6 \text{ dB} & ; \text{ for } 500 \text{ Hz} \leq f \leq 3200 \text{ Hz} \end{cases}$$

$$tl_r < 40 \text{ dB}$$

$$RL_i, RL_o \geq 3 \text{ dB}$$

Note: The following definitions apply to return loss requirements:

RL - the return loss of 2-wire TE at the interface with respect to 600 ohms + 2.16 μF
 (i.e. $Z_{ref} = 600 \text{ ohms} + 2.16 \mu\text{F}$):

$$RL \triangleq 20 \log_{10} \left| \frac{Z_{PBX} + Z_{REF}}{Z_{PBX} - Z_{REF}} \right|$$

RL_i - the TE input (receive) port return loss with respect to 600 ohms (i.e. $Z_{ref} = 600 \text{ ohms}$):

$$RL_i \triangleq 20 \log_{10} \left| \frac{Z_{PBX(input)} + Z_{REF}}{Z_{PBX(input)} - Z_{REF}} \right|$$

RL_o - the TE output (transmit) port return loss with respect to 600 ohms (i.e. $Z_{ref} = 600 \text{ ohms}$):

$$RL_o \triangleq 20 \log_{10} \left| \frac{Z_{PBX(OUTPUT)} + Z_{REF}}{Z_{PBX(OUTPUT)} - Z_{REF}} \right|$$

tl - the transducer loss between the receive and transmit ports of the 4-wire PBX:

tl_f is the transducer loss in the forward direction from the receive port to the transmit port of the PBX.

$$tl_f \triangleq 20 \log_{10} \left| \frac{I_i}{I_r} \right|$$

where I_i is the current sent into the receive port and I_r is the current received at the transmit port, terminated at 600 ohms.

tl_r is the transducer loss in the reverse direction, from the transmit port to the receive port of the PBX.

$$tl_r \triangleq 20 \log_{10} \left| \frac{I_i}{I_r} \right|$$

where I_i is the current sent into the transmit port and I_r is the current received at the receive port terminated at 600 ohms.

Note: The source impedance of I_i is 600 ohms.

3.8.1.1 Method of Measurement

2-Wire Return Loss

- (1) Connect the TE to the test circuit as shown in Figure 3.8(a). Refer to note for devices connected in series with tip and ring.

Note: When testing devices connected in series with tip and ring, terminate the output tip and ring terminals of the series device with 600 ohms in series with 2.16 μF , using an appropriate simulator circuit as shown in Section 4.0. Perform steps (1) to (4) at the input tip and ring terminals.

- (2) Set the tracking generator to 0.5 V rms (0.6 dBV) or higher, and manually or automatically sweep the band from 200 Hz to 3200 Hz as a minimum, with the spectrum analyzer measuring the level in dBV across points A and D (switch in position “a”). This is the reference level measurement.
- (3) Without adjusting the tracking generator level, manually or automatically sweep the same frequency band as used in step (2), with the spectrum analyzer now measuring the level in dBV across points B and C (switch in position “b”).
- (4) The difference in dB between the reference level measured in step (2) and the level measured in step (3) is the return loss of the TE port at any given frequency. The return loss will be a positive value.

4-Wire Return Loss

- (1) Connect the TE to the test circuit as shown in Figure 3.8(b). Refer to note for devices connected in series with tip and ring.

Note: When testing devices connected in series with tip and ring, terminate the output tip and ring terminals of the series device with 600 ohms using an appropriate simulator circuit as shown in Section 4.0. Perform steps (1) to (6) at the input tip and ring terminals.

- (2) Set the tracking generator to 0.5 V rms (0.6 dBV) or higher, and manually or automatically sweep the band from 200 Hz to 3200 Hz as a minimum, with the spectrum analyzer measuring the level in dBV, across points A and D (switch in position “a”). This is the reference level measurement.
- (3) Without adjusting the tracking generator level, manually or automatically sweep the same frequency band as used in step (2) with the spectrum analyzer now measuring the level in dBV, across points B and C (switch in position “b”).
- (4) The difference, in dB, between the reference level measured in step (2) and the level measured in step (3) is the return loss of the TE port at any given frequency. The return loss will be a positive value.
- (5) Connect the TE to the test circuit as shown in Figure 3.8(c).
- (6) Repeat steps (2) to (4).

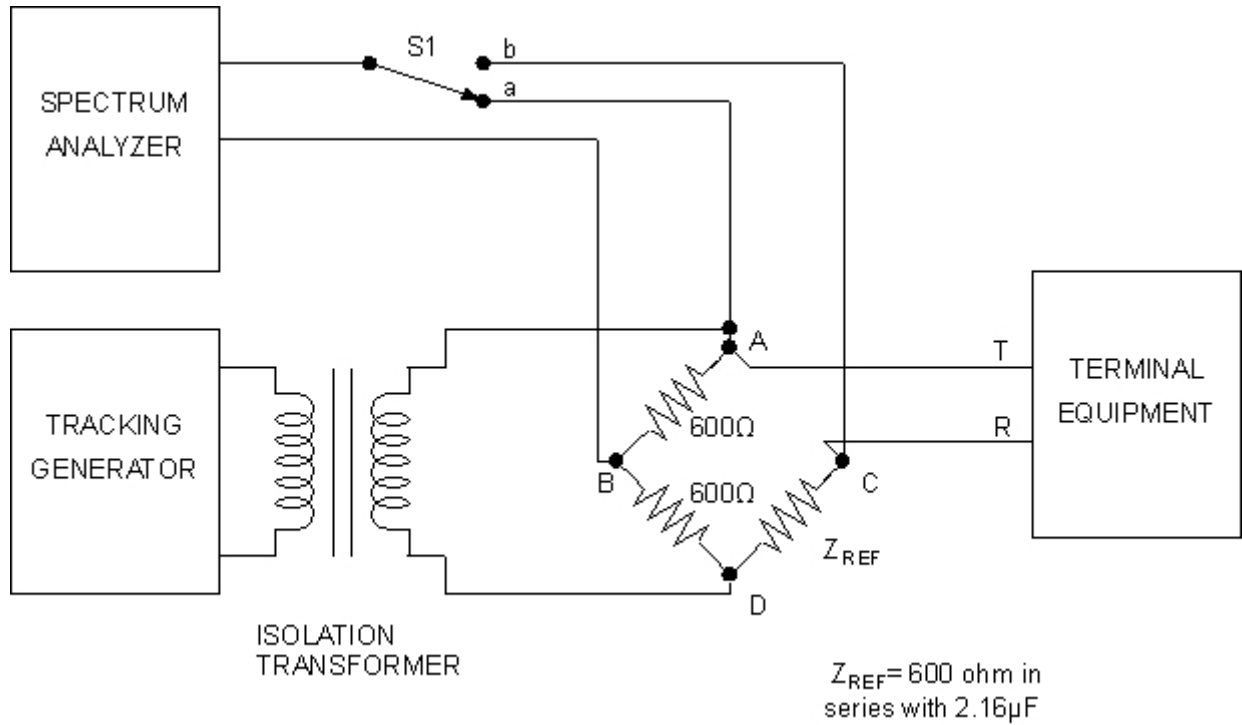

Figure 3.8(a): Return Loss, 2-Wire, T&R

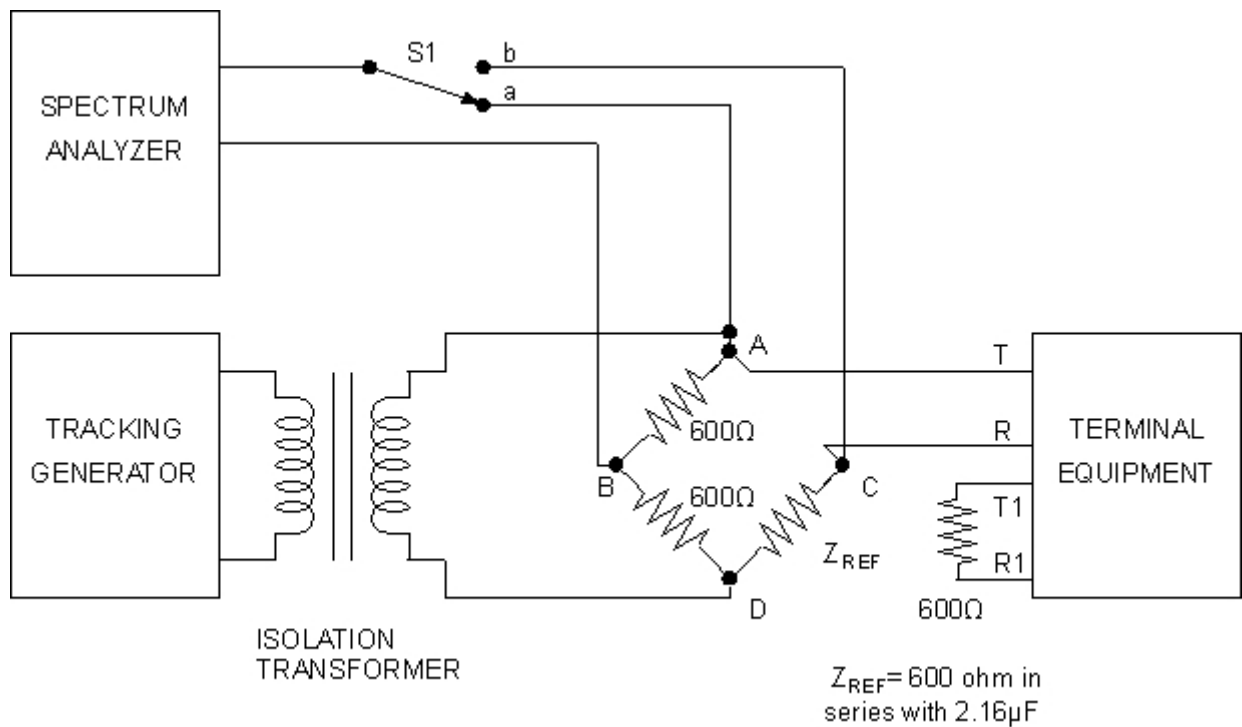

Figure 3.8(b): Return Loss, 4-Wire, T&R

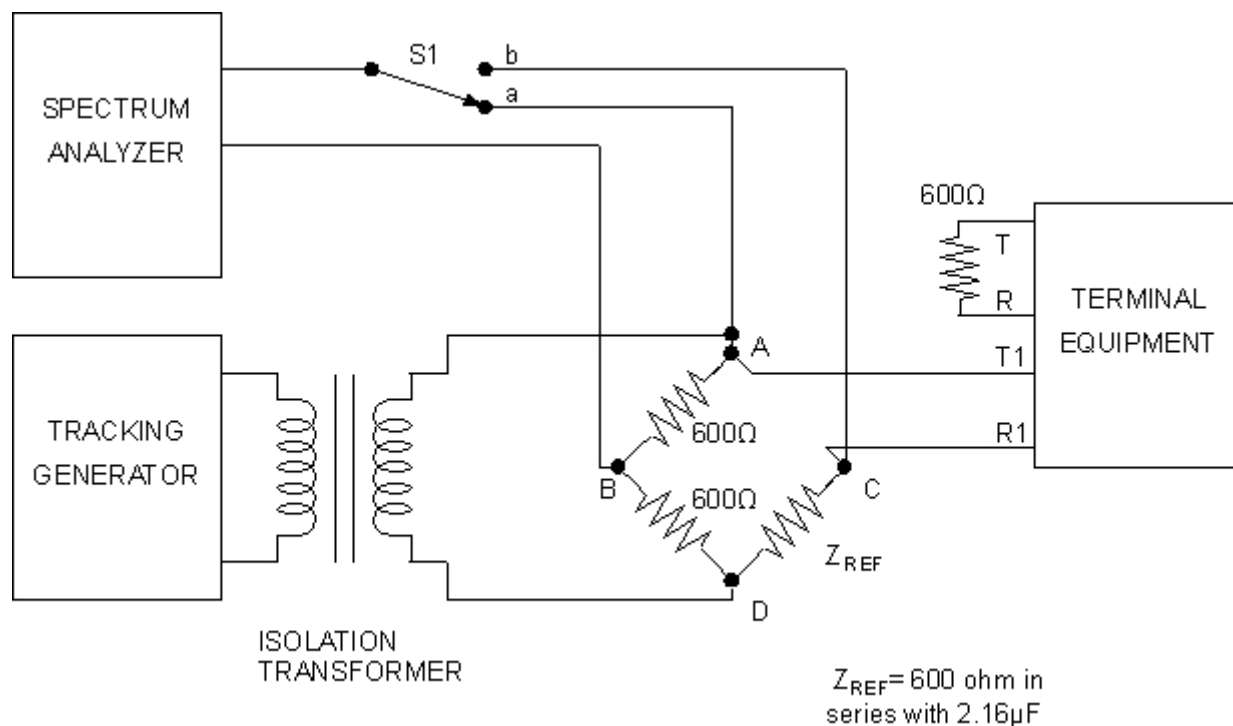

Figure 3.8(c): Return Loss, 4-Wire, T1&R1

3.8.1.2 To Measure Transducer Loss:

- (1) Adjust the tracking generator output level to -10.0 dBV into a 600 ohm load, measured at 1004 Hz. Sweep the band from 200 Hz to 3200 Hz with the spectrum analyzer measuring the level in dBV. This is the reference level measurement.
- (2) Connect the TE to the test circuit of Figure 3.8(d).
- (3) Without adjusting the tracking level generator level, sweep the same frequency band as used in step (1), with the spectrum analyzer measuring the level in dBV.
- (4) The difference, in dB, between the reference level measured in step (1) and the level measured in step (3) is the forward transducer loss of the TE port at any given frequency.
- (5) Connect the TE to the test circuit of Figure 3.8(e).
- (6) Repeat steps (3) and (4).

Note: The transducer loss measured in this case is the reverse transducer loss.

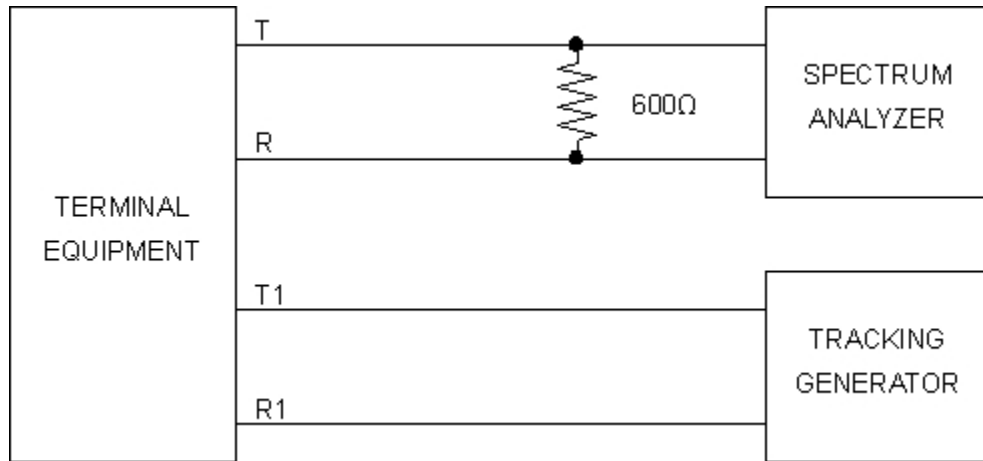

Figure 3.8(d): Transducer Loss, Forward

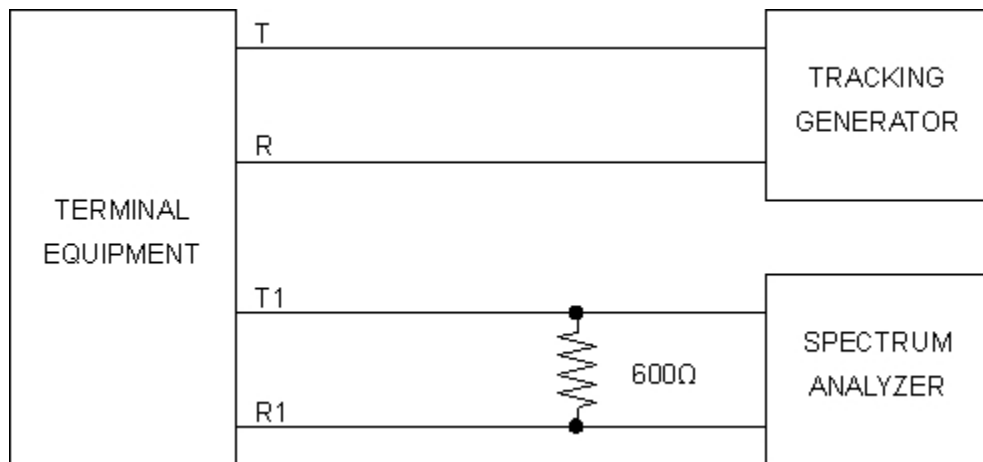

Figure 3.8(e): Transducer Loss, Reverse

3.9 Automatic Dialling and Automatic Redialling

3.9.1 Requirements

Note: Emergency alarm diallers and diallers under external computer control are exempt from these requirements.

- (1) Automatic dialling to any individual number is limited to 2 successive attempts. Automatic dialling equipment which employs means for detecting both busy and reorder signals shall be permitted an additional 13 attempts if a busy or reorder signal is encountered on each attempt. The dialler shall be unable to re-attempt a call to the same number for at least 60 minutes following either the second or fifteenth successive attempt, whichever applies, unless the dialler is reactivated by either manual or external means. This rule does not apply to manually activated diallers which dial a number once, following each activation.
- (2) If means are employed for detecting both busy and reorder signals, the automatic dialling equipment shall return to its on-hook state within 15 seconds after detection of a busy or reorder signal.
- (3) If the called party does not answer, the automatic dialler shall return to the on-hook state within 60 seconds of completion of dialling.
- (4) If the called party answers and the calling equipment does not detect a compatible TE at the called end, then the automatic dialling equipment shall be limited to one additional call which is answered. The automatic dialling equipment shall comply with (1), (2), and (3) for additional call attempts that are not answered.
- (5) Sequential diallers shall dial only once to any individual number before proceeding to dial another number.
- (6) Network addressing signals shall be transmitted no earlier than:
 - (a) 70 ms after receipt of dial tone at the network demarcation point; or
 - (b) 600 ms after automatically going off-hook (for single line equipment that does not use dial tone detectors); or
 - (c) 70 ms after receipt of CO ground-start at the network demarcation point.

3.9.2 Method of Measurement

- (1) Consult the TE manual to determine if the equipment is capable of detecting call progress tones (i.e. dial tone, busy tone and any reorder tone).
- (2) Connect the TE as shown in Figure 3.9 and condition it to automatically dial a pre-programmed number. Count the number of times that the TE will dial the same number. Record the reading.
- (3) Set the storage scope to trigger when the TE goes off-hook. Upon the application of a busy tone, or a recorder tone, use the storage scope to observe if the TE goes back to the on-hook state in less than 15 seconds. Record the reading.
- (4) Apply a dial tone to the TE when it goes off-hook, prior to the device automatically dialling the pre-programmed number. Using the storage scope, record the time from the beginning of dial tone to start of dialling. Record the reading.

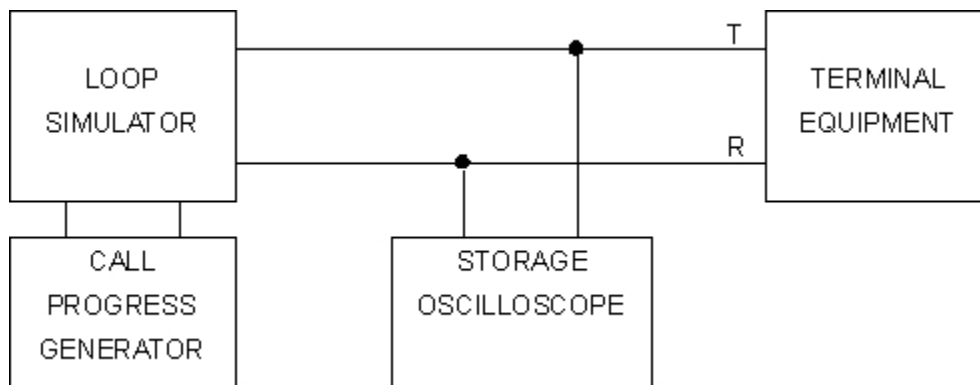

Figure 3.9: Automatic Dialling and Redialling

3.10 Stuttered Dial Tone Detection

Stuttered dial tone detection equipment places the loop in the off-hook state to check for the presence of stuttered dial tone.

3.10.1 Requirements

Terminal equipment that automatically goes off-hook for the purpose of checking for stutter dial tone shall be acceptable for connection to the telephone network provided that it meets all of the applicable requirements of this part, as well as the following requirements:

- (1) The equipment shall not perform periodic testing for stuttered dial tone.
- (2) The equipment shall make a stuttered dial tone check no more than once after a completed calling event, and shall begin the check no earlier than 4 seconds after the subscriber hangs up.
- (3) The equipment shall not make a check more than once after an unanswered incoming calling event.
- (4) The equipment shall not perform a check after an unanswered incoming call event if the message waiting indicator is already lit or on.
- (5) The equipment shall operate in the off-hook mode for no more than 2.1 seconds when making checks for stuttered dial tone. The measurement of the interval shall begin when dial tone is applied. The equipment should abandon the check for stuttered dial tone if dial tone is not applied within 3 seconds.
- (6) The equipment shall synchronize checks when multiple stutter dial tone detectors and visual message signalling indicators are connected to the same network interface, so that only one check is made per calling event.
- (7) The equipment shall not block dial tone when a calling event is initiated during a check for stuttered dial tone.

3.10.2 Demonstration of Compliance

The applicant shall present an attestation which states that the equipment meets requirements (1), (6) and (7) of Section 3.10.1. Compliance with requirements (2), (3), (4) and (5) shall be demonstrated in accordance with the method of measurement described in Section 3.10.3.

3.10.3 Method of Measurement

- (1) Connect the TE to the test circuit of Figure 3.10.
- (2) Simulate the completion of a calling event by means of the host or ancillary telephone set. Monitor and record the number of stuttered dial tone checks that occur and when they occur.
- (3) By means of the loop simulator and a ringing generator, simulate an unanswered incoming calling event. Monitor and record the number of stuttered dial tone checks that occur and when they occur. If the device has a visual message indicator, set the TE so that the indicator is lit. Simulate an unanswered incoming calling event. Monitor and record the number of stuttered dial tone checks that occur and when they occur.
- (4) Cause the TE to perform a stuttered dial tone check as in step (3) above. When the device goes off-hook, apply dial tone within 3 seconds. Measure the amount of time from the initial application of the dial tone to when the device goes back on-hook.
- (5) Cause the TE to perform a stuttered dial tone check as in step (3) above. When the device goes off-hook, do not apply dial tone within the first 3 seconds. Monitor and record when the TE goes back on-hook.

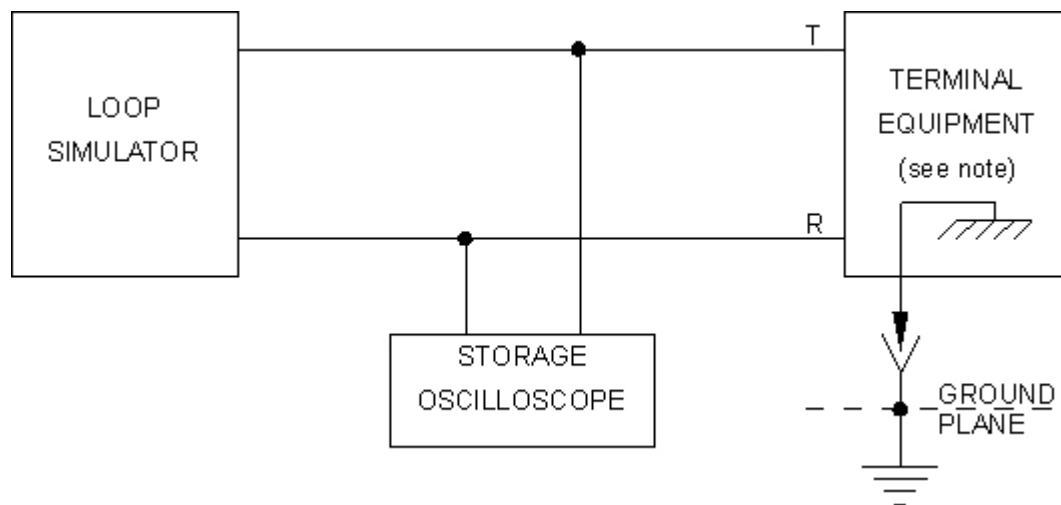

Figure 3.10: Stuttered Dial Tone Detector Timing Measurement Circuit

Note: In this method of measurement, it is assumed that the stuttered dial tone detector is part of a host message waiting telephone set. If the detector is a standalone device, a telephone set may need to be connected in parallel with the detector in order to achieve the test modes described in steps (2) and (3) of Section 3.10.3.

3.11 Manual Programming of Memory Dialling Numbers

3.11.1 Requirements

Terminal equipment that the user places in the off-hook state for the purpose of manually placing telephone numbers in internal memory for subsequent automatic or repertory dialling, shall be acceptable for connection to the telephone network provided it meets all other applicable requirements. Such equipment shall be able to program memory dialling in the off-hook state without providing actual network address signalling (e.g. DTMF or pulse dialling).

3.11.2 Method of Measurement

- (1) Examine the customer instructions for the TE and determine if it provides the capability to program internal memory for automatic or repertory dialling.
- (2) Set the TE to the appropriate dial method, tone dialling or pulse dialling, and connect to the circuit in Figure 3.11.
- (3) Place the TE off-hook and perform the recommended programming sequence.

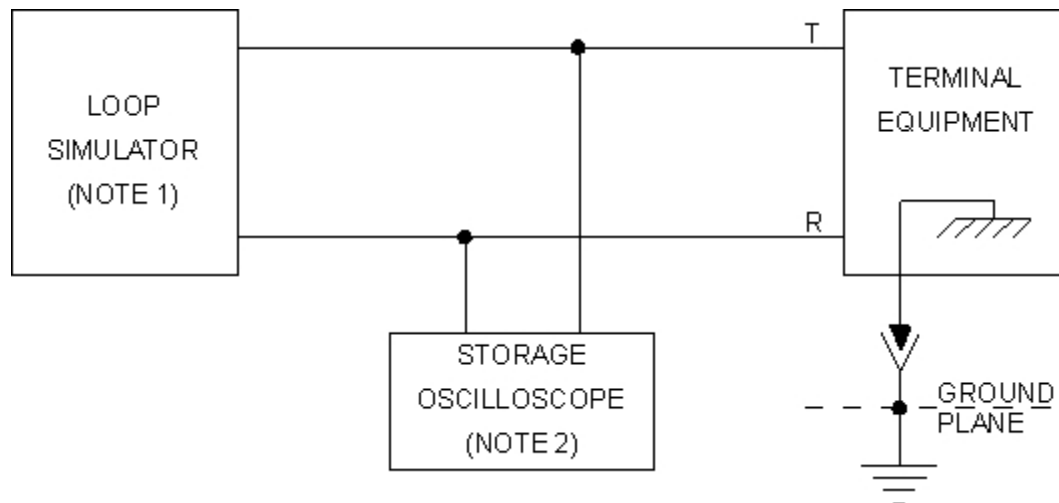

Figure 3.11: Manual Programming of Repertory Dialling Numbers

Notes:

- (1) Select the appropriate loop simulator for the interface of the TE. Refer to the figures of Section 4.
- (2) The oscilloscope should provide a balanced input.

4.0 Special Test Circuits

The special test circuits required to perform the tests described in Section 3.0 are shown in schematic form in this section.

4.1 Loop Simulator for Loop-start and Ground-start Circuits

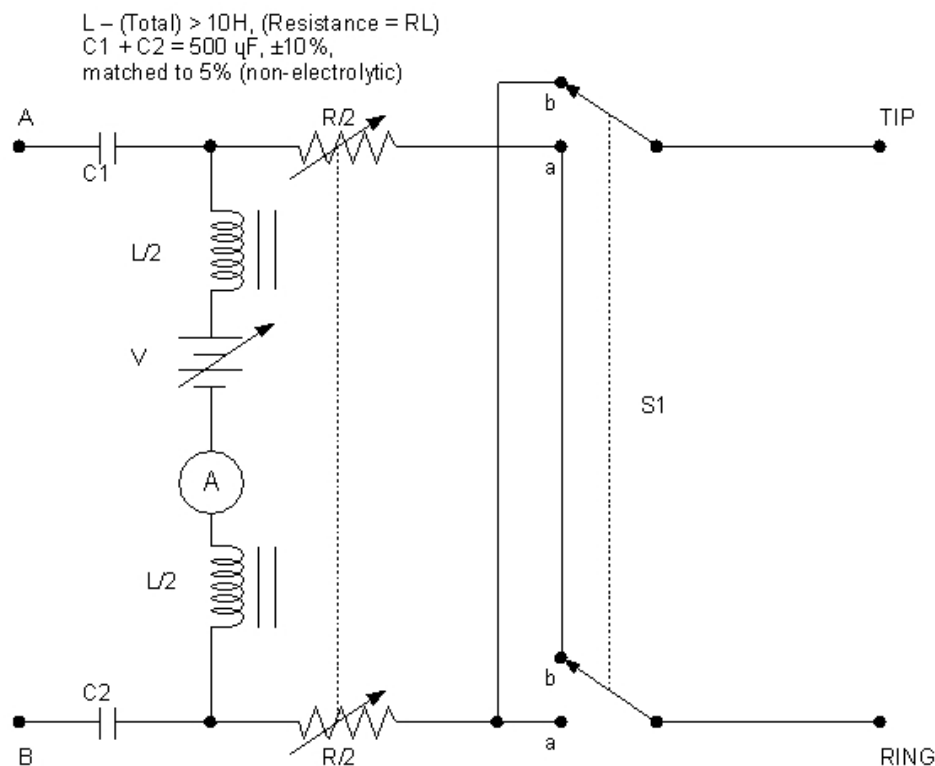

Figure 4.1: Loop Simulator for Loop-start and Ground-start Circuits

Condition	V, volts	Switch Position for Test	R + R_L
1	42.5 to 52.5	Both	Continuously variable over 400 to 1740 Ω
2	105	b	2000 Ω

Notes:

- (1) Means shall be used to generate, at the point of tip and ring connections to the TE protective circuitry, the parameters of DC line current and AC impedance which are generated by the illustrative circuits described above (as appropriate for the equipment under test).

- (2) In performing the longitudinal balance (Section 3.6), the use of the “DC portion of the loop simulator circuit” is specified.

4.2 Loop Simulator for Reverse Battery Circuits

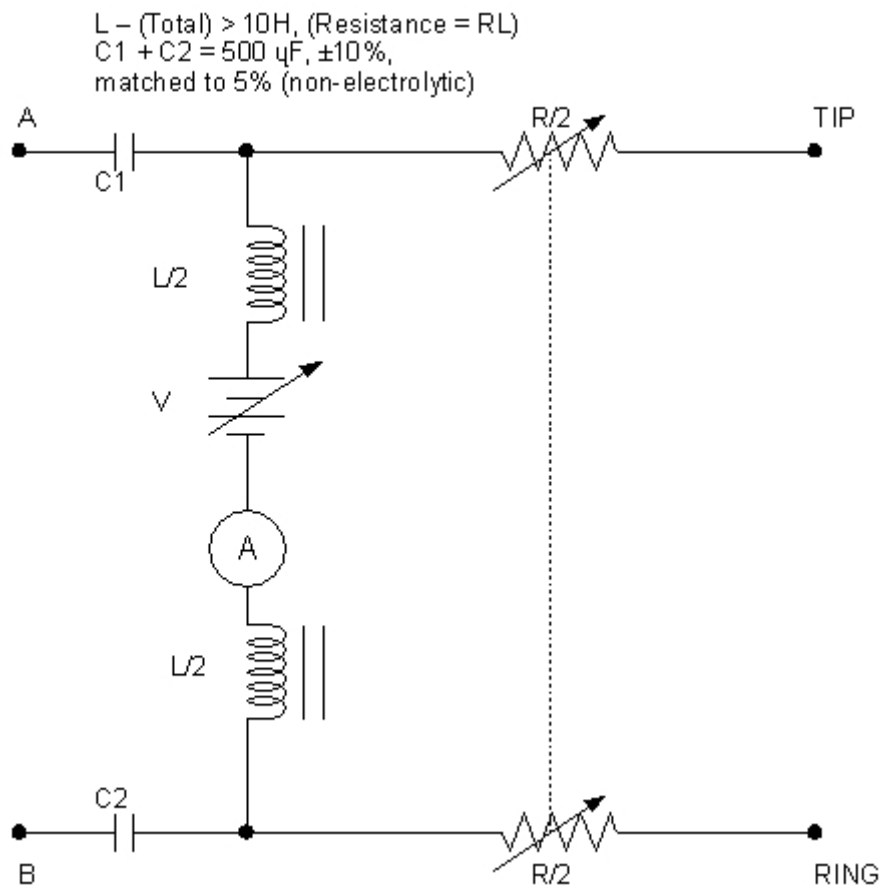

Figure 4.2: Loop Simulator for Reverse Battery Circuits

$R + R_L =$ Continuously variable over 400 to 2450 Ω

Notes:

- (1) Means shall be used to generate, at the point of tip and ring connections to the TE protective circuitry, the parameters of DC line current and AC impedance which are generated by the illustrative circuits described above (as appropriate for the equipment under test).
- (2) In performing the longitudinal balance (Section 3.6), the use of the “DC portion of the loop simulator circuit” is specified. In such cases, components C1 and C2 shall be removed.

4.3 Loop Simulator for 4-Wire Loop/Ground-start Circuits

S1 = POLARITY SWITCH
 L1 = L2 = L3 = L4 = > 5H, (Resistance = RL1, RL2, RL3, RL4)
 R1 = R3 = 600ohms, ±1%
 C1 + C2 = 500 µF, ±10%, matched to 5% (non-electrolytic)

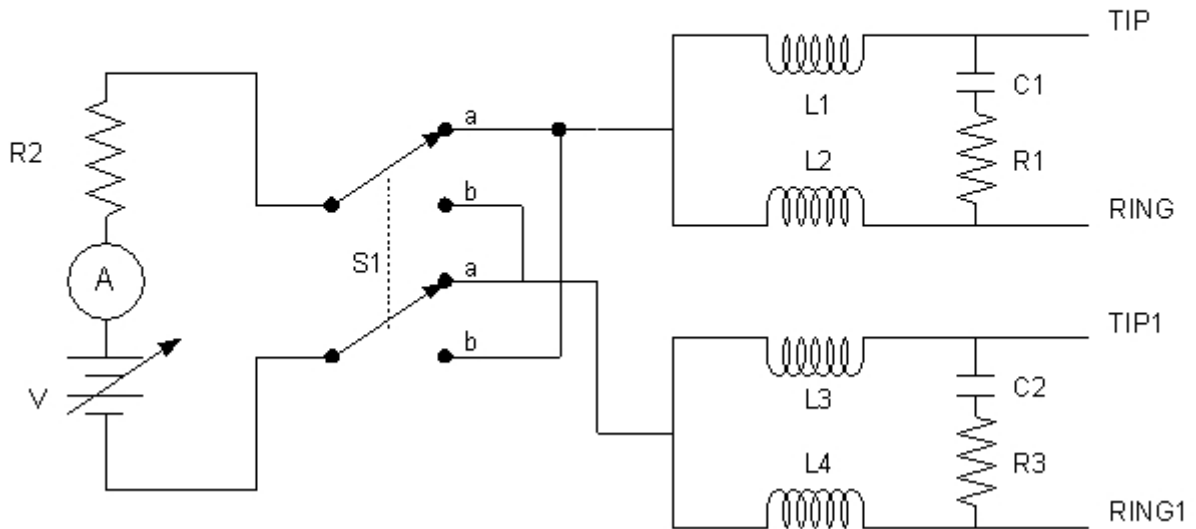

Figure 4.3: Loop Simulator for 4-Wire Loop/Ground-start Circuits

Condition	V, volts	Switch Position for Test	R2 + RL
1	42.5 to 52.5	Both	Continuously variable over 400 to 2450 Ω
2	105	b	1740 Ω

4.4 Loop Simulator for 4-Wire Reverse Battery Circuits

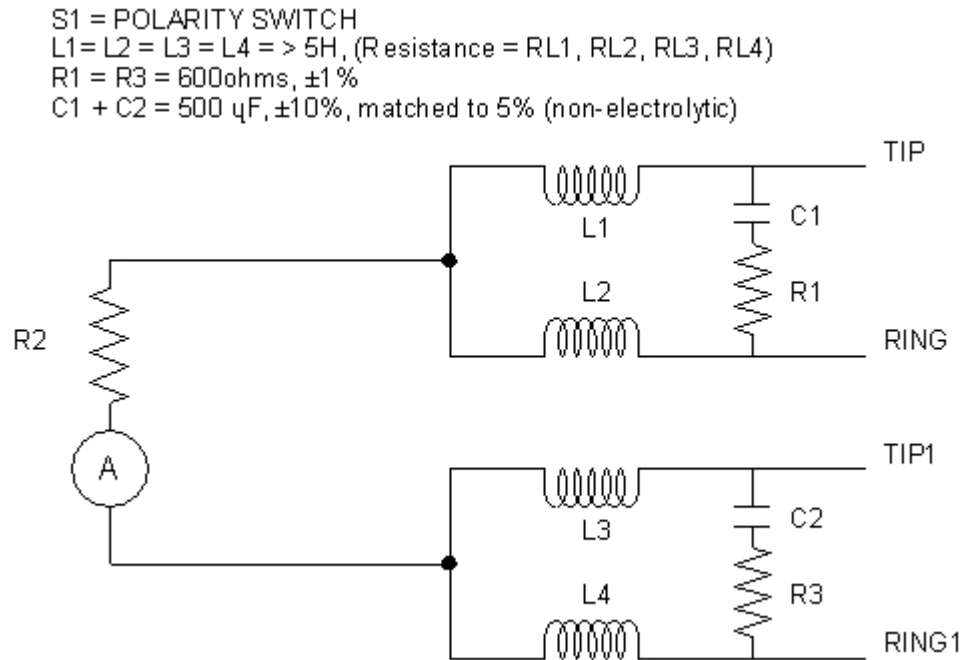

Figure 4.4: Loop Simulator for 4-Wire Reverse Battery Circuits

$R2 + RL =$ Continuously variable over 400 to 2450 Ω

4.5 Off-premises Loop Simulator

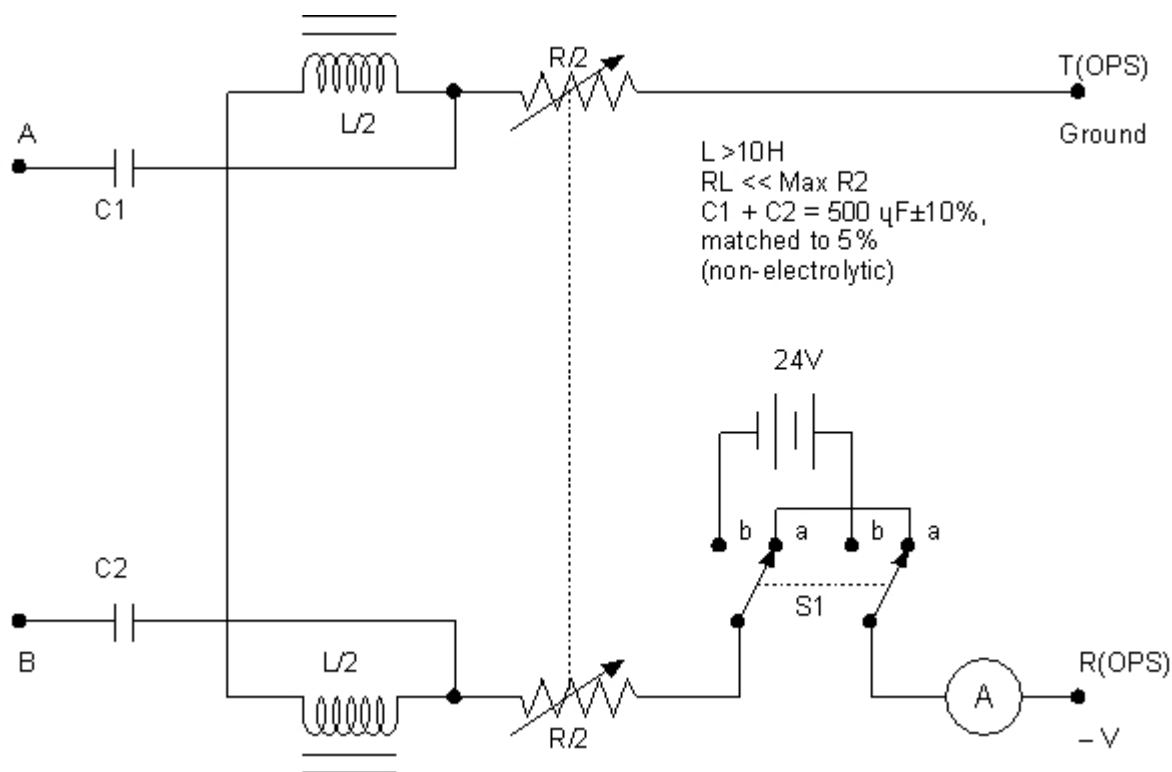

Figure 4.5: Off-premises Loop Simulator

		R + RL Continuously Variable over the Following Range		
Condition	Switch Position for Test	Class A	Class B	Class C
1	a	RL to 200 Ω	RL to 800 Ω	RL to 1800 Ω
2	b	Not Applicable	200 to 2300 Ω	900 to 3300 Ω

The minimum DC current present for all resistance ranges of conditions 1 and 2 shall be 16 mA.

Notes: (1) Means shall be used to generate, at the point of tip (T OPS) and ring (R OPS) connections to the PBX, the range of the resistance and impedance which are employed by the illustrative circuit depicted above.

(2) For the longitudinal balance (Section 3.6), the use of the “DC portion of the line simulator” is specified. In such cases, components C1 and C2 shall be removed.

4.6 Alternative Off-hook Termination

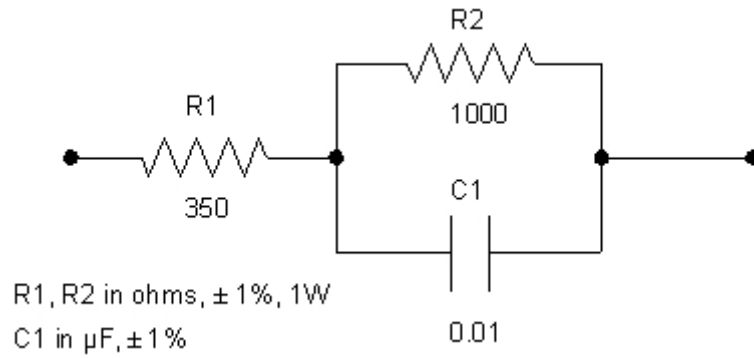

Note: This alternative termination is used to replace 600 ohms.

Figure 4.6: Alternative Off-hook Termination

4.7 E&M Signalling

4.7.1 TE on Side "A"

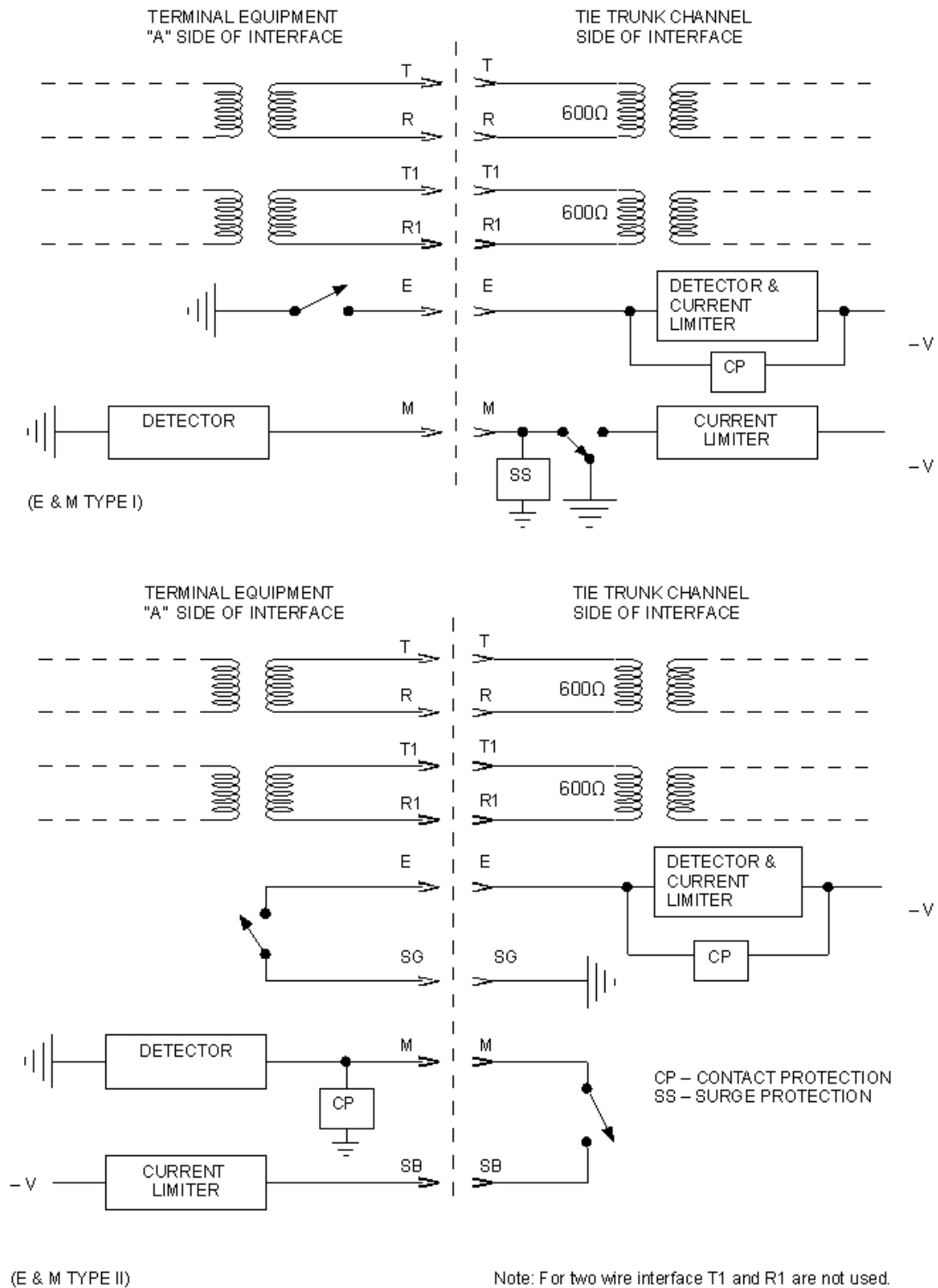
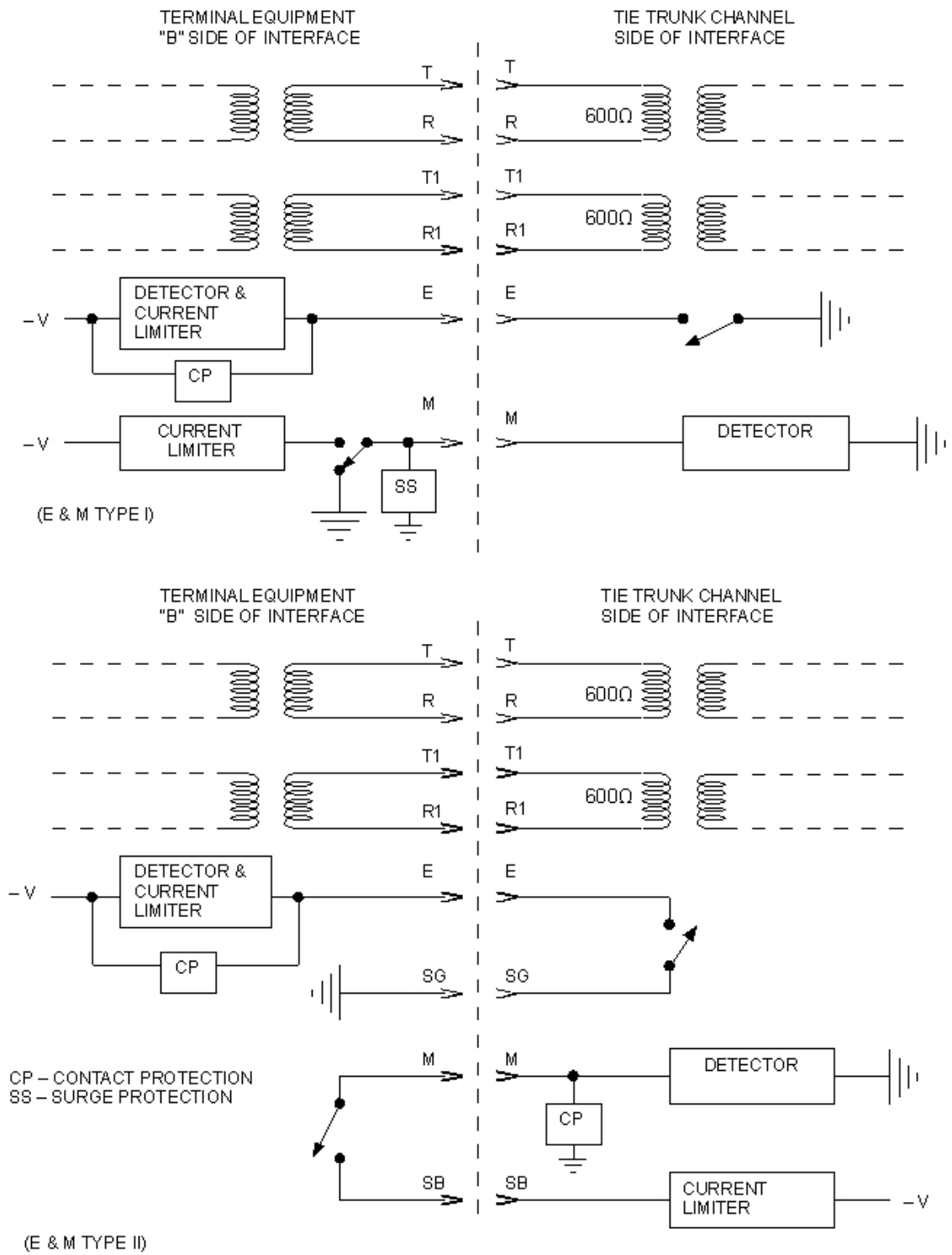

Figure 4.7(a): E & M Types I & II Signalling (TE Originates on M Lead)

4.7.2 TE on Side “B”



Note: For two wire interface T1 and R1 are not used.

Figure 4.7(b): E & M Types I & II Signalling (TE Originates on E Lead)

4.8 Reference Information

4.8.1 Reverse Battery Trunk Interface

(See also Section 3.5.4, Answer Supervision.)

DID TE interface functions are interpreted as follows:

Table 4.8 - DID TE Interface Functions

	Tones	Answer Supervision			Failure Mode Supervision
		Reorder 120 IPM	Required	Not Required	
TE Response/Condition for Incoming Calls	Busy 60 IPM				Reverse Battery or Control Circuit Interface
If the station answers			X		
If the call is answered by an attendant or recorded announcement or other means			X		
If the number is busy	x			X	
If all transmission paths in the TE are busy		X		X	
If the TE returns ring back tone to the caller				X	
If all incoming trunks to the TE are busy	N/A	The network will indicate all-trunks-busy to the caller N/A.			N/A
If the TE is out of service due to: maintenance, power failure, power disconnected or other malfunctions or conditions		The network will indicate all-trunks-busy to the caller. (See Note 1)			X
If the terminal TE returns dial tone to the caller (see Note 2)			X		

Notes:

- (1) This condition is the result of failure mode supervision from the TE.
- (2) Applicable to a TE that is arranged to return a dial prompt to the calling party for the purpose of accepting further dialled digits that may be used to re-route the incoming call to another destination.

5.0 TE Installation Wiring

Note: This section is for information purposes only and does not form part of the mandatory requirements.

5.1 Scope

This section provides guidelines for the installation and wiring of TE when the installation of such equipment requires inside or in-building wiring that is not an integral part of the equipment as registered. Such installation is required to be done under the supervision of qualified personnel, and should be in accordance with the guidelines of this section to ensure that registration requirements will be met when the TE is connected to the network.

5.2 General

TE is normally connected to inside or in-building wiring and is the responsibility of the customer. TE and the associated installation wiring could, under certain circumstances, become exposed to extraneous voltages, current and surges from the network, and from connections to other equipment. For example, they could be subjected to lightning-induced voltage surges of up to a 1000 V peak. The average rise time of such a surge is 100 μ s. The minimum rise time can be less than 10 μ s.

The TE and associated installation wiring should have sufficiently high impedance between the tip and ring and ground reference to allow the metallic and longitudinal voltages to rise at approximately the same rate as a lightning surge. Also, at times, they may be subjected to voltages and current resulting from contact with commercial power facilities under fault conditions. TE and the associated installation wiring should be capable of safely withstanding these extraneous voltages, currents, and surges. They should be installed in such a manner as to ensure continued compliance with the network protection requirements described in Section 3.0.

5.3 Safety Requirements

The installation of the TE and associated wiring should be in accordance with the most recent version of the *Canadian Electrical Code - Part I* (issued by the Canadian Standards Association) which is responsible for specifying safety requirements for electrical installations.

5.4 Technical Requirements

5.4.1 Demarcation Point

The Demarcation Point as defined in the CRTC Telecom Decision 99-10 is the physical location (“point”) where the wires and facilities on one side of the point are under the responsibility and control of one party, and the wires and facilities on the other side of the point are under the responsibility and control of a different party. For single residences, the Demarcation Point is at the carrier-provided jack which shall be installed at an accessible location mutually agreed upon by the carrier and the customers. For multiple-dwelling units, in-building wiring may be owned by a telecommunications service provider or by the property owner. Installation practices may vary depending on the type of building.

5.4.2 Type of Wiring

Wires, cables and connecting devices used in the installation should be of a type designed for use in telecommunications applications and should be suitable for the location and conditions under which they are used. The published recommendations of the manufacturer of either the wiring or TE should be considered sufficient indication of suitability. Examples of good installation practices may be found in CSA Standards T525, *Residential Wiring for Telecommunications*, and T529, *Telecommunications Cabling Systems in Commercial Buildings*.

5.4.3 Limitations on Wiring

The total loss of the TE and the wiring from the Demarcation Point to the farthest TE should be limited by the following conditions:

(1) TE intended for connection to CO lines:

- (a) added resistance of 50 ohms; and
- (b) transmission loss of 0.5 dB.

(2) TE intended for connection to trunks:

- (a) no added resistance; and
- (b) transmission loss of 2.5 dB.

If the above limits are insufficient to meet the customer's requirements, the customer should contact the service provider to determine jointly whether the particulars of the proposed installation will ensure minimum transmission specifications. In the event that transmission compensation is required, the customer may incur additional charges.

5.4.4 Communications Ground

TE requiring a communication ground apart from the safety (green wire) ground shall, in order to minimize the introduction of noise, have a low-impedance path to the main building ground source, separate from that provided by the carrier for its equipment.

Note: In those locations where the local building ground potential may be expected to rise to hazardous levels relative to a remote ground, due to the proximity of an electric power station or similar installation, engineering coordination with the carrier is required.

5.5 Qualifications of Installation Supervision

The person responsible for the direct supervision of the personnel performing the installation shall have the necessary qualifications outlined in the appropriate documents.